

LEADER

MULTI SDI MONITOR

INSTRUCTION MANUAL

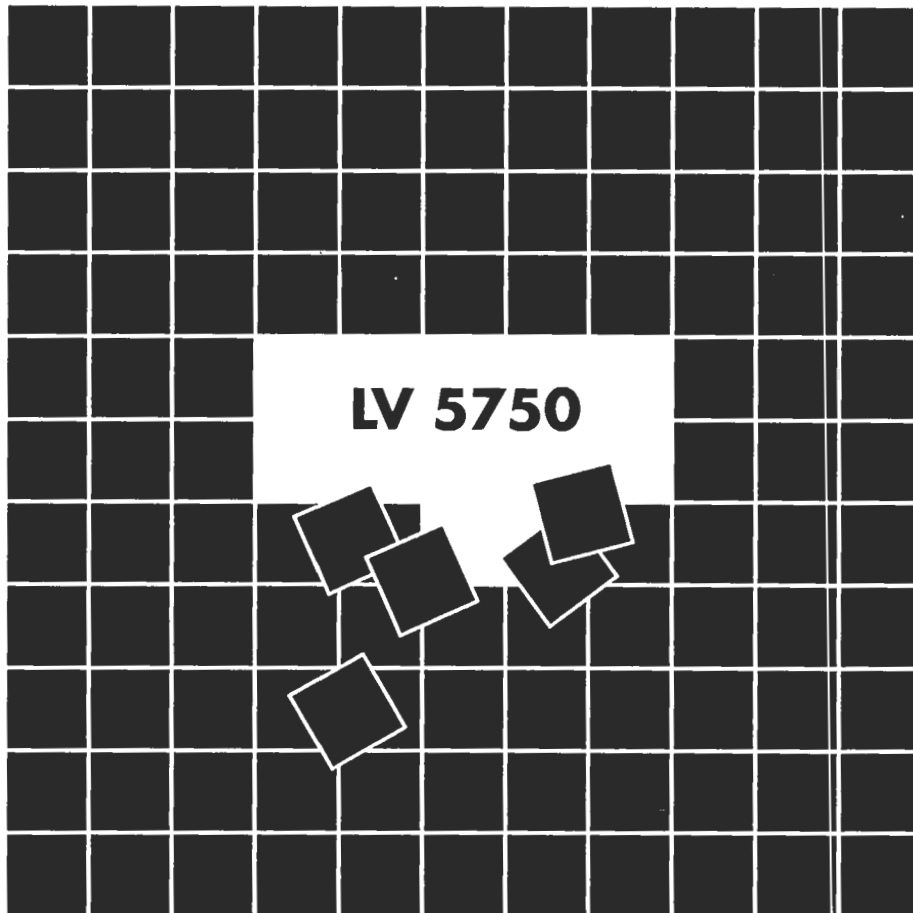

LEADER ELECTRONICS CORP.

TABLE OF CONTENTS

GENERAL SAFETY SUMMARY	I
1. INTRODUCTION	1-1
1.1 Scope of Warranty	1-1
1.2 Operating Precautions	1-1
1.2.1 Power Supply	1-1
1.2.2 Damage Caused by Static Electricity	1-1
1.2.3 Maximum Allowable Input Voltage	1-2
1.2.4 Installation	1-2
1.2.5 Mechanical Shock	1-3
1.2.6 Last Memory and Default Settings	1-3
1.2.7 Fan Stop Message	1-4
1.2.8 LCD Monitor	1-4
1.2.9 Flickering of the LCD	1-4
2. SPECIFICATIONS	2-1
2.1 Description	2-1
2.2 Features	2-1
2.3 Specifications	2-4
2.3.1 Video Formats and Corresponding Standards	2-4
2.3.2 Input/Output Connector	2-4
2.3.3 Display Format	2-6
2.3.4 Waveform Display	2-6
2.3.5 Vectorscope Display	2-7
2.3.6 Picture Display	2-8
2.3.7 Embedded Audio Display	2-8
2.3.8 Status Display	2-8
2.3.9 Screen Capture	2-10
2.3.10 Presets	2-10
2.3.11 Other Display Settings	2-10
2.3.12 General Specifications	2-11
3. PANEL DESCRIPTION	3-1
3.1 Front Panel	3-1
3.2 Rear Panel	3-3
3.3 Top and Bottom Panels	3-5
3.4 Power Supply	3-7
3.5 Power Switch	3-7

3.6	Connections to the Rear Panel Connectors	3-8
3.6.1	SDI INPUT Connector	3-8
3.6.2	EXT REF Connector	3-8
3.6.3	SDI OUTPUT Connector	3-8
3.7	External IF Slot	3-9
3.7.1	Compact Flash Card Unit	3-9
3.7.2	Ethernet Unit	3-9
3.7.3	Remote Control Unit	3-10
4.	MENU STRUCTURE	4-1
4.1	Waveform Display Menu	4-1
4.2	Vectorscope Display Menu	4-3
4.3	Picture Display Menu	4-4
4.4	Audio Display Menu	4-5
4.5	Multi Display Menu	4-7
4.6	Status Display Menu	4-15
4.7	Capture Menu	4-18
4.8	System Menu	4-19
4.9	Preset Menu	4-21
5.	SYSTEM CONFIGURATION BEFORE WAVEFORM MONITORING	5-1
5.1	SDI Input Signal Selection	5-1
5.1.1	SDI Input Signal	5-1
5.1.2	SDI Input Selection	5-1
5.2	External Synchronization Signal Setting	5-2
5.2.1	External Sync Signals	5-2
5.2.2	External Sync Signal Switching	5-3
5.3	System Menu	5-3
5.4	Video Signal Format Setting	5-4
5.4.1	Auto/Manual Selection	5-5
5.4.2	Interlace and Segment Frame Selection	5-5
5.4.3	Scanning Selection	5-6
5.4.4	Field/Frame Frequency Selection	5-6
5.4.5	Format Selection of the Pseudo-Composite Display	5-7
5.5	Screen Display Settings	5-7
5.5.1	Information Display	5-8
5.5.2	Backlight Switching	5-9
5.6	Interface Setting	5-10
5.6.1	Recalling Presets through the REMOTE Connector	5-10
5.6.2	Ethernet Settings	5-10

5.7	Date and Time Settings	5-11
5.8	Shortcut Key Setting	5-12
5.9	Initialization	5-13
6.	VIDEO SIGNAL WAVEFORM DISPLAY	6-1
6.1	Video Signal Waveform Display	6-1
6.2	Display Channel Settings	6-2
6.3	Display Mode Settings	6-2
6.3.1	Overlay Display	6-3
6.3.2	Parade Display	6-3
6.3.3	Timing Display	6-4
6.4	Position Adjustment	6-4
6.5	Brightness Adjustment	6-5
6.5.1	Brightness Adjustment of the Video Signal Waveform	6-5
6.5.2	Scale Brightness Adjustment	6-5
6.6	Gain/Filter Adjustment	6-6
6.6.1	Gain Adjustment	6-6
6.6.2	Gain Selection	6-7
6.6.3	Filter Selection	6-7
6.7	Sweep Settings	6-8
6.7.1	Sweep Selection	6-8
6.7.2	H Sweep Selection	6-8
6.7.3	V Sweep Selection	6-9
6.7.4	Field Selection	6-10
6.7.5	Sweep Magnification	6-10
6.8	Line Selector	6-11
6.8.1	Line Select	6-11
6.8.2	Field Selection	6-11
6.9	Cursor Measurement	6-12
6.9.1	Cursor Display	6-12
6.9.2	X-Axis/Y-Axis Cursor Selection	6-12
6.9.3	Cursor Measurement Unit Selection	6-13
6.9.4	Cursor Movement	6-13
6.9.5	Reference Amplitude Setting	6-14
6.10	Color System Setting	6-14
6.10.1	Color Matrix Conversion	6-15
6.10.2	Y-GBR (R, G, B) Display	6-16
6.10.3	Setup Selection	6-16
6.10.4	Pseudo-Composite Display	6-17

6.11	Scale Settings	6-17
6.11.1	Scale Unit Selection	6-18
6.11.2	Display Selection of the 75 % Color Bar Scale	6-18
6.11.3	Scale Color Selection	6-19
6.12	Blanking Display Settings	6-19
6.13	Mode Key Switching	6-20
7.	VECTORSCOPE DISPLAY	7-1
7.1	Vector Waveform Display	7-1
7.2	Brightness Adjustment	7-2
7.2.1	Brightness Adjustment of Vector Waveforms	7-2
7.2.2	Scale Brightness Adjustment	7-2
7.2.3	IQ Axis Display	7-3
7.2.4	Scale Color Selection	7-3
7.3	Gain Adjustment	7-4
7.3.1	Gain Variable	7-4
7.3.2	Gain Selection	7-5
7.4	Line Selector	7-5
7.4.1	Line Select	7-5
7.4.2	Field Selection	7-5
7.5	Color System Settings	7-6
7.5.1	Composite and Component Display	7-6
7.5.2	Setup Selection	7-7
7.5.3	Color Bar Saturation Selection	7-7
8.	PICTURE DISPLAY	8-1
8.1	Marker Display	8-2
8.1.1	Aspect Marker (4:3)	8-3
8.1.2	Aspect Marker (16:9)	8-4
8.1.3	Safe Action Marker	8-4
8.1.4	Safe Title Marker	8-4
8.1.5	Center Marker	8-4
8.2	Line Select Marker Display	8-5
8.2.1	Line Select Marker Display	8-5
8.2.2	Field Selection of Line Select	8-5
8.3	Picture Size Change	8-6

9. AUDIO DISPLAY	9-1
9.1 Audio Waveform Display Selection	9-2
9.2 Embedded Audio Group Selection	9-3
9.3 Audio Waveform Display Setting	9-3
9.3.1 Brightness Adjustment of Audio Waveforms	9-3
9.3.2 Scale Brightness Adjustment	9-3
9.3.3 Sound and Lissajou Display Format	9-4
9.3.4 Lissajous Display Channel Selection	9-5
9.3.5 Gain Selection	9-5
9.4 Audio Level Meter Setting	9-6
9.4.1 Reference Level Selection	9-6
9.4.2 Dynamic Range Selection	9-6
9.4.3 Scale Selection	9-7
9.4.4 Peak Hold	9-8
9.5 Headphone Output Settings	9-8
9.5.1 Headphone Output ON/OFF	9-8
9.5.2 Headphone Output Volume	9-8
9.5.3 Headphone Output Channel Selection	9-8
9.6 Channel Mapping	9-9
10. MULTI SCREEN DISPLAY	10-1
10.1 Five Multi Screen Modes	10-2
10.2 Display Content Selection in 4 Screen Mode	10-3
10.3 Various Settings on the Multi Screen Display	10-3
10.3.1 Video Signal Waveform Display Setting on the Multi Screen Display ..	10-3
10.3.2 Vectorscope Waveform Display Setting on the Multi Screen Display ..	10-4
10.3.3 Audio Setting on the Multi Screen Display	10-4
10.3.4 Status Setting on the Multi Screen Display	10-4
11. Status Display	11-1
11.1 Status Display Screen	11-2
11.1.1 Status Indication of SDI Signals	11-2
11.1.2 Status Display of Ancillary Data	11-5
11.1.3 Status Display of the Video Signal Level	11-5
11.1.4 Status Display of Embedded Audio	11-6
11.1.5 Other Status Displays	11-7
11.2 Event Log	11-8
11.2.1 Event log list display	11-9
11.2.2 Starting/Stopping the Event Log	11-10
11.2.3 Clearing the Event Log	11-10

11.2.4	Log Operation Mode	11-10
11.2.5	Storage to the Compact Flash Card	11-10
11.2.6	File List of the Compact Flash Card	11-12
11.2.7	Log File Deletion	11-12
11.2.8	Auto Increment of File Mames	11-13
11.3	Data Dump Display	11-13
11.3.1	Data Dump Display Auto Updating and Hold	11-13
11.3.2	Data Dump Display Format Selection	11-14
11.3.3	Auto Search of EAV/SAV	11-15
11.3.4	Line Number and Sample Number Selection	11-15
11.3.5	Storage to the Compact Flash Card	11-15
11.3.6	File List of the Compact Flash Card	11-17
11.3.7	Data Dump File Deletion	11-17
11.4	Status Display of Embedded Audio	11-18
11.4.1	Channel Selection	11-18
11.4.2	Voice Control Packets	11-19
11.4.3	Channel Status	11-19
11.4.4	Channel Status List Display	11-20
11.5	Ancillary Data Display	11-20
11.5.1	EDH Status Display	11-21
11.6	Error Detection Setting	11-22
11.6.1	Error Alarm Setting	11-23
11.6.2	Error Count Rate Setting	11-23
11.6.3	Detection ON/OFF of Errors	11-23
11.7	Detection Value Setting of Errors	11-26
11.7.1	Gamut Error Threshold Level	11-26
11.7.2	Composite Gamut Error Threshold Level	11-27
11.7.3	Detection Value of Equivalent Cable Length Meter Error	11-28
11.8	Error Display Operation	11-29
11.9	Cable Selection of the Cable Length Meter	11-29
11.9.1	HD-SDI Cable Selection	11-29
11.9.2	SD-SDI Cable Selection	11-30
11.10	Error Reset	11-30

12. CAPTURE FUNCTION	12-1
12.1 Screen capture	12-2
12.2 Display Selection	12-2
12.3 Storage to the Compact Flash Card	12-2
12.4 Recalling from the Compact Flash Card	12-5
12.5 File List of the Compact Flash Card	12-5
12.6 Deletion of Capture Files	12-5
12.7 Auto Increment of File Names	12-5
12.8 Storage File Selection	12-5
13. Preset Function	13-1
13.1 Recalling of Settings	13-1
13.2 Registration of Settings	13-1
13.2.1 Comment Entry	13-2
13.2.2 Storing of the Settings	13-3
13.2.3 Deleting of the Settings	13-3
13.2.4 Editing of Presets	13-3
13.3 Copying of All Presets	13-3
13.3.1 Copying from the CF Card to the Internal Memory	13-3
13.3.2 Copying from the Internal Memory to the CF Card	13-4

GENERAL SAFETY SUMMARY

■ To Avoid Personal Injury

It is recommended that only qualified personnel with technical knowledge use this instrument only after reading and fully understanding all functions of the instrument described in this instruction manual.

This instrument is not designed and manufactured for consumers.



If you do not have enough knowledge on electricity, to avoid personal injury and prevent damage to this product, please be sure to use this product only under the supervision of an engineer who has sufficient knowledge about electronics.

■ Precautions on Contents

Should you find the contents in this manual and any of its technical terms confusing, please feel free to contact your local Leader agent.

■ Symbols and Terms

Following terms and symbols indicate necessary warnings and cautions used in this manual and on the product are there for safe operation.

<p><Symbol></p> 	<p>The sections where this symbol is marked in this manual or instrument, if not correctly performed or practiced, could result in personal injury or cause serious danger to the instrument. Misuse could also produce unintentional movement to create an operational impediment on the instrument or other products that might be connected to it.</p> <p>Be sure to refer to the safety precautions in this manual to safely use the part of the instrument where the symbol is marked.</p>
<p><Term></p>  WARNING	<p>Warning statements identify warning conditions that if disregarded or not correctly performed or adhered to, could result in serious personal injury or even loss of life.</p>
<p><Term></p>  CAUTION	<p>Caution statements identify warning conditions if disregarded or not correctly performed or adhered to, could result in personal injury or damage to the instrument.</p>

GENERAL SAFETY SUMMARY

Review the following safety precautions to avoid operator's injury and loss of life and prevent damage and deterioration to this instrument. To avoid potential hazards, use this product as specified.



WARNING

■ Warnings on the Cases and Panels of the Instrument

Operator should not remove any cases or panel for any reasons. If you touch inside the instrument it could result personal shock or fire hazard. Refrain from spilling any liquid on or inserting anything flammables or piece of metal into the ventilation of the instrument. Such actions could cause fire, shock, malfunction and be an accident hazard while the power is on.

■ Warnings Concerning the Power Line

Use a line voltage in the range of 10 VDC to 18 VDC. A line voltage exceeding this range may cause fire.

■ Warning on Installation Environments

● About the Guaranteed Operating Temperature Range

Operate the instrument between the temperature range of 0 to 40 °C. Operating the instrument at higher temperatures could cause a fire hazard.

Rapid changes of temperatures from cold to warm can create internal moisture or condensation and could damage the instrument. If there is a possibility of moisture condensation allow the instrument to sit for 30 minutes without the power on.

● About the Guaranteed Operating Humidity Range

Operating humidity range is $\leq 85\%$ RH.

Do not operate the instrument with wet hands, This could cause a shock and fire hazard.

● About the Operation in the Presence of Gasses

Operating the instrument in and near the presence or storage locations of flammable, explosive gasses or fumes could create an explosion and fire hazard.

Do not operate the instrument anywhere near such environments.

● Avoid Insertions

Do not insert metals or flammable objects or drop liquid on or into the instrument. To do so could cause fire, shock, malfunction and create a dangerous accident hazard.

■ Warning while Operating

While operating the instrument in smoke, fire, or a bad smell, occurs, turn off the instrument at once for it could cause a fire hazard. When such a case occurs, turn off the power switch and pull the plug of the cord from the plug socket. Contact your local Leader agent after confirming there is no fire.

GENERAL SAFETY SUMMARY



CAUTION

■ Warnings Concerning the LCD Panel

Glass is used on the LCD panel. If you break the glass, the fragments may cause injury. Do not apply strong shock to the glass or damage the surface of the glass with sharp metal objects.

■ Caution on Input/Output Terminals

Input Terminals are rated with a maximum input. Do not supply an input over the specified rating in the standard section of the instruction manual. Also, do not supply external power to Output terminal, this could cause the instrument to malfunction.

■ Caution when Not to Using Instrument the for a Long Time

Make sure to disconnect the power cord from the socket or remove a battery from the instrument when you do not use the instrument for a long time.

■ Calibration

This instrument is produced under the strictest quality controls at the factory, but accuracy may gradually deteriorate due to worn components. Therefore, periodic calibration should be performed. When service or calibration is required, contact your local Leader agent.

■ Routine Maintenance

Remove the power cord plug from the socket when cleaning the instrument. Avoid the use of thinner or benzene solvents for cleaning cases, panels and knobs since this might remove the paint or damage plastic surfaces. Wipe cases, panels, and knobs lightly with a soft cloth damped with neutral detergent. Do not allow water, detergent, or other foreign objects to enter the instrument while cleaning. If a liquid or metal object enters the instrument, it can cause electric shock or fire.

Please conform to the above warnings and cautions for safe operation. There are cautions in each area of in this instruction manual, so please conform to each caution. If you have any questions about this manual, please feel free to contact your local Leader agent.

1. INTRODUCTION

Thank you for purchasing Leader's measuring instruments.
Please read this instruction manual carefully to ensure correct and safe operation.
If you have any difficulties or questions on how to use the instrument after you have read this manual, please feel free to contact your local Leader agent.

1.1 Scope of Warranty

This Leader instrument has been manufactured under the strictest quality control guidelines. Leader shall not be obligated to furnish free service during the warranty period under the following conditions.

1. Repair of malfunction or damages resulting from fire, natural calamity, or improper voltage applied by the user.
2. Repair of an instrument that has been improperly repaired, adjusted, or modified by personnel other than a factory-trained Leader representative.
3. Repair of malfunctions or damages resulting from improper use.
4. Repair of malfunctions caused by devices other than this instrument.
5. Repair of malfunctions or damages without the presentation of a proof of purchase or receipt bill for the instrument.

1.2 Operating Precautions

WARNING

1.2.1 Power Supply

The LV 5750 uses a DC power supply. It will not operate on AC power. If you apply AC power by mistake, it may cause a fire or malfunction.

The voltage range of the DC power supply is 10 V to 18 V. Do not apply voltage exceeding this range as it can cause a malfunction or fire.

There are two power supply input connectors, a V-mount adapter, which is assumed for battery use, and an XLR connector.

If you apply power to both connectors simultaneously, the LV 5750 will operate on the power supplied by the XLR connector. However, please avoid switching the power supply during operation as it may cause erroneous operation. If you need to switch the power supply, turn OFF the power to do so.

CAUTION

1.2.2 Damage Caused by Static Electricity

Electronic parts are susceptible to damage from electrostatic discharge (ESD). The core wire of the coaxial cable may be charged with static electricity. If you are connecting a coaxial cable that is not connected on either end to an input/output connector of the instrument, short the cable's core wire and external conductor beforehand.

⚠ CAUTION

1.2.3 Maximum Allowable Input Voltage

The maximum allowable input voltage to the input connectors is shown in the table below.

Do not apply excessive voltage to prevent damage to the instrument.

Refer to Installation Category I (IEC 1010-1, Annex J).

Input Connector	Maximum Allowable Input Voltage
SDI INPUT	± 2 V (DC + peak AC)
EXT REF	± 5 V (DC + peak AC)
REMOTE	Input TTL level Within +5 V to -0.3 V

The maximum input voltage of " ± 5 V (DC + peak AC)" is as shown in Figure 1.1.

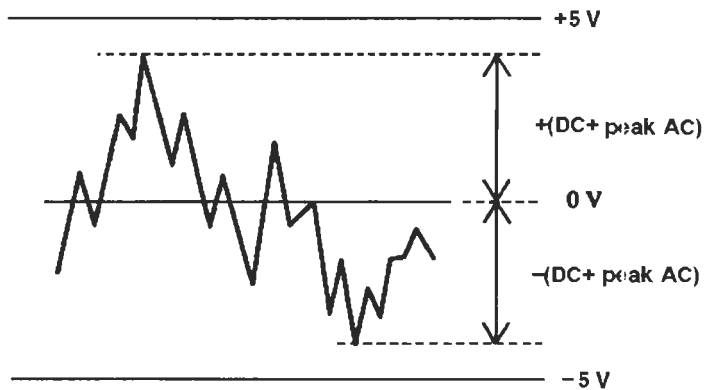

Figure 1.1 DC + Peak AC

⚠ CAUTION

1.2.4 Installation

Do not use the instrument in the following environments.

- High temperature environments
Do not place the instrument under direct sunlight or near a heater (e.g., stove). Avoid using the instrument in a way that leads to drastic changes in temperature such as moving the instrument from a cold environment to a hot environment; this may cause condensation.
Operating temperature range: 0 to 40 °C
- High humidity environments
Do not place the instrument in a high humidity environment (e.g., bathroom, near a humidifier).
Operating humidity range: ≤ 85 % RH (without condensation)
- Dusty environments
- Strong magnetic fields
Do not place the instrument near a strong magnetic source (e.g., high-power transformer).

⚠ CAUTION

1.2.5 Mechanical Shock

Do not apply strong shock to the instrument. A strong shock can break precision parts of the instrument such as the internal crystal oscillator or LCD and can cause a malfunction.

If the LCD breaks, glass fragments may cause injury.

1.2.6 Last Memory and Default Settings

The last memory function retains the front panel settings that exist immediately before the power is turned off. When the power is turned on again, the front panel settings are set to the previous settings.

If the battery runs out or the power supply is cut off with the power turned ON, the LV 5750 will be ON the next time the power is supplied.

However, if the backup battery for the last memory function runs out, a message as shown in the figure below appears when the LV 5750 starts. If this happens, contact your local Leader agent and request repairs.

If you press the WFM key, the LV 5750 will operate using initial settings.

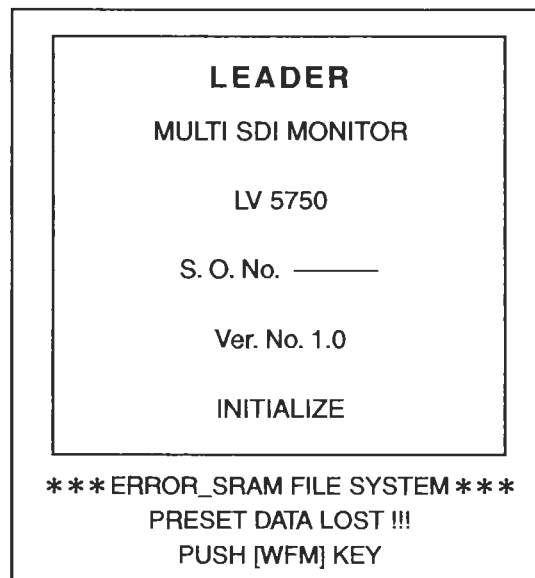

Figure 1.2 Message that appears when the backup battery runs out

1.2.7 Fan Stop Message

The LV 5750 has a fan near the rear panel for internal cooling.

If the fan stops due to a malfunction, the following message blinks at 1-second intervals. If this happens, turn OFF the power immediately, contact your local Leader agent, and request repairs.

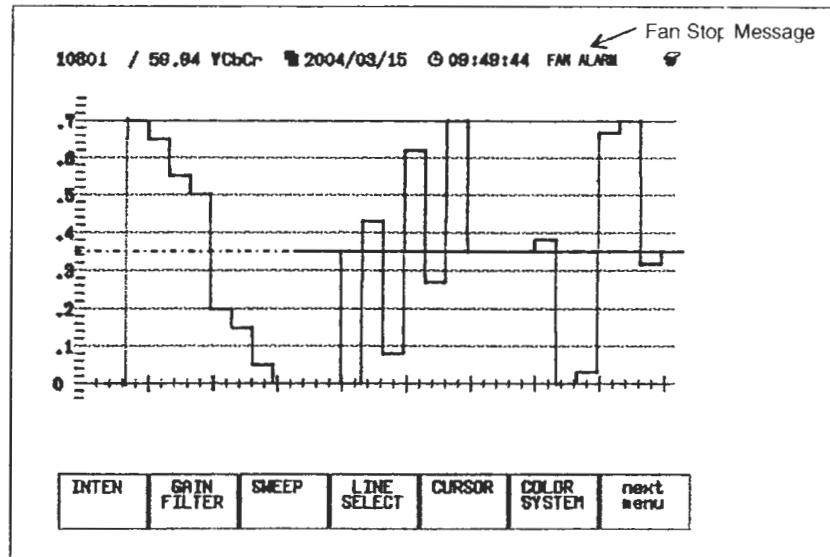

Figure 1.3 Fan Stop Message

1.2.8 LCD Monitor

There may be pixels on the LCD monitor that do not turn ON or those that remain ON at all times. This is not a malfunction.

1.2.9 Flickering of the LCD

The LCD on the LV 5750 supports many types of video signals. The LCD displays the input SDI signal asynchronously and may flicker on the waveform display or picture display. The LV 5750 stores the input SDI signal once to the frame memory, and then reads the memory using the LCD sync signal, which is asynchronous to the input SDI signal. Therefore, flickers may occur due to frame skip, which skips over certain frame memories, or frame repeat, which reads certain frame memories twice.

2. SPECIFICATIONS

2.1 Description

The LV 5750 is a waveform monitor for HD-SDI and SD-SDI signals. The LV 5750 employ color TFT LCD screen.

The functions of waveform monitors, vectorscopes, audio lissajous, and simple picture monitors are achieved with a single unit.

Complete digital processing of SDI signals enables highly accurate measurements. In addition, extensive error detection functions and analysis functions are provided which allows the LV 5750 to be used as SDI signal monitors.

2.2 Features

- **Two serial digital input systems**

The SDI input connector on the LV 5750 supports free rates. Thus, either HD-SDI or SD-SDI signals can be applied to the same connector. You can select auto or manual setting for the input signal format.

- **SDI Output**

Equipped with an active output connector that reclock the input signal.

- **Display**

Employs a color TFT LCD monitor with XGA resolution (1,024 x 768).

The LCD monitor can show various displays such as waveform display, vectorscope display, picture display, audio display, and status display. These displays can also be placed side by side on a single screen (multi display).

- **Waveform display**

Displays waveforms of serial digital signals side by side or overlaid.

The amplitude can be set to variable or expanded up to 5 times.

The time axis can be expanded 10, 20 or 40 times.

Enables level measurements and time measurements using cursors.

In addition, a composite signal conversion function that artificially converts component signals into composite signals such as NTSC or PAL is provided.

This function allows the level of component signals to be managed in a similar fashion as conventional analog signals.

- **Vectorscope function**

Displays chrominance difference signal in vector format.

The amplitude can be set to variable, IQ-MAG, or expanded up to 5 times.

You can turn on/off the IQ axis display, which is convenient for monitoring signals.

- **Picture display**

Displays SDI signals on a simple color picture display.

- Line selector
Enables the selection and display of arbitrary video signal lines.
Can be used on the waveform display, vectorscope display, picture display, and data dump display.
- Embedded audio signal display function
Separates the embedded audio signal from the serial digital signal and shows lissajous display, sound image, and level meter display.
Level display shows eight channels, and the range and response can be changed.
* The audio quantization precision of SD-SDI is 20 bits.
- Screen capture
Enables the displayed screen to be captured to the internal memory or *¹ compact flash memory card. The BMP data of the screen image can be retrieved into a PC via the network using *² FTP.
When the internal memory or *¹ compact flash memory card is used, the captured screen and the signals that are input sequentially can be superimposed on the screen.
- **Extensive Analysis Functions**
 - Various types of error detection
Detects *³ CRC errors, *³ EDH errors, *³ BCH errors, checksum errors. Error detection is useful in the monitoring of SDI signals.
 - Event log function of SDI signals
Logs detected errors and events and stores the log list to the *¹ compact flash memory card. The log can be retrieved as text data into a PC via the network using *² FTP.
 - Digital data dump function
The digital data after parallel conversion can be displayed in hexadecimal or binary notation. This is useful when problems occur or when analyzing various types of data.
The data dump can be stored to a *¹ compact flash memory card. The data dump can be retrieved as text data into a PC via the network using *² FTP.
 - Analysis display
Analyzes and displays voice control packets embedded in the SDI signal, the channels status, EDH packets, and other packets in the AES/EBU signal.
- **Operation**
 - Remote control
The LV 5750 can be controlled through the panel and remotely controlled through a computer via the *² Ethernet network. In addition, presets can be recalled using the *⁴ remote connector on the rear panel.

- **Preset function**
Stores up to 30 sets of frequently used panel settings.
You can easily recall stored settings from the panel, *² Ethernet network connector or *⁴ remote connector.
- **External Synchronization**
Allows tri-level sync signals or B. B signals of NTSC and PAL to be input.
- **Illumination of all key LEDs**
You can turn on all the key LEDs. This is useful when operating the LV 5750 in a very dark place.
- **Power supply**
A V-mount battery adapter is available on the rear panel of the LV 5750 which enables the use of batteries used on video cameras and other equipment.
An XLR DC input connector is also available for operation on a 12-VDC power supply.
- **Tripod attachment**
A screw hole for attaching a camera tripod is provided on the bottom panel of the LV 5750. The LV 5750 can be mounted on a tripod.
- **Dedicated rack mount adapter (sold separately)**
By using the dedicated rack mount adapter that is sold separately, the LV 5750 can be rack mounted on a rack with short depth.
To rack mount the LV 5750, remove the outer case and use the dedicated rack mount adapter.

- *¹ A compact flash memory card unit that comes standard is required.
In this case, the Ethernet Unit and the Remote Control Unit that are sold separately cannot be used.
- *² An Ethernet Unit sold separately is required.
In this case, the compact flash memory card unit that comes standard and the Remote Control Unit that is sold separately cannot be used.
- *³ CRC error and BCH error detection is used for HD-SDI; EDH error detection is used for SD-SDI.
- *⁴ A Remote Control Unit sold separately is required.
In this case, the compact flash memory card unit that comes standard and the Ethernet Unit that is sold separately cannot be used.

2.3 Specifications

2.3.1 Video Formats and Corresponding Standards

(1) Video Signal Standards

	Format Name	Standard Supported
1	1080i/60	SMPTE 274M,292M
2	1080i/59.94	
3	1080i/50	
4	1080p/30	
5	1080p/29.97	
6	1080p/25	
7	1080p/24	
8	1080p/23.98	
9	1080PsF/30	SMPTE RP211,292M
10	1080PsF/29.97	
11	1080PsF/25	
12	1080PsF/24	
13	1080PsF/23.98	
14	720p/60	SMPTE 296M
15	720p/59.94	
16	525i/59.94	SMPTE 259M
17	625i/50	

(2) Other Standards

- Ancillary data standard
SMPTE 291M
- Embedded audio standard
 - HD-SDI SMPTE 299M
 - SD-SDI SMPTE 272M

(3) Format Setting

- SDI Signal Select auto setting or manual setting
- Sampling Frequency 74.25 MHz (HDTV), 74.25/1.001 MHz (HDTV), 13.5 MHz (SDTV)
- External Synchronization Auto setting by HDTV tri-level sync signal or SDTV black burst.

2.3.2 Input/Output Connector

(1) SDI Input

- Input Connector BNC connector 2 systems A and B
- Input Impedance 75 Ω
- Input Return Loss ≥ 15 dB 5 MHz to serial clock frequency
- Maximum input voltage ± 2 V (DC + AC peak)

(2) External Reference Input

Input Signal	Tri-level sync signal or NTSC/PAL black burst	
Input Connector	BNC connector	1 system 2 connectors
Input Impedance	15 k Ω	Passive Loop-through
Input Return Loss	≥ 30 dB	
Maximum input voltage	± 5 V (DC + AC peak)	

* If the video signal waveform is displayed using an external sync signal as reference, the waveform phase of 1 clock before and after the video signal clock is indefinite.

(3) SDI Output

Output Connector	BNC connector	1 connector
	Reclocks and outputs the selected SDI input signal	
Output Impedance	75 Ω	
Output Voltage	800 mVp-p ± 10 %	
Output Return Loss	≥ 15 dB	5 MHz to serial clock frequency

(4) Headphone Output

Output Signal	Separates and outputs the embedded audio signal in the SDI signal	
Sampling Frequency	Only supports 48 kHz (must be synchronized to the video signal)	
Output Connector	Miniature jack	1 connector (stereo)
Volume Adjustment	Set from the menu	
Impedance	32 Ω (16 Ω to 600 Ω)	
Quantization Accuracy	HD-SDI: 24 bits SD-SDI: 20 bits	

(5) IF Slot

Installable Units	Select one unit from the following: Compact Flash Memory Card Unit Remote Control Unit (sold separately) Ethernet Unit (sold separately)
-------------------	---

(6) Compact Flash Memory Card Unit

Function	Saves screen captures, error logs, preset data, and data dumps
----------	--

(7) Remote Control Unit (Sold separately)

Function	Recalling of presets, monitoring of errors	
Control Signal	TTL level (LOW active)	
Control Connector	25-pin D-sub	1 connector (female)

* The compact flash memory card unit that comes standard and the Ethernet Unit that is sold separately cannot be used.

(8) Ethernet Unit (Sold separately)

Function	Remote control from an external computer and monitoring of errors, etc.	
Type	10BASE-T/100BASE-TX Auto switching	
Input/Output connector	RJ-45	1 connector
Standard	Conforms to IEEE802.3	

* The compact flash memory card unit that comes standard and the Remote Control Unit that is sold separately cannot be used.

2.3.3 Display Format

Display Format	XGA	Effective area 1024 x 768 dots
Display	1-screen display Waveform display, vectorscope display, picture display, audio display, and status display	
	2-screen display Waveform display and vectorscope display Waveform display and picture display Waveform display and audio waveform display Waveform display and audio level display	
	4-screen display Select audio waveform display or status display in addition to waveform display, vectorscope display, and picture display.	

2.3.4 Waveform Display

(1) Waveform Operation

Display Mode	Overlay display: Displays component signals overlaid Parade display: Displays component signals side by side Timing display: Displays by calculating Y-C _B and Y-C _R Uses bowtie signals (authorized by Tektronix, Inc.)
EAV-SAV Period	Select show or hide
G, B, R Conversion	Converts Y, C _B , C _R signals into G, B, R and displays the result
Pseudo-Composite Display	Artificially converts component signals into composite signals and displays the result
Channel Assignment	Select GBR order or RGB order during GBR conversion display
Scale	Select V scale or % scale You cannot select scales when pseudo-composite display is selected.
Line Select	Displays the selected line

(2) Vertical Axis		
Gain	Select x1, x5, or variable	
Variable gain	x0.2 to x10.0	
Amplitude Accuracy	±0.5 %	
Frequency Response HDTV		
Y signal	±0.5 %	1 MHz to 30 MHz
C _B C _R Signal	±0.5 %	0.5 MHz to 15 MHz
Low-pass Attenuation	≥ 20 dB	at 20 MHz
Frequency Response SDTV		
Y signal	±0.5 %	1 MHz to 5.75 MHz
C _B C _R Signal	±0.5 %	0.5 MHz to 2.75 MHz
Low-pass Attenuation	≥ 20 dB	at 3.8 MHz
(3) Horizontal Axis		
Line Display	Display format	Overlay: 1H, 2H Parade: 1H, 2H, 3H Timing: 2H
	Magnification	Select x1, x10
	Active Display	Displays only the video period
	Blank Display	Displays blanking period expanded when set to overlay 2H
Field Display	Display format	Overlay: 1V, 2V 2V display not allowed for progressive Parade: 1V, 2V, 3V
	Magnification	Select x1, x20, x40
Time Base Accuracy	±0.5 %	
(4) Cursor Measurement		
Configuration	Horizontal cursors: 2 cursors (REF and DELTA) Vertical cursors: 2 cursors (REF and DELTA)	
Amplitude Measurement	Measured in [%] and [V]	
Time Measurement	Displayed in [usec] or [msec]	
Frequency Display	Displays the frequency in which the time between cursors is considered a cycle.	

2.3.5 Vectorscope Display

Sensitivity	Select 75 % or 100 % Using a color bar
Gain	Select x1, x5, IQ-MAG or variable
Variable gain	x0.2 to x10.0
Amplitude Accuracy	±0.5 %
Blanking Period	Displayed by masking
IQ Axis	Select show/hide
Pseudo-Composite Display	Artificially converts component signals into composite signals and displays the result
Line Select	Displays the selected line

2.3.6 Picture Display

HDTV Display	Displayed by sampling the pixels (when set to FIT)
SDTV Display	Displayed by interpolating pixels (when set to FIT)
Frame Rate	Converts the frame rate using the internal synchronization signal and displays the result
Marker Display	Center marker 4:3 or 16:9 marker display Safe action marker display Safe title marker display
Line Select	Displays a marker the selected line

2.3.7 Embedded Audio Display

(1) Quantization Accuracy	HDTV: 24 bits SDTV: 20 bits
(2) Lissajous Display	
Display Channel	Select 2-ch or 8-ch display
Display Method	Select X-Y or L-R
(3) Sound Image Display	
Display Channel	Select 3-1 ch, 3-2 ch, or 3-2-2 ch.
(4) Level Meter Display	
Display Channel	Simultaneous 8 ch display
Meter	Select 60 dB peak level, 90 dB peak level, or average response meter Peak level meter has a hold function
(5) Correlation Meter Display	Displays the phase between channels using a correlation meter
(6) Channel	
Group Selection	Select two arbitrary groups from groups 1, 2, 3, and 4
Ch Mapping	Mapping of L, R, SL(S), SR, C, LFE, RL, and RR is possible.

2.3.8 Status Display

(1) SDI Signal Status Display	
Signal Detection	Detects the presence or absence of SDI signals
CRC Error	Transmission error of HD-SDI signals
EDH Error	Transmission error of SD-SDI signals
BCH Error	Transmission error of embedded audio signals in the HD-SDI signal
Checksum Error	Transmission error of ancillary data
Parity Error	Detects parity errors in the ancillary data header

Gamut Error	Detects gamut errors
Detection Range	Upper limit: 90.0 % to 109.4 % Lower limit: -7.2 % to +6.0 % 0.1 % steps
Composite Gamut Error	Monitors the level error when the component signal is converted into composite signal
Detection Range	Upper limit: 90.0 % to 135.0 % Lower limit: -40 % to -20 % 0.1 % steps
Equivalent Cable Length Measurement	Displays the signal attenuation of the SDI signal by converting to cable length
Supported cables	HD-SDI Select L-7CHD, LS-5CFB, or 1694A SD-SDI Select LS-5C2V, 8281, or 1505A
Accuracy	±20 m
Resolution	5 m (10 m for L-7CHD)
Error Count	Up to 100,000 errors Counts only the specified errors
Count period	1 count even if multiple errors occur within 1 second
(2) Data Dump Display	
Display format	Displayed separately by serial data sequence or channel.
Line Select	Displays the selected line
Sample Select	Displays selected samples
Jump Function	Move to EAV or SAV by one-key operation
Data Output	Save data in text format to a PC via a compact flash memory card or Ethernet network.
(3) Event Log	
Number of Logs	Up to 1,000 events Select overwrite or update when the maximum number of events is exceeded
Operation	Logs events that occur from start to stop
Logged Items	Error items, input switching operation, time stamps, etc.
Data Output	Save data in text format to a PC via a compact flash memory card or Ethernet network.
(4) Audio Status	
Voice Control Packets	Analyzes and displays the voice control packets of the SDI signal
Channel Status	Dumps, analyzes, and displays the channel status of the embedded audio signal
(5) EDH display	
EDH	Displays the status of the EDH packets

2.3.9 Screen Capture

Capture	Captures the display screen Records 1 screen in the internal memory
Media	Internal memory (RAM) or compact flash card
Display	Displays the captured image by itself or by overlapping with the input signal
Data Output	Save data in B.M.P. format to a PC via a compact flash memory card or Ethernet network.

2.3.10 Presets

Number of Presets	30
Media	Internal memory or compact flash memory card
Recall Method	Through the front panel, remote connector, and Ethernet network Switch 8 points and 30 points for recalling through the remote connector
Copy	Copy presets collectively to the compact flash memory card or from the compact flash memory card to the LV 5750

2.3.11 Other Display Settings

(1) LCD	
Backlight brightness	Select high or low
Auto Shutoff	Set the time for the backlight to shut off automatically
(2) Display	
Format	Displays the input signal format at the top section of the screen Select show or hide
Color System	Displays YC _B C _R , GBR, RGB, or COMP depending on the setting Select show or hide
Date	Displays the data using the built-in calendar function Select year/month/day, month/day/year, day/month/year, or hide
Time	Displays the time using the built-in time function or the ATC embedded in the SDI signal (frame count is not displayed) Select show or hide
(3) Illumination of Key LEDs	
Illumination of All Key LEDs	Turns on all the LEDs corresponding to the keys

2.3.12 General Specifications

Environmental Conditions	
Operating Temperature	0 to 40 °C
Operating Humidity	≤ 85 % RH (without condensation)
Spec-Guaranteed Temperature	10 to 30 °C
Spec-Guaranteed Humidity	≤ 85 % RH (without condensation)
Operating Environment	Indoor and outdoor use
Operating Altitude	Up to 2,000 m
Overvoltage Category	I
Pollution Degree	2
Power Requirements	DC 12V (10 to 18V), 30 Wmax.
Dimensions and Weight	
	215 (W) x 133 (H) x 103 (D) mm (excluding projections)
	224 (W) x 147 (H) x 180 (D) mm (including projections)
	2.5 kg
Accessories	Instruction manual1

3. PANEL DESCRIPTION

3.1 Front Panel

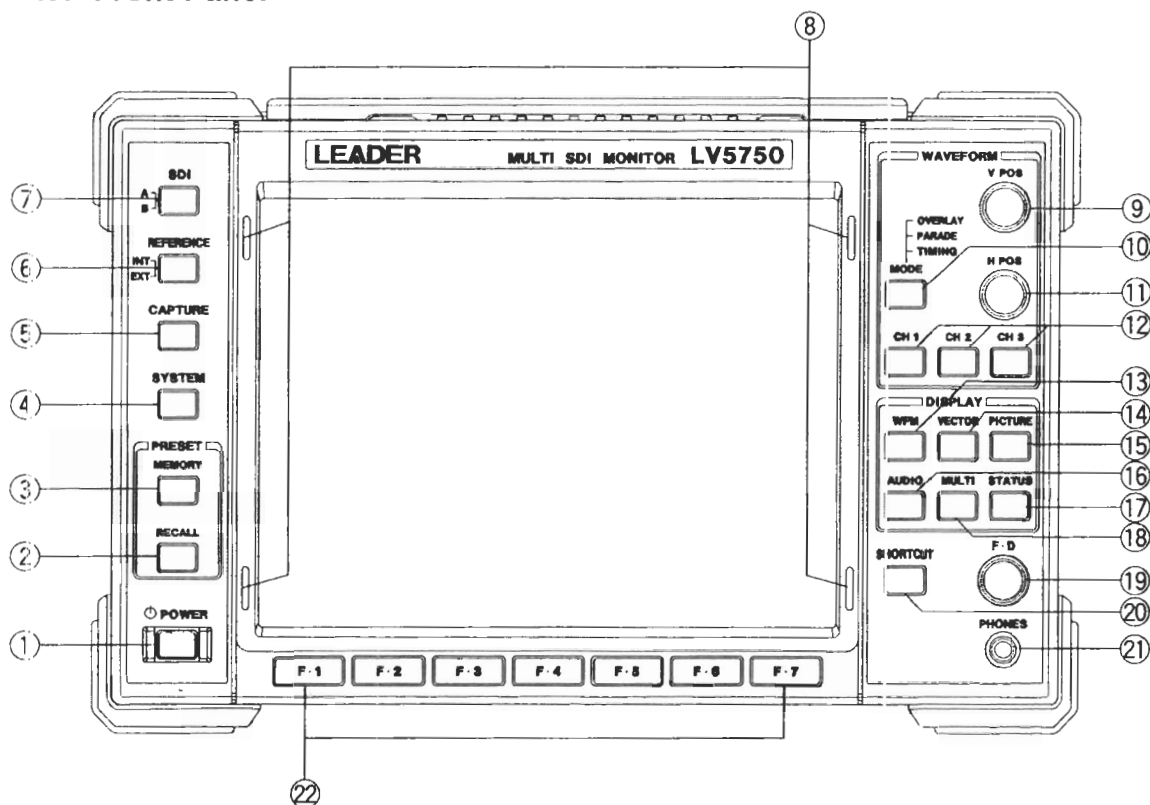

Figure 3.1 Front Panel

- ① POWER switch
Power switch. (The word "POWER" illuminates when the power can be turned ON.)
If a battery is attached when the power is OFF, the LED blinks.
If a power supply is connected to the XLR connector, the LED stays lit (not blinking).
- ② RECALL key
Displays a menu used to recall the settings saved to the preset memory.
- ③ MEMORY key
Stores the settings to the preset memory or sets the preset memory.
- ④ SYSTEM key
Displays the system menu. Enters settings related to the LV 5750 system.
- ⑤ CAPTURE key
Captures the screen. The capture image can also be saved.
- ⑥ REFERENCE key
Press this key to switch the synchronization of the video signal waveform display to INTERNAL (synchronization signal regenerated from the SDI signal) or EXTERNAL (external sync signal applied to the EXT REF connector ⑩).

- ⑦ SDI signal input selection key
Switches the input between INPUT A and INPUT B.
- ⑧ Hood attachment holes
Holes for attaching the optional viewing hood sold separately.
- ⑨ V POS control
Adjusts the vertical position on the waveform display.
Press the control to reset the vertical position of the waveform to default.
- ⑩ MODE key (MODE)
Switches the display mode of WFM waveforms.
OVERLAY displays channels 1, 2, and 3 overlaid.
PARADE displays channels 1, 2, and 3 side by side.
TIMING is used when performing timing measurements such as for bowtie displays.
- ⑪ H POS control
Adjusts the horizontal position on the waveform display.
Press the control to reset the horizontal position of the waveform to default.
- ⑫ CH1, CH2, and CH3 keys
Selects the channel from CH1, CH2, and CH3 to be shown on the waveform display.
The keys can be turned ON/OFF independently; the LED of the selected key turns on.
However, you cannot turn OFF all the channels simultaneously.
- ⑬ Waveform key (WFM)
Displays waveforms.
- ⑭ VECTOR key (VECTOR)
Displays vector waveforms.
- ⑮ PICTURE key (PICTURE)
Displays pictures.
- ⑯ AUDIO key
Shows the lissajous display, level meter, and other displays of embedded audio.
- ⑰ STATUS key
Displays the status of the input signal.
- ⑱ MULTI key
Displays multiple items at once.
- ⑲ Function Dial (F·D)
Function dial for entering values and settings on each menu.
Press the dial to reset the step (resolution) setting in various menus to its default.
- ⑳ SHORTCUT key
One of several functions can be assigned through user setting.

- ⑳ Headphone socket
Outputs the embedded audio signal in the SDI signal to the headphone.
The output channel and volume are set in chapter 9, "Audio Display."
All audio signals synchronize to the video clock of the SDI signal. If the signal is out of synchronization, noise will be generated.
- ㉑ Function keys (F.1 to F.7)
Function keys used to enter settings on the menu.

3.2 Rear Panel

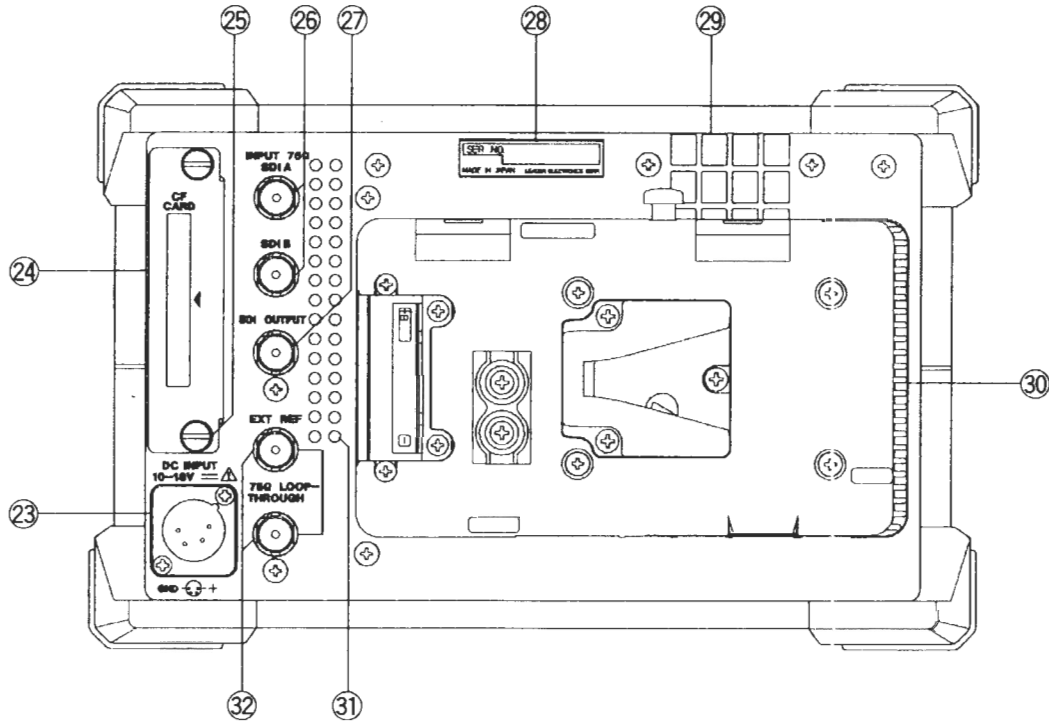

Figure 3.2 Rear Panel

- ㉒ DC power input connector
An XLR DC power input connector. For details, see section 3.4, "Power Supply."
- ㉓ External IF slot
By inserting a dedicated interface card, various functions can be added such as saving/loading data from the compact flash card, controlling the LV 5750 via the Ethernet interface, and recalling presets using the remote connector. The Compact Flash Card Unit is installed as standard.
Only one unit can be installed to the external IF slot.
* The number of times a unit can be inserted and removed is 500.
If this number is exceeded, the unit may fail to operate properly due to poor contact or other reasons.
- ㉔ Unit attachment screw
A screw used when installing or removing a unit from the external IF slot ㉓.

②6 SDI signal input connector

Input connector for serial digital signals. Two systems (A and B) are provided. The input is internally terminated at 75 Ω .

⚠ CAUTION

Do not apply a voltage exceeding ± 2 V (DC + peak AC) to the SDI signal input connector. If you do, the LV 5750 may malfunction.

②7 SDI signal output connector (SDI OUTPUT)

HD-SDI or SD-SDI signal output. Retransmits the signal by reclocking the signal selected using the SDI signal input selection key (SDI) ⑦.

Use this signal by connecting to the picture monitor with an SDI input, for example.

⚠ CAUTION

Do not apply signals to the output connector. If you do, the instrument may malfunction.

⚠ CAUTION

Do not apply a voltage exceeding ± 5 V (DC + peak AC) to the external synchronization input connector.

If you do, the instrument may malfunction.

②8 Serial number label

Instrument serial number. Provide the number on the label when contacting Leader.

②9 Fan

Exhaust fan for internal cooling. Be sure not to obstruct air circulation.

⚠ CAUTION

Using the instrument with the fan air circulation blocked for an extended time can cause a malfunction.

③0 Battery plate

Attachment plate for V-mount batteries. For details, see section 3.4, "Power Supply."

③1 Vent holes

Inlet vent holes for internal cooling. Be sure not to obstruct air circulation.

⚠ CAUTION

Using the instrument with the fan air circulation blocked for an extended time can cause a malfunction.

③2 EXT REF connector

Accepts external sync signal. The input configuration is loop-through.

Supports HD tri-level sync signal or NTSC/PAL black burst signal.

3.3 Top and Bottom Panels

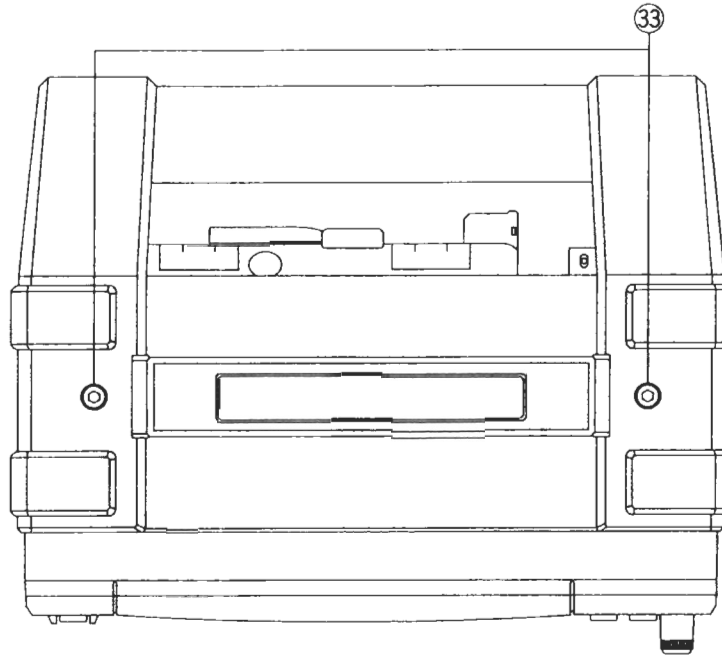

Figure 3.3 Top panel

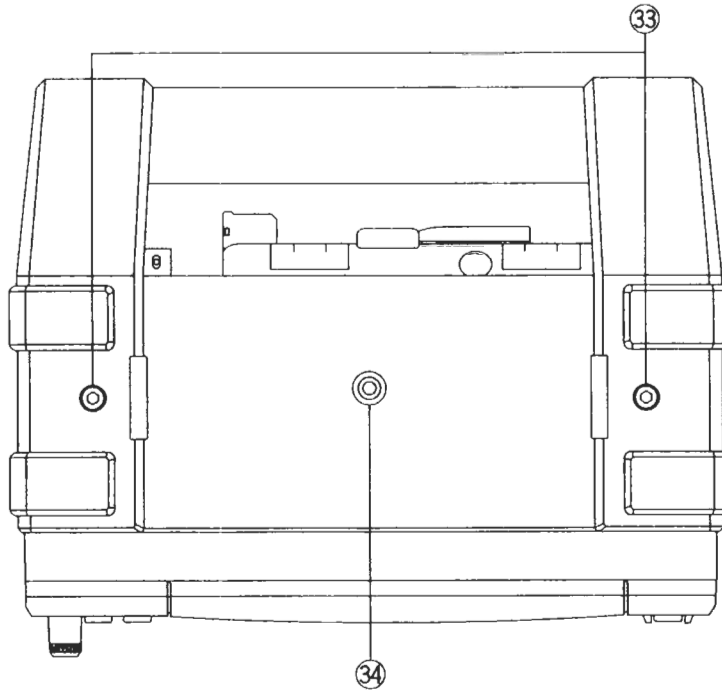

Figure 3.4 Bottom panel

③ Hexagonal screws for removing the case

Screws for removing the case when rack mounting the instrument.

Remove the case using a hexagonal socket wrench with 3 mm width.

You can remove the case by unfastening the screws and shifting the case backward.

If you are using the instrument by carrying it around different locations, be sure use the instrument with the cover attached.

④ Screw hole for tripod

A hole used to mount the instrument on a tripod.

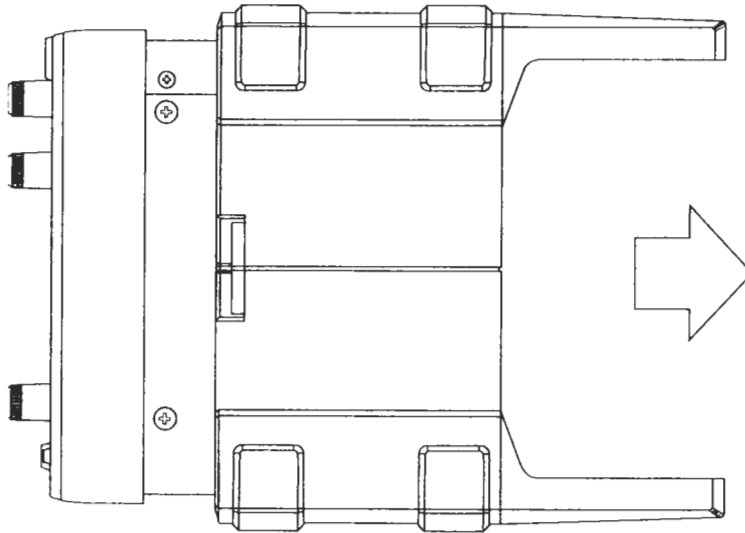

Figure 3.5 Direction for removing the case (side panel)

3.4 Power Supply

The input voltage range is 10 V to 18 VDC.

If you connect both the power supply (battery) attached to the battery plate ⑩ and the DC power input connector, the power from the DC power input connector takes precedence.

If you connect a battery or the DC power supply, the internal microprocessor is set to standby condition even when the power switch is turned OFF. Consequently, a small amount of power is consumed. If you are not using the LV 5750 for an extended time, disconnect the battery and DC power supply.

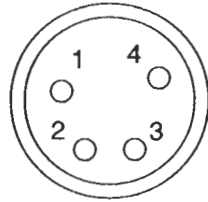

Pin No.	Pin Name
1	GND
2	NC
3	NC
4	+12V

* Do not connect anything to NC.

⚠ CAUTION

The case is negative ground. When using DC input, use caution when connecting equipment that is positive ground. If you reverse the DC input connection or if a positive power supply touches the case, the internal circuit may break.

⚠ CAUTION

Use the DC power supply within the ratings. Otherwise, a malfunction can occur. The LV 5750 may not operate properly when a power supply outside the ratings is used.

3.5 Power Switch

The POWER switch ① turns ON/OFF the power.

The power to the LV 5750 is turned OFF by holding down the switch for 1 second to prevent the power from being turned OFF inadvertently while the monitoring is in progress. You do not have to hold down the switch when turning ON the power.

When the power is turned ON, the POWER switch ① LED illuminates and the operation of the LV 5750 starts.

If a battery is attached when the power is OFF, the LED blinks. If a power supply is connected to the XLR connector, the LED stays lit (not blinking).

If the battery runs out and the LV 5750 stops while the power is turned ON, the LV 5750 will start at the power-on condition when you install a new battery.

POWER switch LED ① operation	
OFF	Standby mode. Only the internal microprocessor is running.
Blinking	Standby mode. A battery is installed in the V-mount adapter. The battery voltage is within the ratings.
ON	Running. The line voltage is within the ratings and the LV 5750 is running.

3.6 Connections to the Rear Panel Connectors

3.6.1 SDI INPUT Connector

The SDI INPUT connector ②⑥ (INPUT SDI A, B) is terminated internally at 75 Ω . You do not need to connect a terminator. Use a cable with a characteristic impedance of 75 Ω for the connection.

⚠ CAUTION

Applying excessive input voltage to the connector can cause damage to the instrument.

Do not apply excessive voltage.

3.6.2 EXT REF Connector

The EXT REF connectors ③② are of loop-through configuration. Loop-through connectors are connected as shown in Figure 3.6.

Apply the input signal to either connector and terminate the other connector with a 75 Ω terminator or 75 Ω equipment. Make sure to terminate the end of the chain. Use a cable with a characteristic impedance of 75 Ω for the connection.

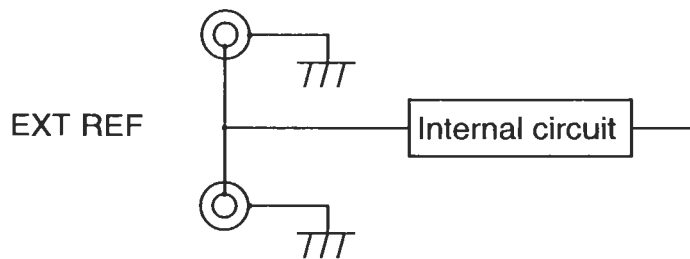

Figure 3.6 Loop-through input

3.6.3 SDI OUTPUT Connector

Use the SDI OUTPUT connector ②⑦ by connecting it to a picture monitor that supports SDI input. The output impedance is 75 Ω . Thus, terminate the other end at 75 Ω .

⚠ CAUTION

Do not apply signals to the output connector. Doing so can lead to malfunction.

3.7 External IF Slot

There are three types of dedicated external interface units available for the external IF slot (24).

The Compact Flash Card Unit is installed on the standard model. Ethernet Unit and Remote Control Unit are available as options.

Only one of the units above can be installed to the external IF slot. When installing an optional unit, remove the Compact Flash Card Unit.

To remove a unit, turn the unit attachment screws (25) using a driver or a similar tool and remove the unit carefully. To install a unit, check the direction and carefully insert the unit board along the slot guide.

⚠ CAUTION

When installing or removing a unit from the external IF slot, be sure to disconnect the DC power supply or battery (with no power supplied to the LV 5750).

In particular, installing or removing a unit with the power turned ON can cause a malfunction.

* The number of times a unit can be inserted and removed is 500.

If this number is exceeded, the unit may fail to operate properly due to poor contact or other reasons.

3.7.1 Compact Flash Card Unit

The Compact Flash Card Unit is a unit that is installed to the external IF slot (24) as standard. It can be used to save captured data, data dumps, event logs, preset data, etc.

Format the compact flash card to FAT16 before use. Other formats such as FAT32 and NTFS will not be detected.

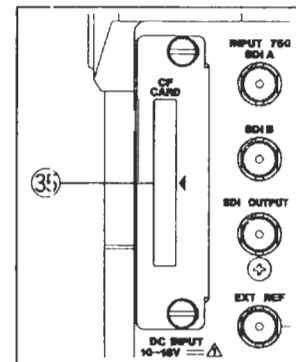

Figure 3.7 CF CARD slot (35)

3.7.2 Ethernet Unit

If you install the Ethernet Unit, the LV 5750 can be controlled remotely using a PC via the Ethernet network.

The Ethernet Unit is an option sold separately. Remove the Compact Flash Card Unit that comes standard and insert the Ethernet Unit in its place.

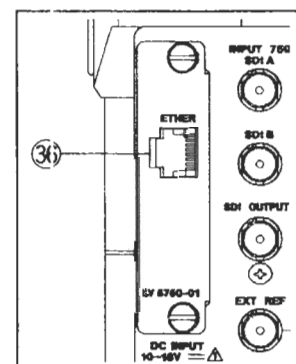

Figure 3.3 Ethernet Connector (ETHER) (36)

3.7.3 Remote Control Unit

The Remote Control Unit can be used to recall preset information using remote control. The Remote Control Unit is an option sold separately.

Remove the Compact Flash Card Unit that comes standard and insert the Remote Control Unit in its place.

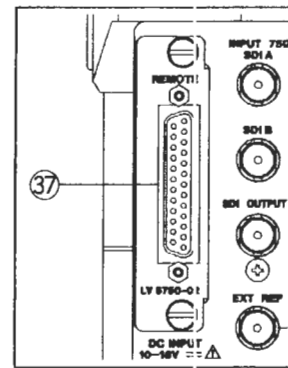
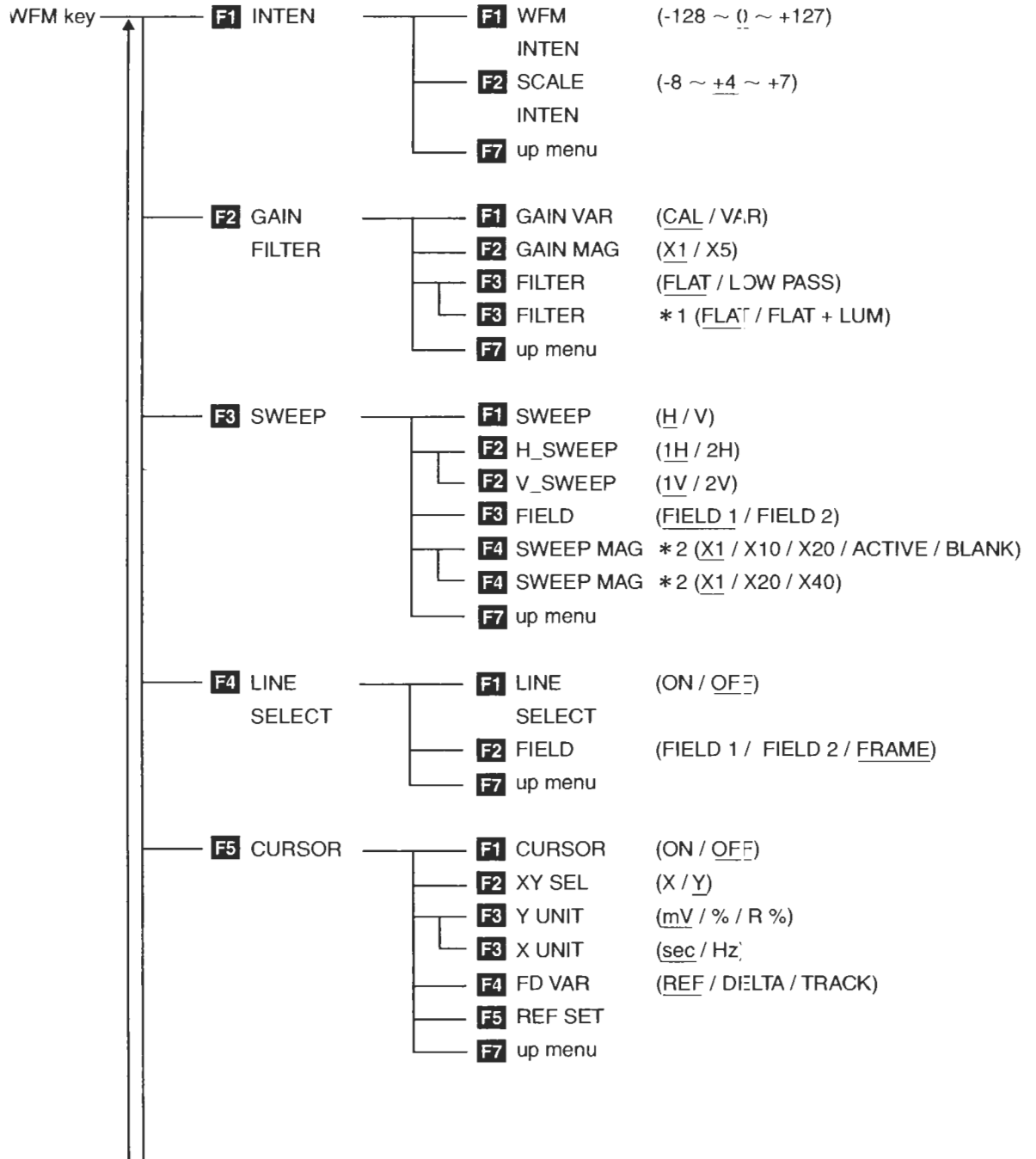

Figure 3.9 REMOTE Connector 37

4. MENU STRUCTURE

The structure of the menu assigned to the front panel keys is shown below. Underlined sections indicate initial settings.

4.1 Waveform Display Menu



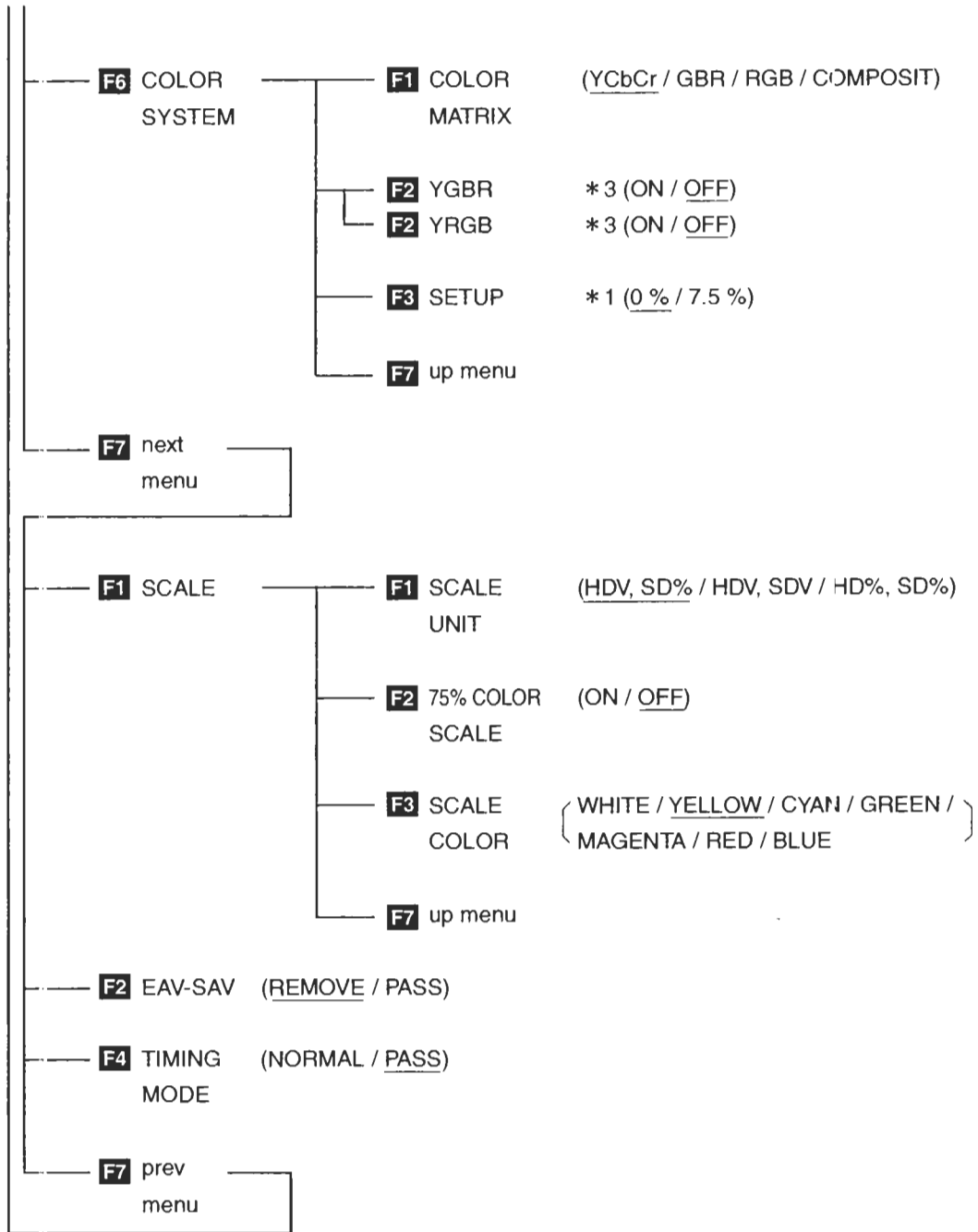

- * 1 Menu shown during pseudo-composite display.
- * 2 The selectable items vary depending on the video signal format, display mode, and other parameters.
- * 3 Menu shown during G, B, R or R, G, B display.

4.2 Vectorscope Display Menu

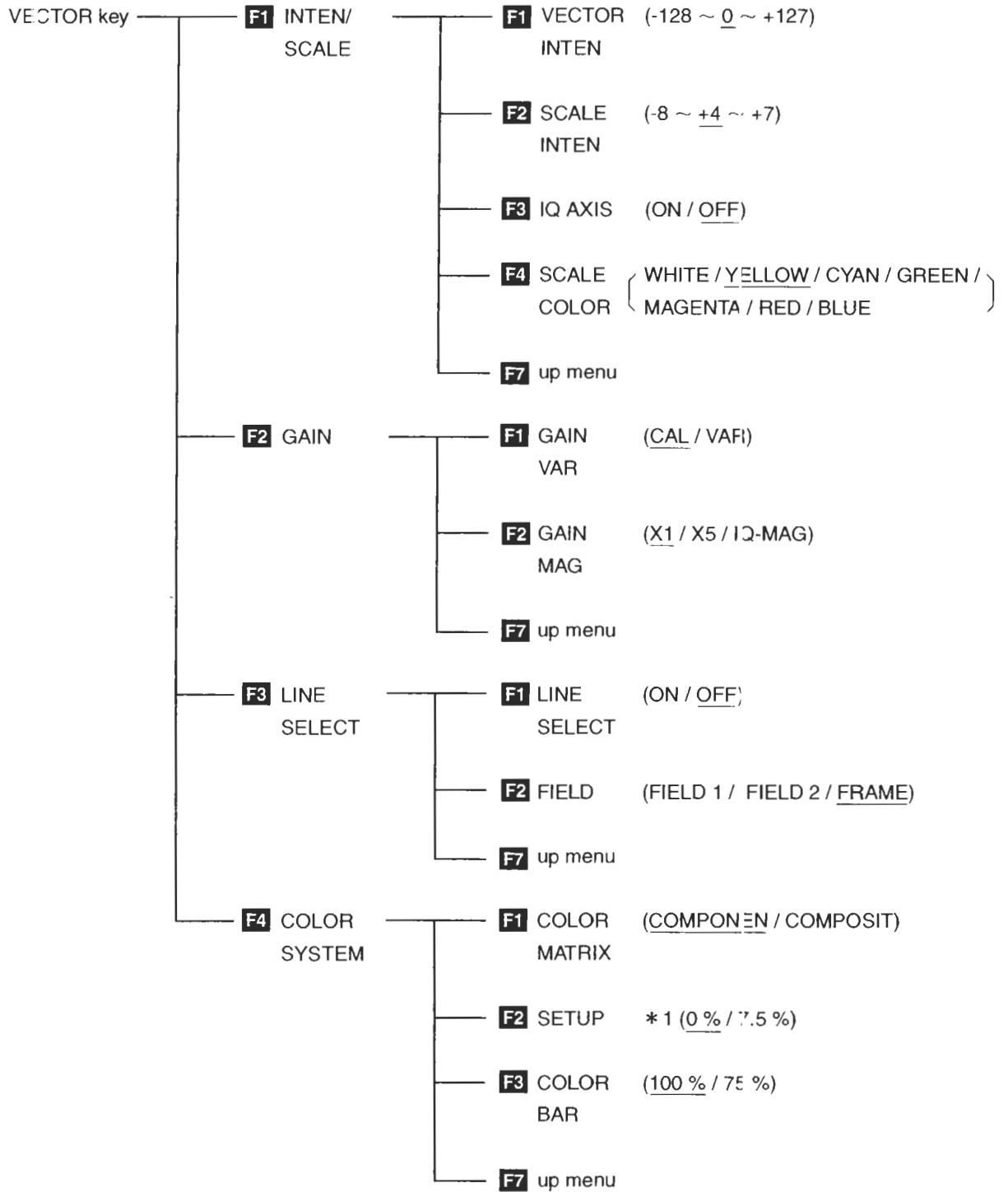

* 1 Menu shown during pseudo-composite display.

4.3 Picture Display Menu

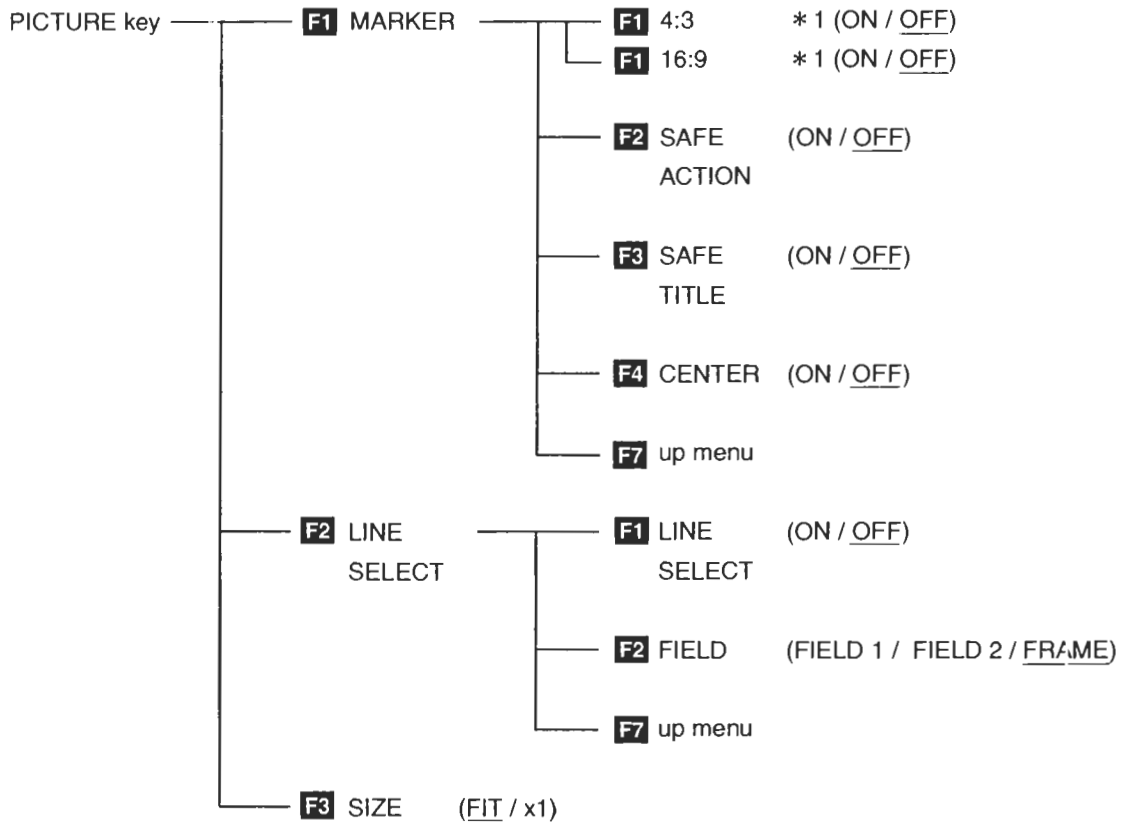

* 1 Varies depending on whether the input signal is HD-SDI or SD-SDI.

4.4 Audio Display Menu

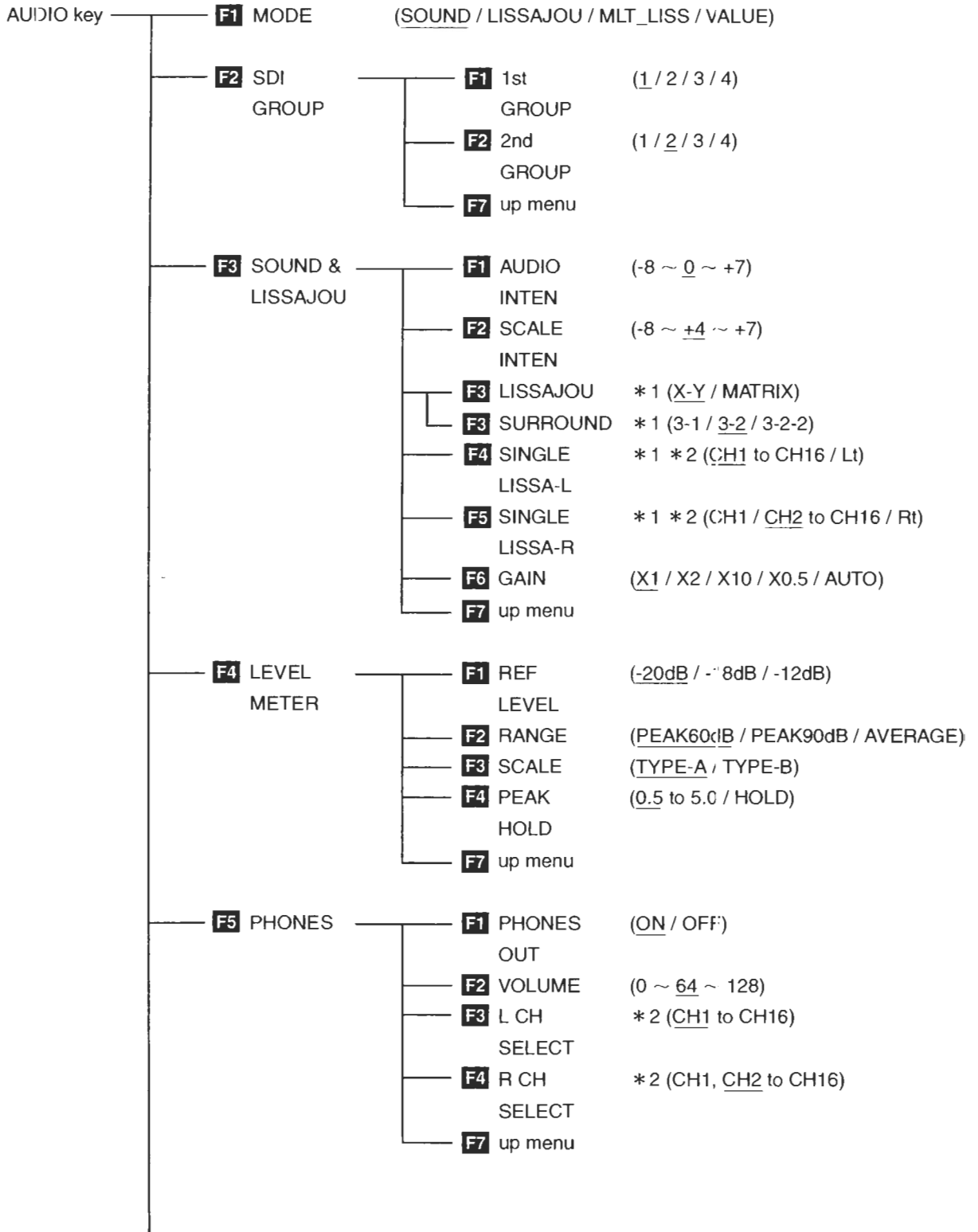

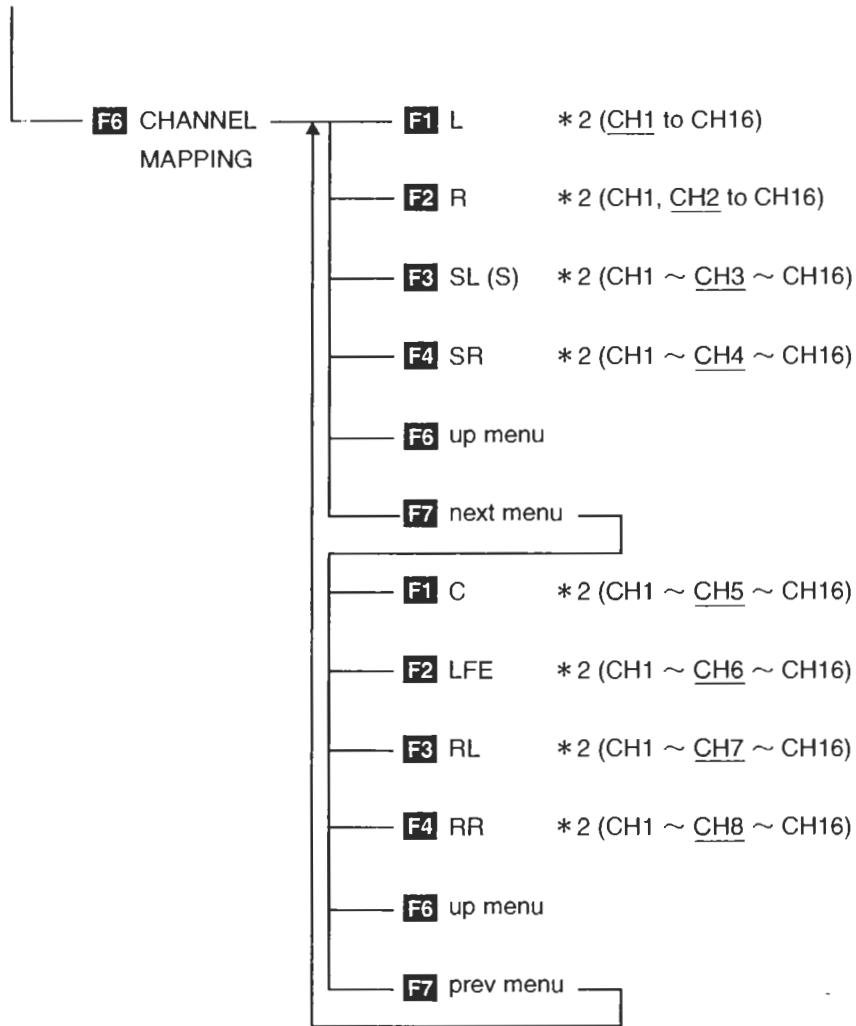

- * 1 Varies depending on whether the display mode is sound image, single lissajous, or multi lissajous.
- * 2 Varies depending on the 1st GROUP and 2nd GROUP selections.

4.5 Multi Display Menu

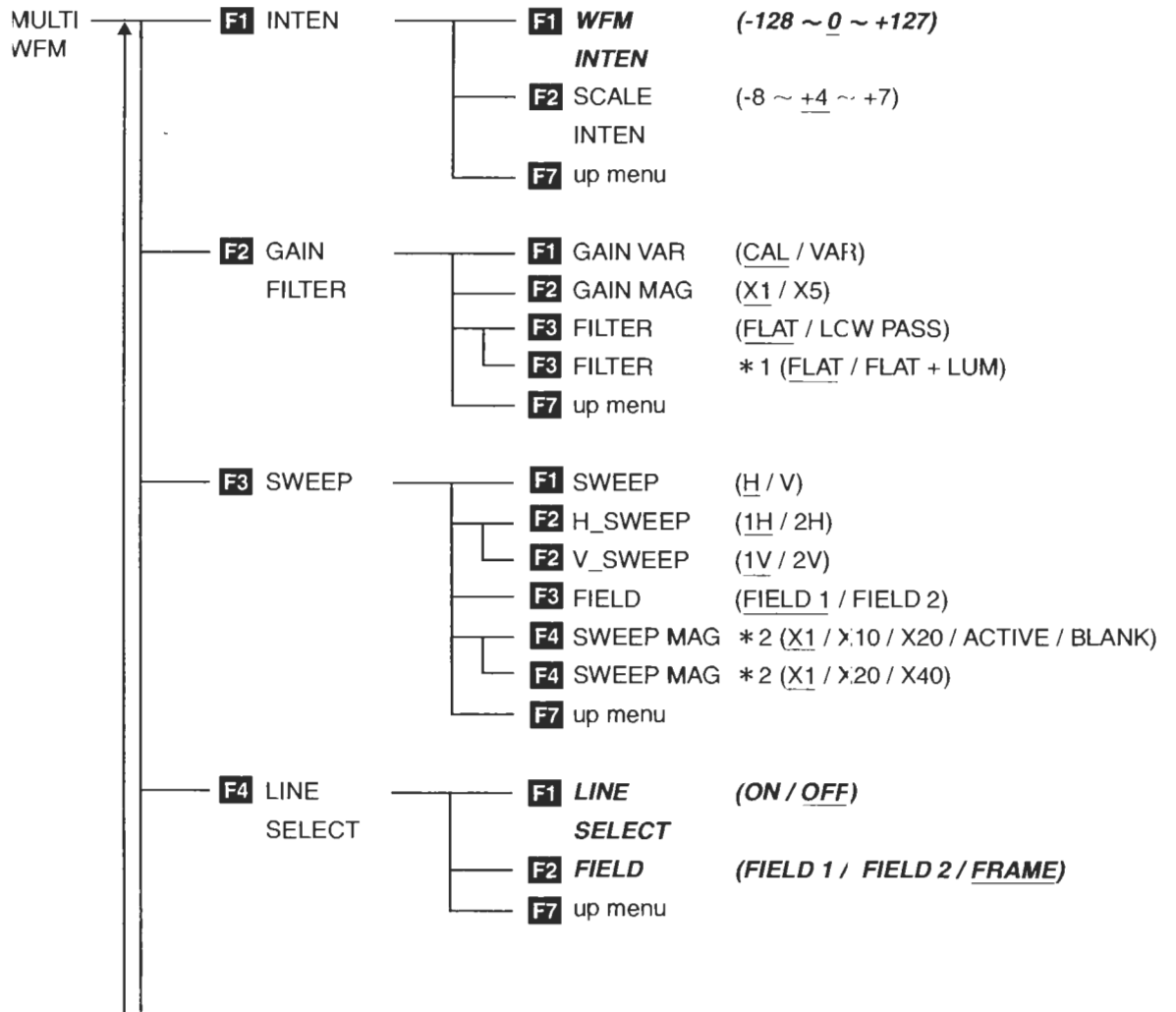
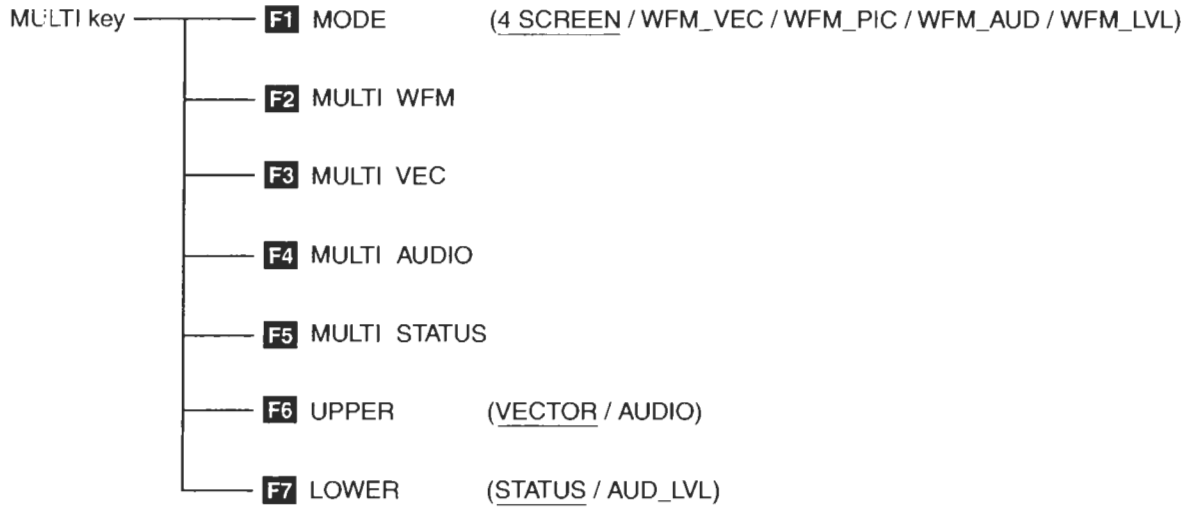

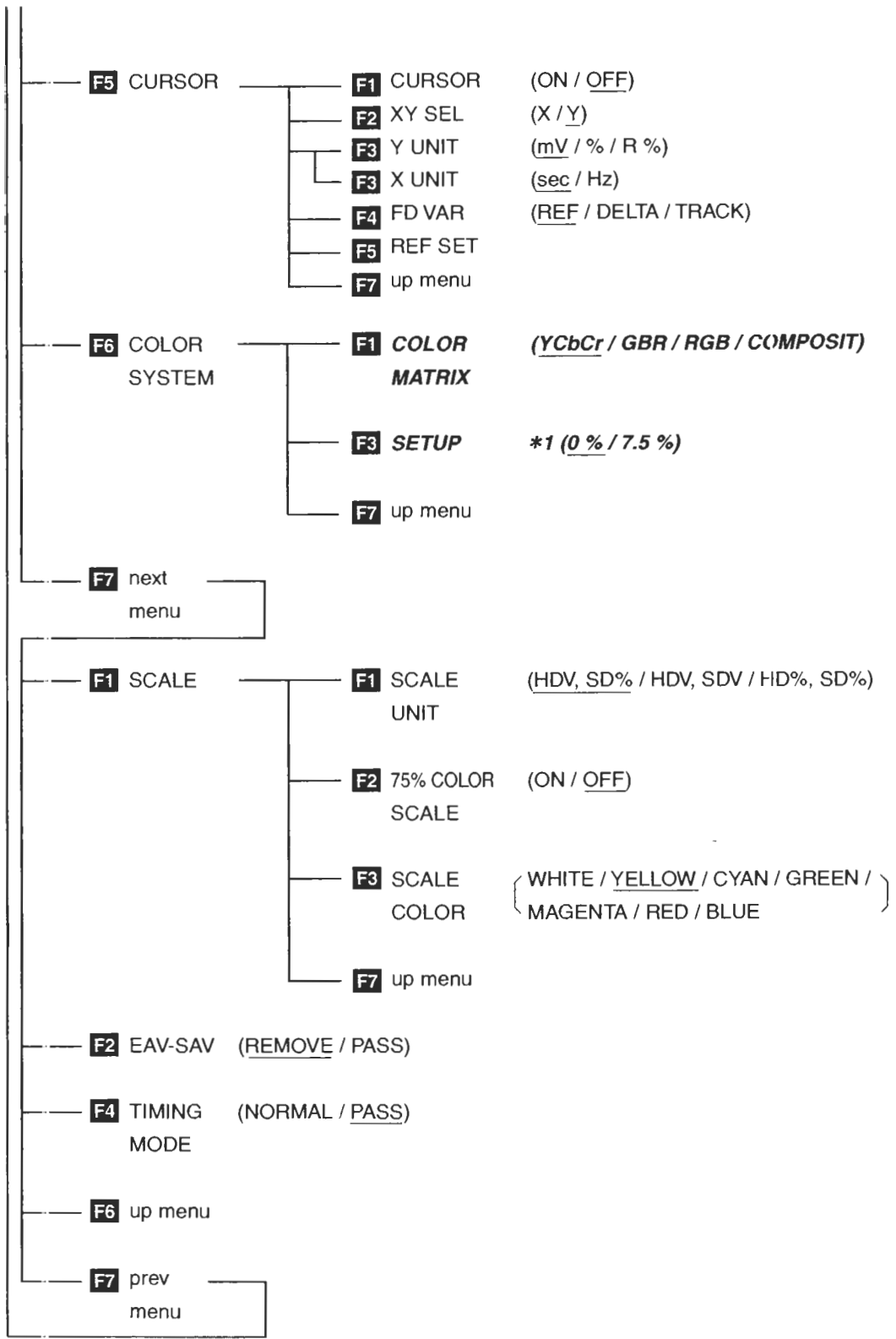

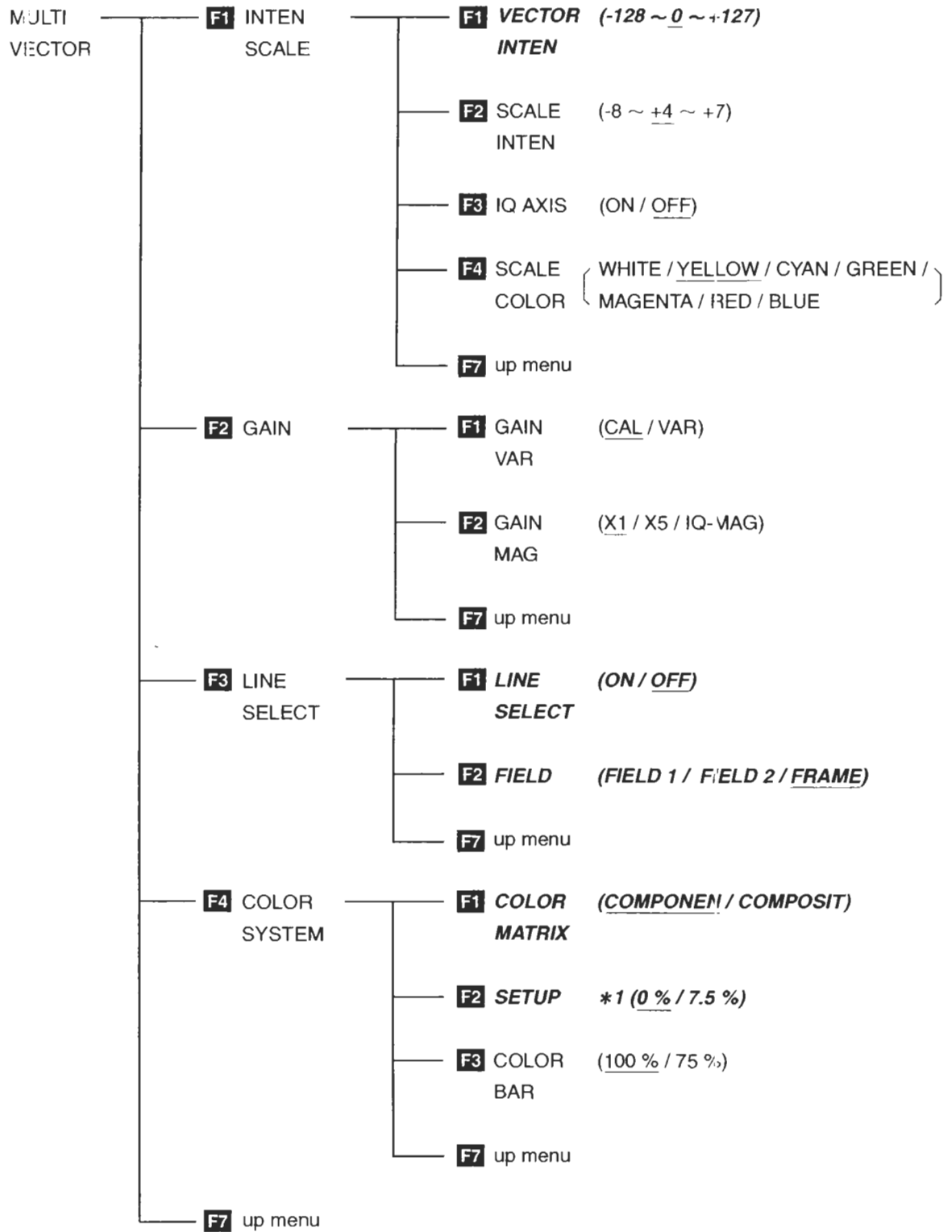

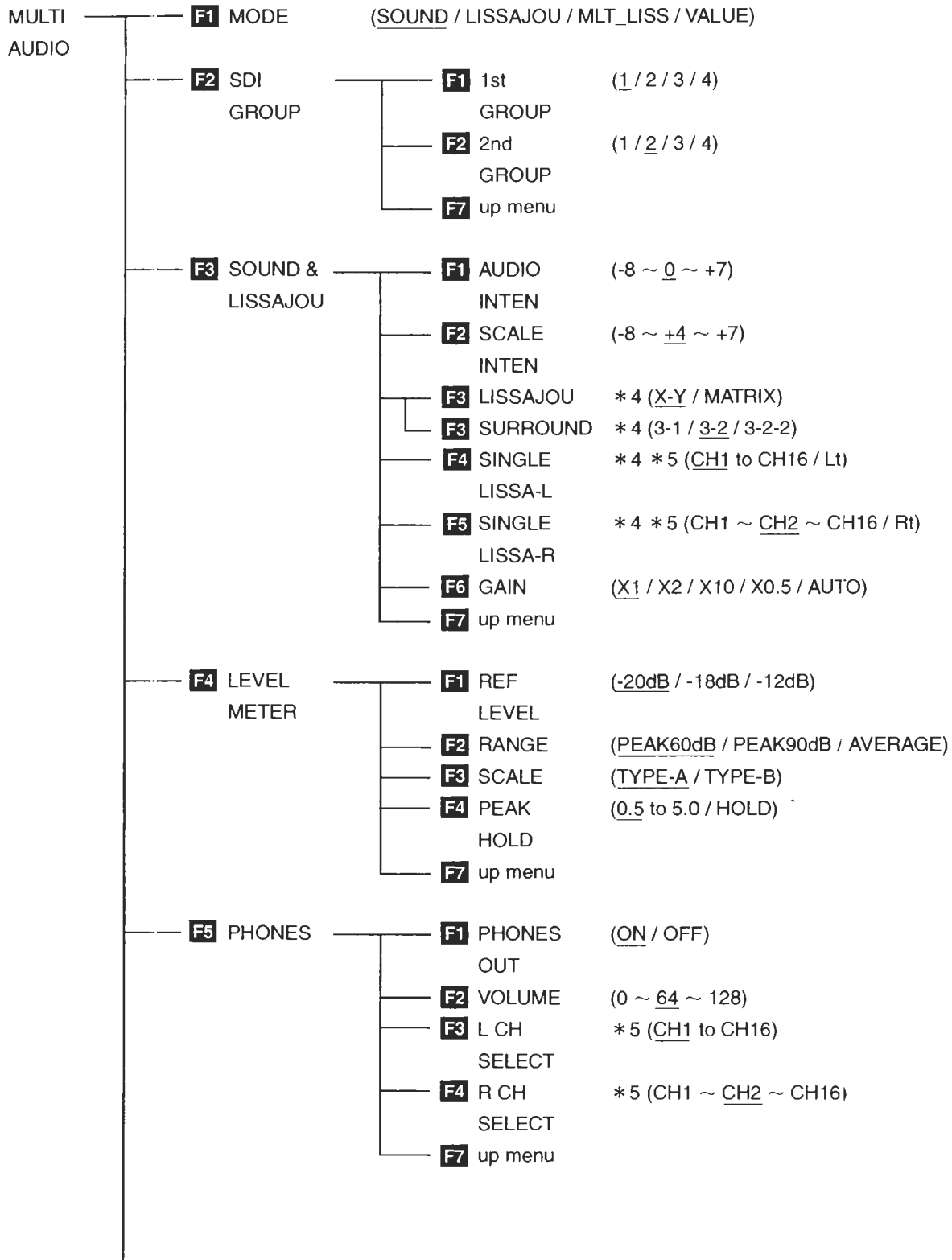

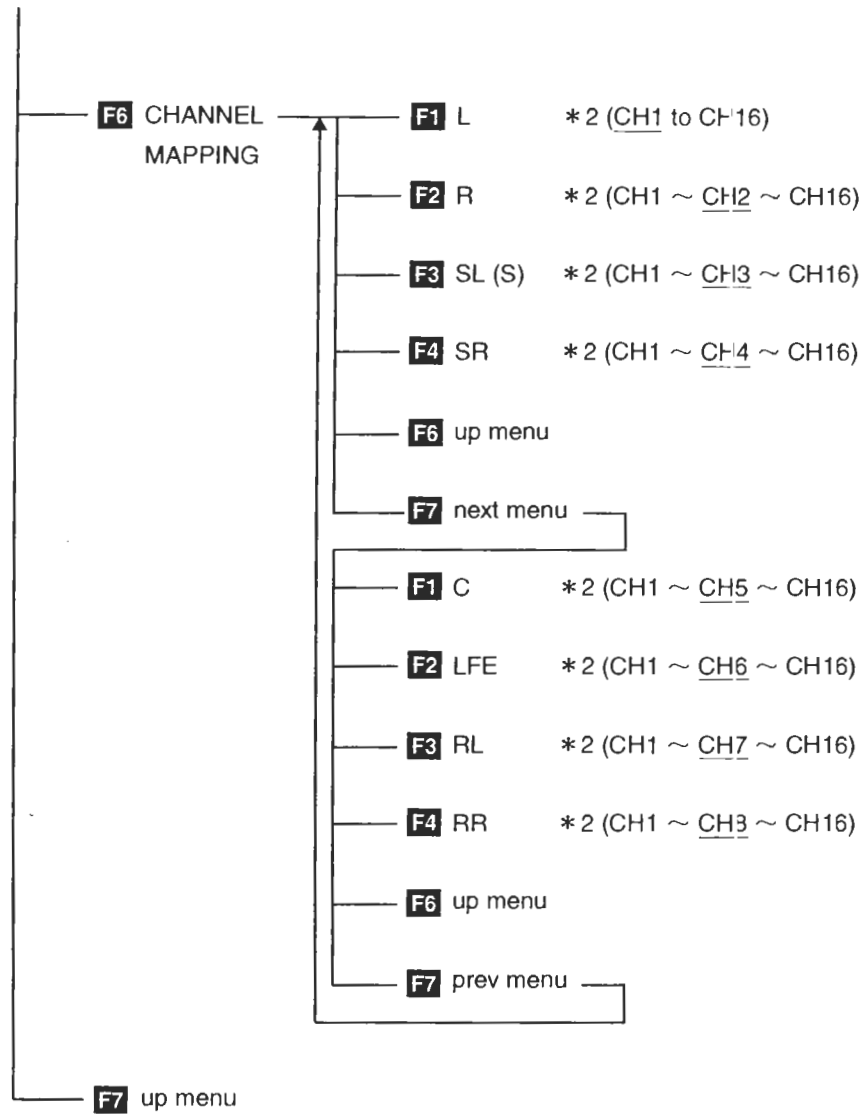

MULTI
STATUS

F1 LOG

F1 LIST

F2 LOG (START / STOP)

F3 CLEAR

F4 LOG (OVER WR / STOP)

MODE

F6 CF CARD
* 6

F1 NAME
INPUT

F1 CLEAR
ALL

F2 DELETE

F3 INSERT

F4 ←

F5 →

F6 CHAR
SET

F7 up menu

F2 STORE
CARD

F1 OVER WR
YES

F3 OVER WR
NO

F3 FILE
LIST

F4 FILE
DELETE

F1 DELETE
YES

F3 DELETE
NO

F5 FILENAME (ON / OFF)
AUTO INC

F7 up menu

F7 up menu

F2 DATA
DUMP

F1 MODE (RUN / HOLD)

F2 DISPLAY (SERIAL / COMPO / BINARY)

F3 EAV JUMP

F4 SAV JUMP

F5 F. D (LINE / SAMPLE)

F6 CF CARD
* 6

F1 NAME
INPUT

F1 CLEAR
ALL

F2 DELETE

F3 INSERT

F4 ←

F5 →

F6 CHAR
SET

F7 up menu

F2 STORE
CARD

F1 OVER WR
YES

F3 OVER WR
NO

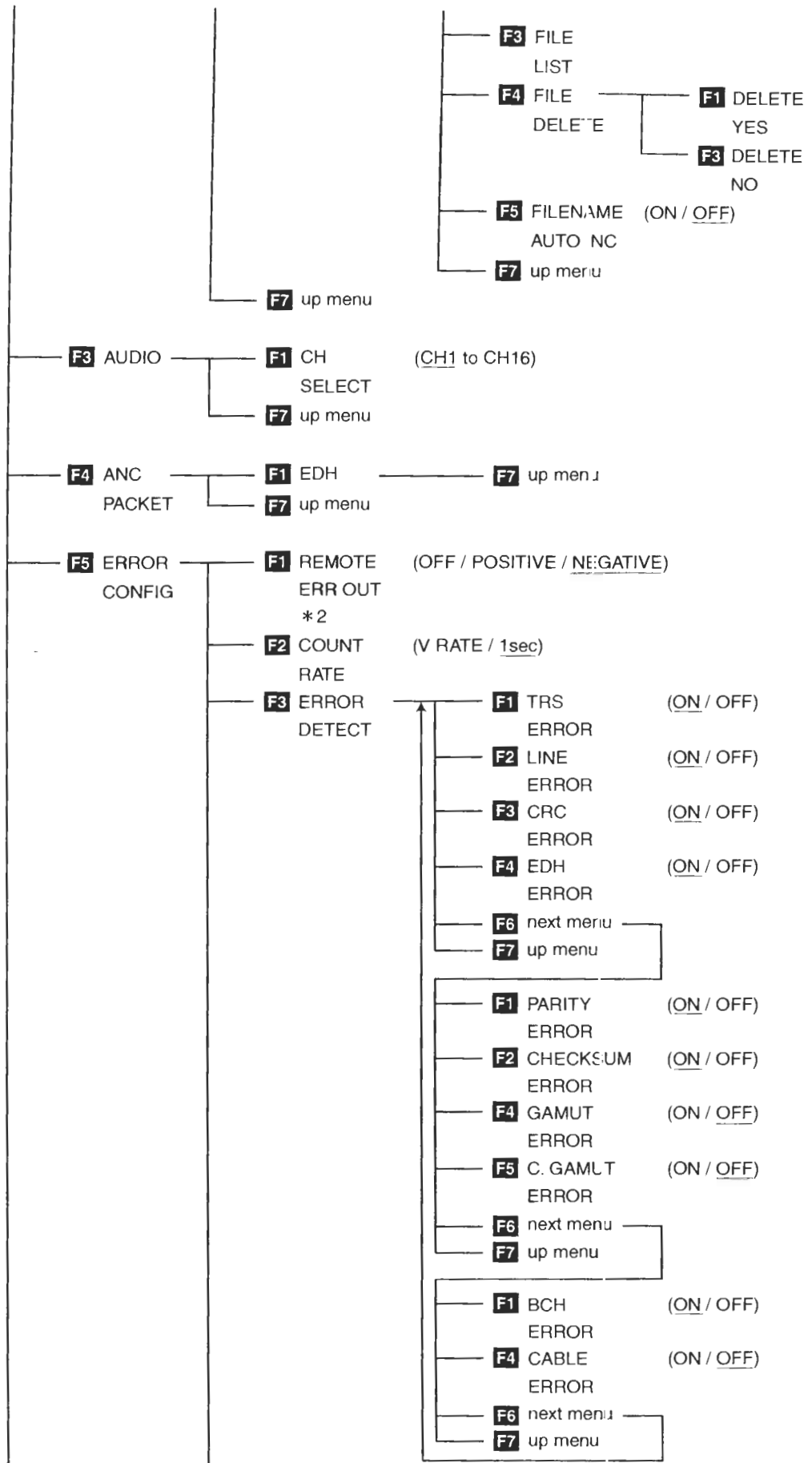

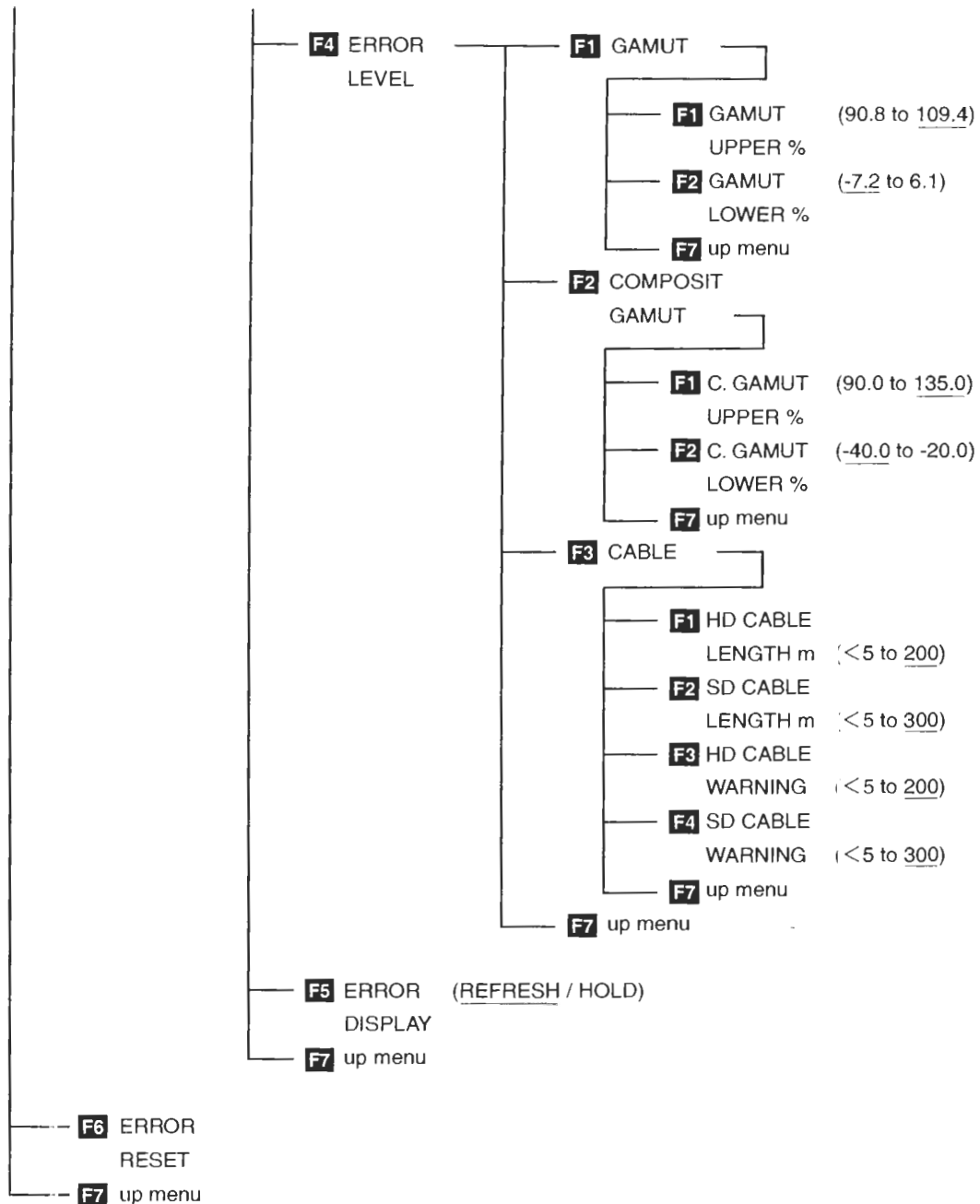

- * 1 Menu shown during pseudo-composite display.
 - * 2 The selectable items vary depending on the video signal format, display mode, and other parameters.
 - * 3 Menu shown during G, B, R or R, G, B display.
 - * 4 Varies depending on whether the display mode is sound image, single lissajous, or multi lissajous.
 - * 5 Varies depending on the 1st GROUP and 2nd GROUP selections.
 - * 6 Menu shown when the Compact Flash Memory Card Unit that comes standard is inserted.
 - * 7 Menu shown when the Remote Control Unit that is sold separately is inserted.
- Items indicated by italics are common settings for MULTI WFM and MULTI VEC. They cannot be set individually.

4.6 Status Display Menu

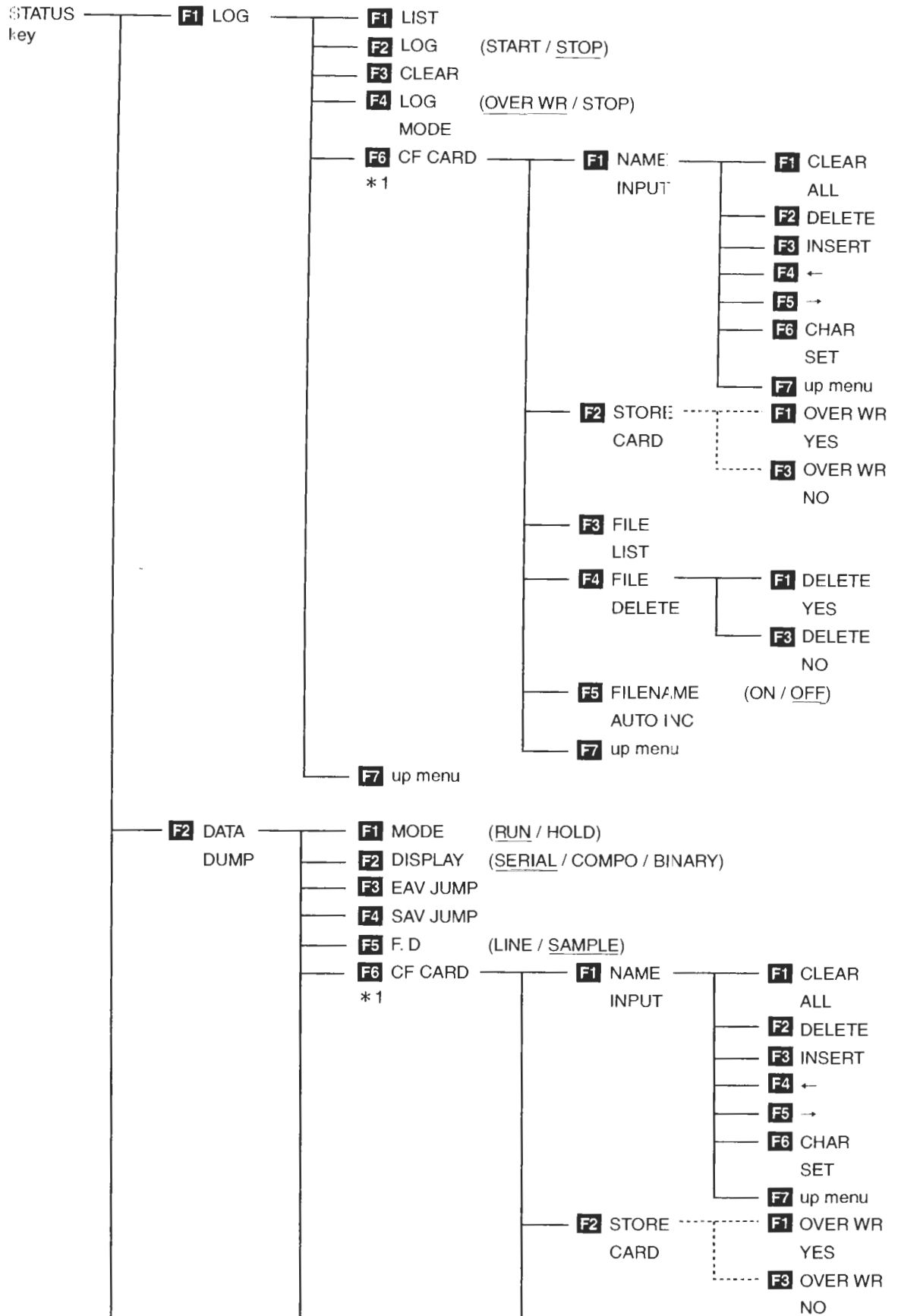

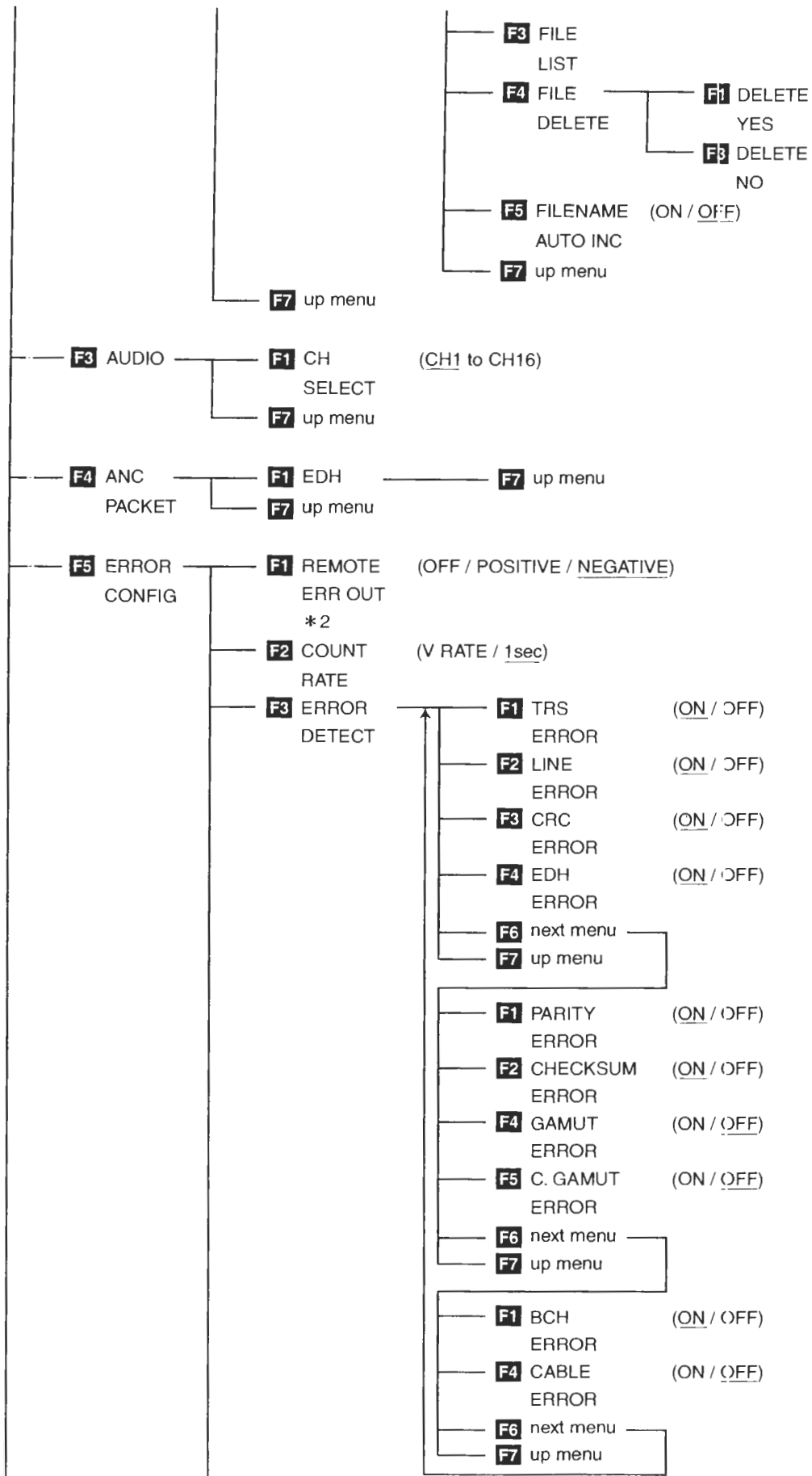

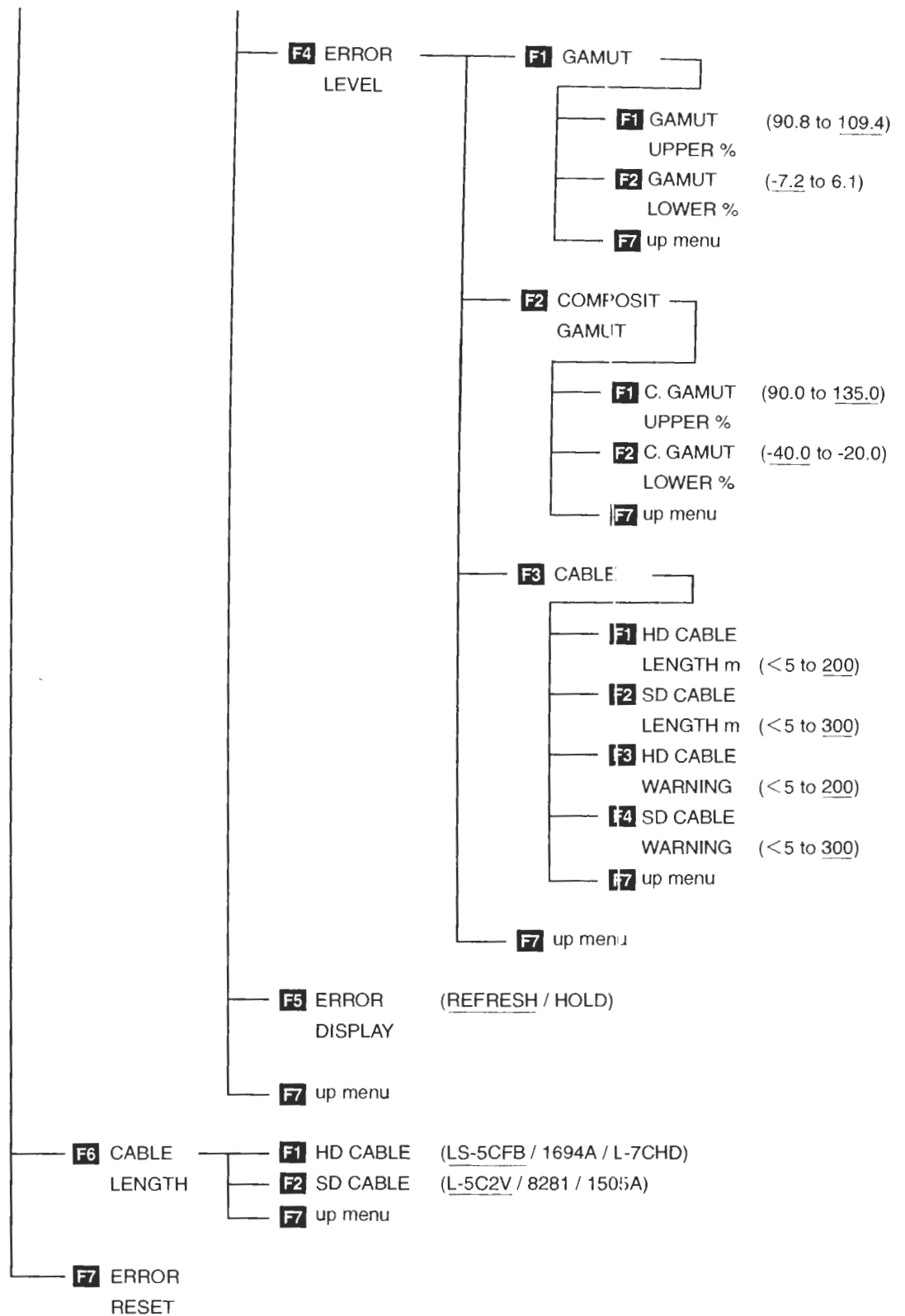

* 1 Menu shown when the Compact Flash Memory Card Unit that comes standard is inserted.

* 2 Menu shown when the Remote Control Unit that is sold separately is inserted.

4.7 Capture Menu

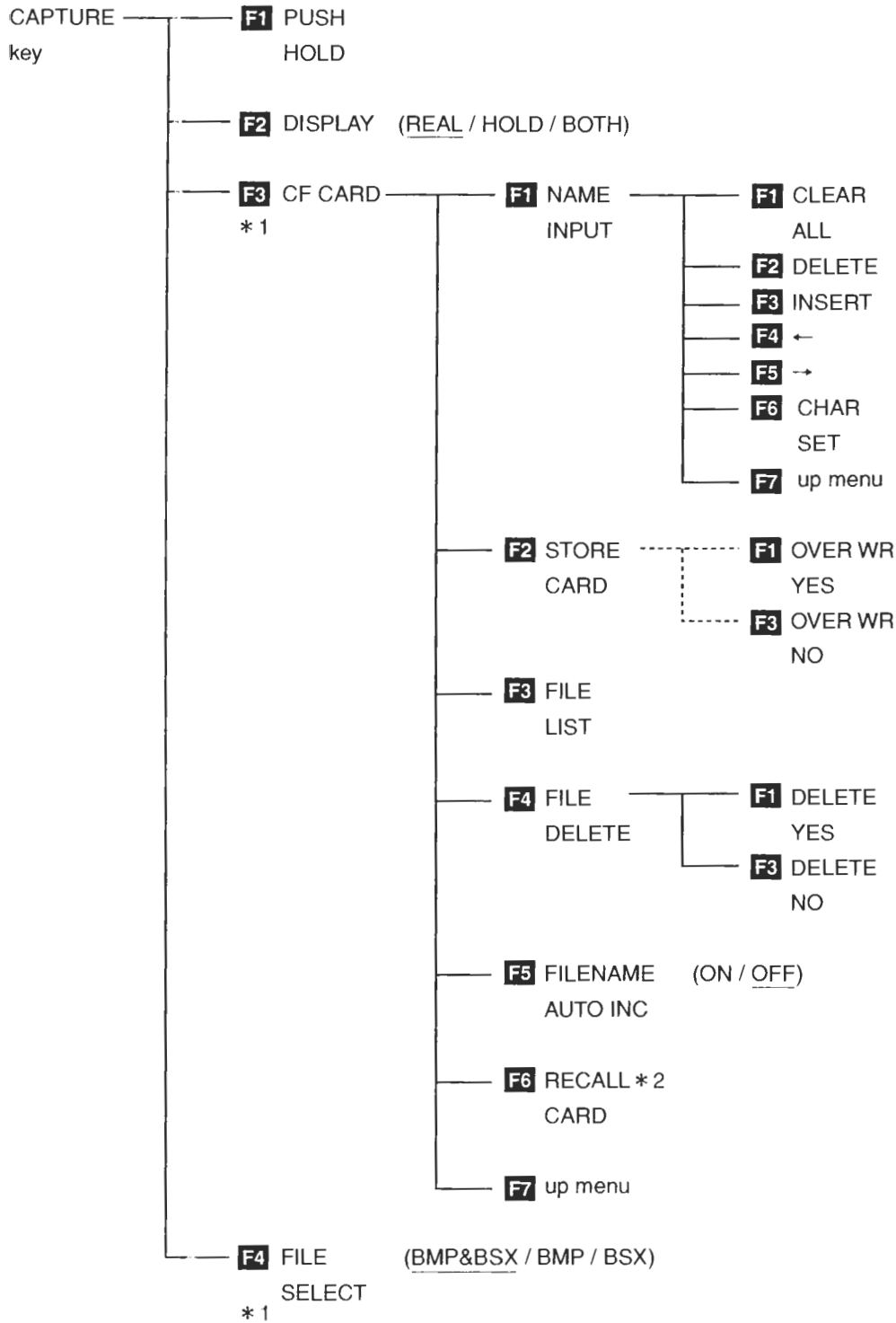

* 1 Menu shown when the Compact Flash Memory Card Unit that comes standard is inserted.

* 2 Displayed when the cursor is on a recallable file (.BSX extension).

4.8 System Menu

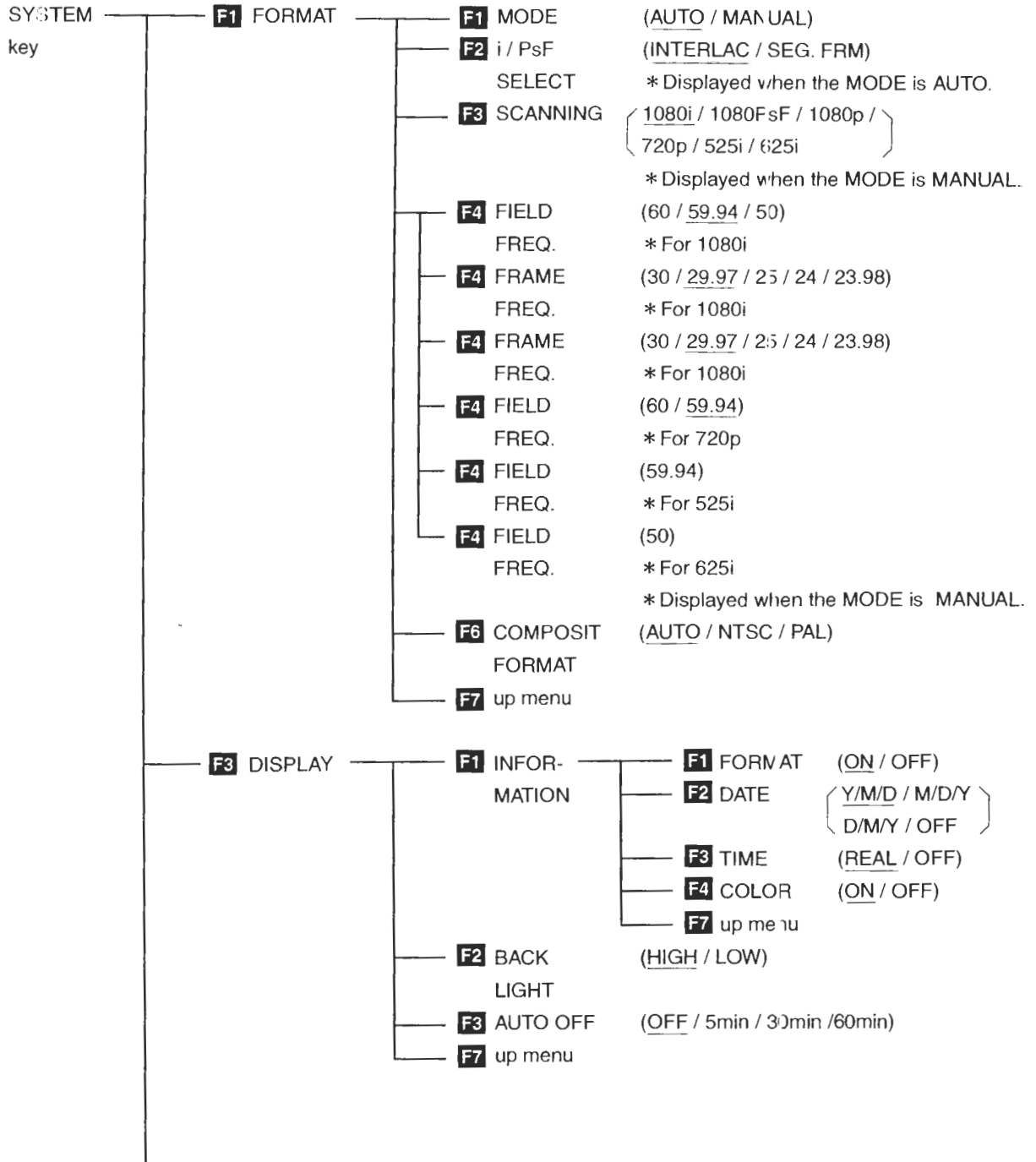

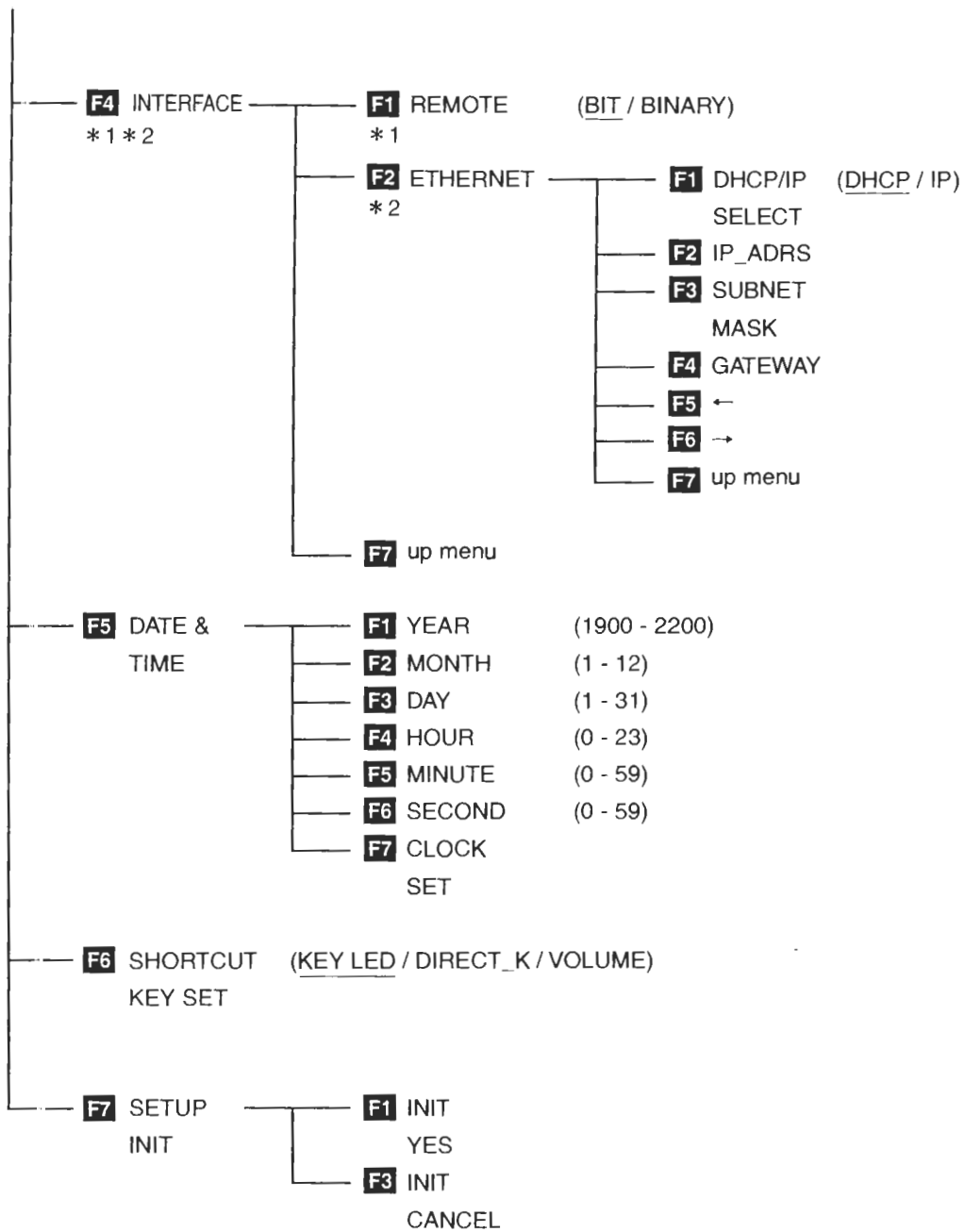

* 1 Menu shown when the Remote Control Unit that is sold separately is inserted.

* 2 Menu shown when the Ethernet Unit that is sold separately is inserted.

4.9 Preset Menu

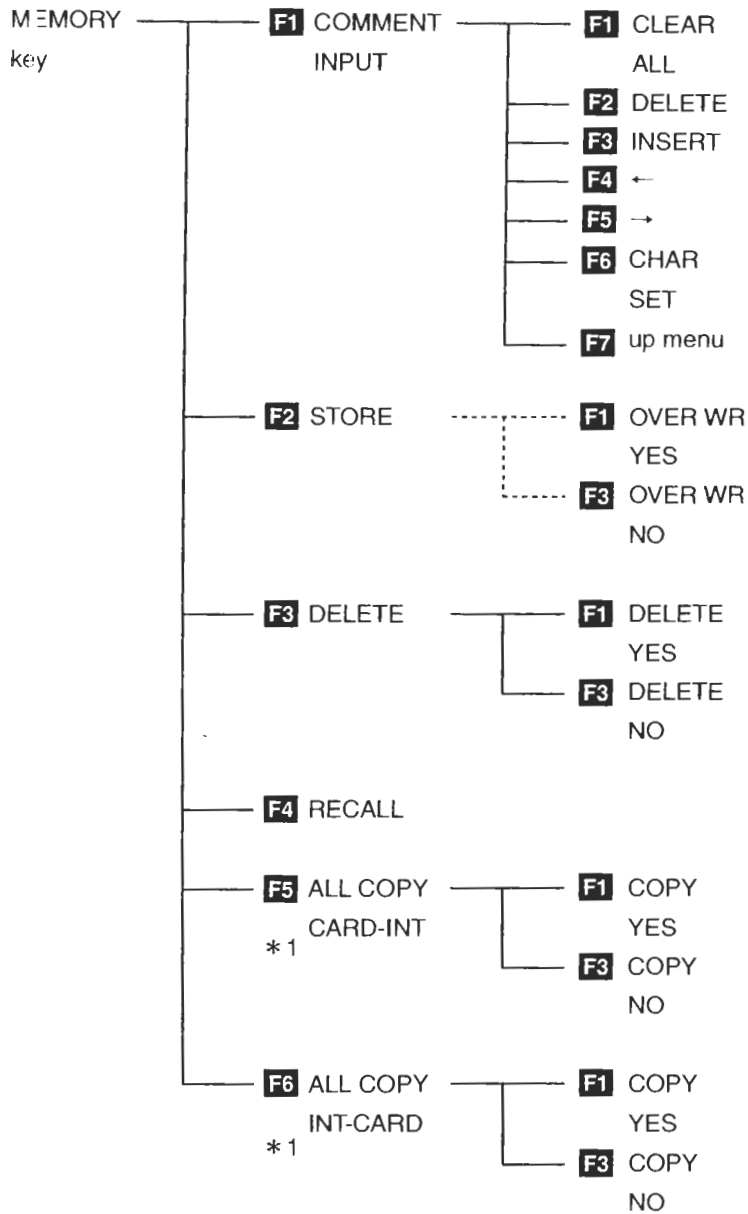

* 1 Menu shown when the Compact Flash Memory Card Unit that comes standard is inserted.

5. SYSTEM CONFIGURATION BEFORE WAVEFORM MONITORING

5.1 SDI Input Signal Selection

5.1.1 SDI Input Signal

- The SDI signal input connectors (INPUT SDI A, B) ②⑥ are dedicated to serial digital video signals.

Do not input other types of signals such as analog video signals.

- **The signal amplitude is within 800 mVp-p±10 %.** Do not apply signals that exceed this amplitude.
- Below are the supported formats. Only component SDI signals are supported; **Composite SDI signals are not supported.**
- There are two methods for setting the format. One is to detect the format automatically, and the other is to set the format manually. For details, see section 5.4, "Video Signal Format Setting."

1	1080i/60
2	1080i/59.94
3	1080i/50
4	1080p/30
5	1080p/29.97
6	1080p/25
7	1080p/24
8	1080p/23.98
9	1080PsF/30
10	1080PsF/29.97
11	1080PsF/25
12	1080PsF/24
13	1080PsF/23.98
14	720p/60
15	720p/59.94
16	525i/59.94
17	625i/50

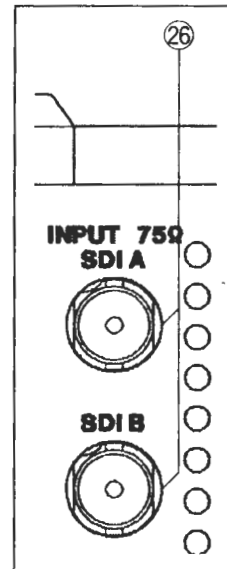

Figure 5.1 SDI signal input connectors ②⑥
(INPUT SDI A,B)

5.1.2 SDI Input Selection

The SDI signal input selection key ⑦ is switches the SDI signal input connectors (INPUT SDI A,B) ②⑥ to select the channel corresponding to the SDI input signal to be monitored on the LV 5750.

The A and B indicators to the left of the SDI signal input selection key ⑦ illuminates according to the selected channel.

If you press the SDI signal input selection key ⑦ when an error is being observed, a NO SIGNAL or ERROR message appears, and the error count is incremented.

If you switch the input signal by pressing the SDI signal input selector key (SDI) ⑦, the PHONES jack output and various displays will not appear for a few seconds.

5.2 External Synchronization Signal Setting

5.2.1 External Sync Signals

- The EXT REF connector ③② supports HDTV analog tri-level sync signals and SDTV analog black burst signals.
- The format of the signal input to the EXT REF connector ③② is automatically determined.
- **The signal amplitude is within ± 5 V.**
Do not apply signals that exceed this voltage.
- When applying HDTV tri-level sync signals, input signals that have the same frame frequency and line frequency as HD-SDI signals.
- The video signal waveform on the reference of an external synchronize signal indicates that the waveform phase of approximately 1 clock is not decided.
- If the video signal waveform is displayed using an external sync signal as reference, the waveform phase of 1 clock before and after the video signal clock is indefinite.
- Below are black burst signal formats for which the waveform display can be synchronized.

525i/59.94 black burst signal

1080i/59.94

1080p/29.97

1080PsF/29.97

1080PsF/23.98 (10 field ID is required for black burst)

1080p/23.98 (10 field ID is required for black burst)

720p/59.94

525i/59.94

625i/50 black burst signal

1080i/50

1080p/25

1080PsF/25

625i/50

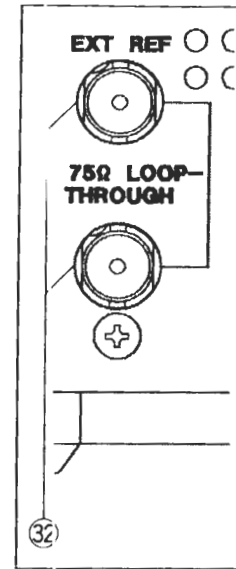

Figure 5.2 EXT REF connector ③② (EXT REF)

When an external sync signal is applied, the format of the sync signal is automatically detected.

If the 10 field ID is embedded and the SDI format is 1080PsF/23.98 or 1080p/23.98 when an NTSC black burst is applied, the 10 field ID is automatically detected.

5.2.2 External Sync Signal Switching

To display waveforms with respect to the external sync signal, press the REFERENCE key ⑥ to illuminate the EXT LED.

If the SDI signal and the external sync signal are not synchronized, the waveform display moves.

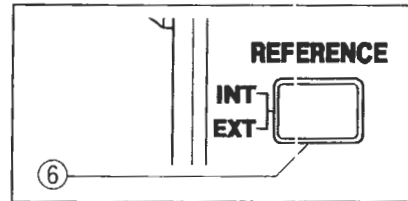

Figure 5.3 REFERENCE key ⑥

If you select INT using the REFERENCE key ⑥, the waveform is displayed using the sync signal on the SDI signal.

The displays that are affected by switching INT and EXT using the REFERENCE key ⑥ are waveform display and vectorscope display.

For picture display, audio display, and data dump display, synchronization is achieved using the SDI sync signal regardless of the INT/EXT setting.

5.3 System Menu

Settings related to the operation of the entire system are configured from the system menu by pressing the SYSTEM key ④.

Press the SYSTEM key ④ to display the System Setup Menu shown below.

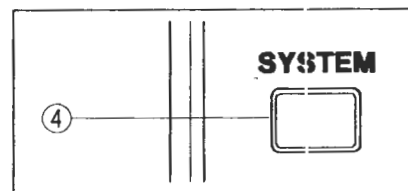

Figure 5.4 SYSTEM key ④

INTERFACE is a menu for options.

If the standard Compact Flash Memory Card Unit is installed, the interface setup menu does not appear.

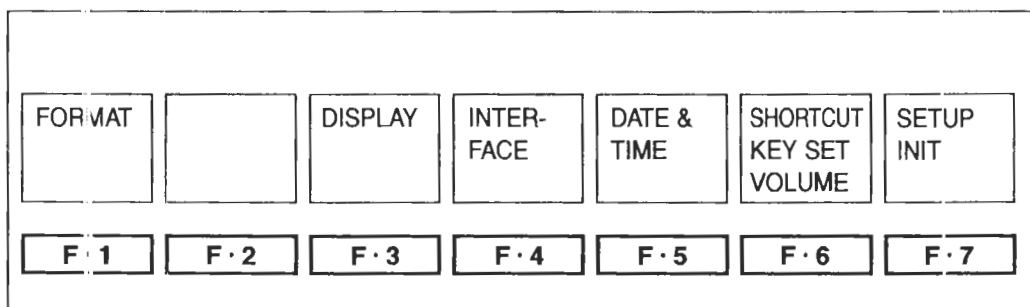

Figure 5.5 System setup menu

Function Key	Description
F.1 FORMAT	Sets the video signal format
F.3 DISPLAY	Sets the display
F.4 INTERFACE	Sets the input/output interface
F.5 DATE & TIME	Sets the date/time
F.6 SHORTCUT KEY SET	Sets the shortcut key operation
F.7 SETUP INIT	Initializes settings

Table 5.1 System setup menu description

5.4 Video Signal Format Setting

To set the video signal format, press the **[F.1]** FORMAT key from the system setup menu.

The video signal format setup menu appears. Then, set the items as desired.

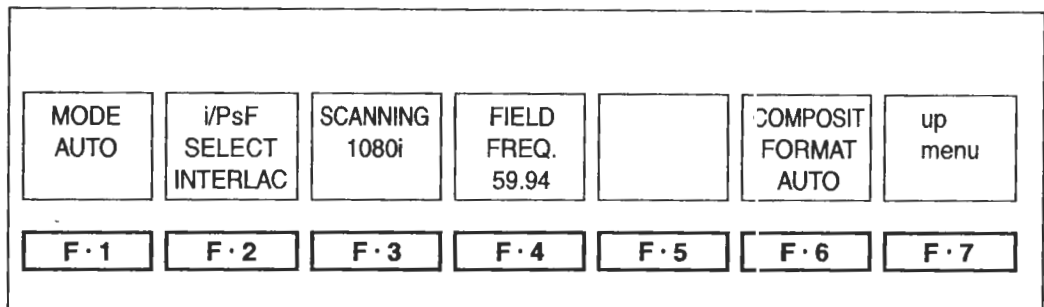

Figure 5.6 Video signal format setup menu

Function Key	Description
F.1 MODE	Selects auto/manual setting of the video signal format
F.2 i/PsF SELECT	Selects interlace and segment frame
F.3 SCANNING	Selects scanning when manual is selected
F.4 FIELD(FRAME)FREQ.	Selects the field/frame frequency when manual is selected
F.6 COMPOSIT FORMAT	Selects the format for pseudo-composite display

Table 5.2 Description of the video signal format setup menu

5.4.1 Auto/Manual Selection

You can select auto or manual setting for the SDI signal video format.

(1) Auto Selection of the Video Signal Format

[**SYSTEM**] → [**F.1**] FORMAT → [**F.1**] MODE :AUTO]

From the video signal format setup menu, press [**F.1**] MODE to select AUTO. The LV 5750 detects the format of the input SDI signal and automatically sets itself.

The detected video signal format is displayed at the upper left corner of the screen (the video signal format display must be turned ON as described in section 5.5.1, "Information Display").

*: The LV 5750 cannot automatically distinguish HD-SDI interlace and segment frame.

See section 5.4.2, "Interlace and Segment Frame Selection" and set it manually. Below are video signal formats that the LV 5750 cannot automatically distinguish.

1080i/60 and 1080PsF/30

1080i/59.94 and 1080PsF/29.97

1080i/50 and 1080PsF/25

(2) Manual Selection of the Video Signal Format

[[**SYSTEM**] → [**F.1**] FORMAT → [**F.1**] MODE :MANUAL]

If you press the [**F.1**] MODE key to select MANUAL from the video signal format setup menu, you must set the video signal format manually according to the input SDI signal.

To do so, carry out the procedures described in sections 5.4.3, "Scanning Selection," and 5.4.4, "Field/Frame Frequency Selection" in order. If the scanning and field/frame frequency selections are not correct, disturbance will occur on the display.

When an SDI signal of the specified video signal format is received, the video signal format is displayed at the upper left corner of the screen (the video signal format display must be turned ON as described in section 5.5.1, "Information Display").

5.4.2 Interlace and Segment Frame Selection

[[**SYSTEM**] → [**F.1**] FORMAT → [**F.2**] i/PsF SELECT :INTERLAC / SEG.FRM]

Even when auto setting of the video signal format is used, 1080i (interlace) and 1080PsF (segment frame) cannot be distinguished automatically. You must manually select interlace or segment frame.

Press the [**F.2**] i/PSF SELECT key from the video signal format setup menu and select interlace or segment frame. This selection is possible only when AUTO is selected in section 5.4.1, "Auto/Manual Setting Selection." The menu does not appear when MANUAL is selected.

INTERLAC: Selects interlace.

SEG.FRM: Selects segment frame.

5.4.3 Scanning Selection

[**SYSTEM**] → [**F.1**] FORMAT → [**F.3**] SCANNING :1080i / 1080PsF / 1080p / 720p / 525i / 625i]

Manually selects the scanning of the video signal format (as a video signal format setting).

The scanning selection is possible only when MANUAL is selected in section 5.4.1, "Auto/Manual Setting Selection." The menu does not appear when AUTO is selected.

- 1080i: Selects HD-SDI with 1080 active interlaced lines.
- 1080PsF: Selects HD-SDI with 1080 active segment frames.
- 1080p: Selects HD-SDI with 1080 active progressive lines.
- 720p: Selects HD-SDI with 720 active progressive lines.
- 525i: Selects SD-SDI with 525 interlaced lines.
- 625i: Selects SD-SDI with 625 interlaced lines.

5.4.4 Field/Frame Frequency Selection

[**SYSTEM**] → [**F.1**] FORMAT → [**F.4**] FIELD FREQ. :60 / 59.94 / 50]

[**SYSTEM**] → [**F.1**] FORMAT → [**F.4**] FRAME FREQ. :30 / 29.97 / 25 / 24 / 23.98]

[**SYSTEM**] → [**F.1**] FORMAT → [**F.4**] FRAME FREQ. :30 / 29.97 / 25 / 24 / 23.98]

[**SYSTEM**] → [**F.1**] FORMAT → [**F.4**] FRAME FREQ. :60 / 59.94

Manually selects field frequency or frame frequency as a video signal format setting.

The selectable field/frame frequencies vary depending on the selection made in section 5.4.3, "Scanning Selection" (among the video signal formats that the LV 5750 supports).

The selected value is displayed as video signal format at the upper right corner of the screen (the video signal format display must be turned ON as described in section 5.5.1, "Information Display").

The field/frame frequency selection is possible only when MANUAL is selected in section 5.4.1, "Auto/Manual Setting Selection." The menu does not appear when AUTO is selected.

Below are the selectable ranges of the field/frame frequency with respect to the item selected in section 5.4.3, "Scanning Selection." The field frequency is fixed when 525i or 625i is selected.

		Field Frequency	Frame Frequency
Scanning Selection	1080i	60 / 59.94 / 50	—————
	1080PsF	—————	30 / 29.97 / 25 / 24 / 23.98
	1080p	—————	30 / 29.97 / 25 / 24 / 23.98
	720p	—————	60 / 59.94
	525i	59.94	—————
	625i	50	—————

Table 5.3 Field/Frame frequencies according to the scanning selection

5.4.5 Format Selection of the Pseudo-Composite Display

[SYSTEM] → [F.1] FORMAT → [F.6] COMPOSIT FORMAT :AUTO / NTSC / PAL]

When pseudo-composite display is selected, you can select whether to display it in NTSC or PAL. You can also select auto setting. In auto setting, PAL is used only when the frame rate or field rate is 25 Hz or 50 Hz. For all other cases, NTSC is used.

Press the [F.6] COMPOSIT FORMAT key from the video signal format setup menu to make the selection.

NTSC: Artificially converts all video signal formats into NTSC composite signal.

PAL: Artificially converts all video signal formats into PAL composite signal.

AUTO: Artificially converts video signal formats with frame/field rate of 25 Hz or 50 Hz into PAL and all other video signal formats into NTSC composite signal.

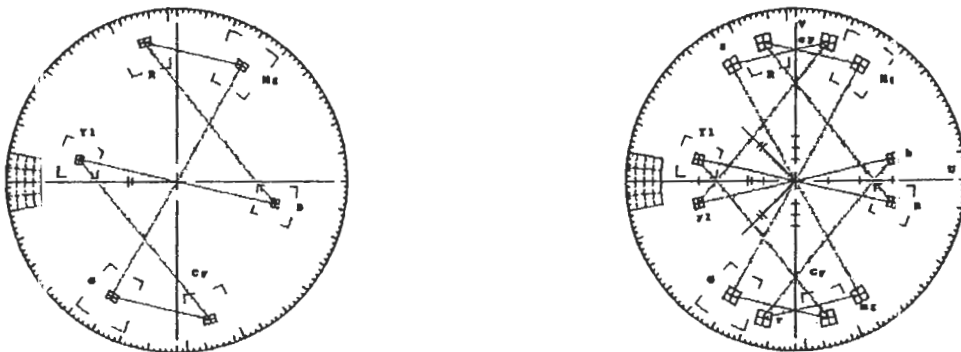

Figure 5.7 NTSC and PAL when displaying pseudo-composite vector waveforms

5.5 Screen Display Settings

To set the screen display, press the [F.3] DISPLAY key from the system menu.

The screen display setup menu appears. Then, set the items as desired.

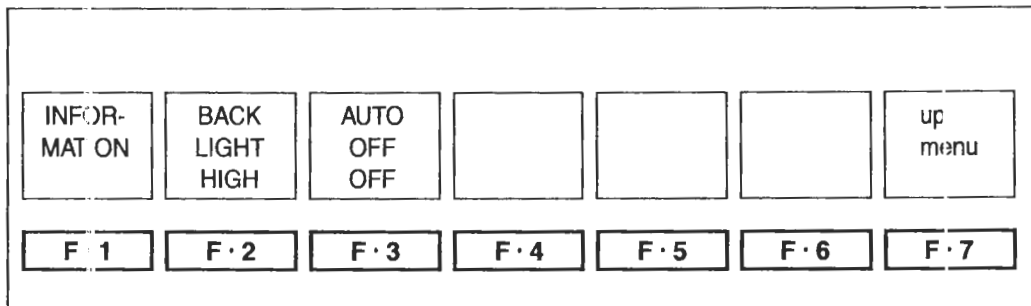

Figure 5.8 Screen display setup menu

Function Key	Description
F.1 INFORMATION	Sets the information display at the upper of the screen
F.2 BACK LIGHT	Selects the brightness of the LCD backlight
F.3 AUTO OFF	Selects the auto shutoff function of the LCD backlight

Table 5.4 Description of the screen display setup menu

5.5.1 Information Display

The LV 5750 can display information such as the video signal format and date/time at the top section of the screen. You can use the menu to turn on or off the function.

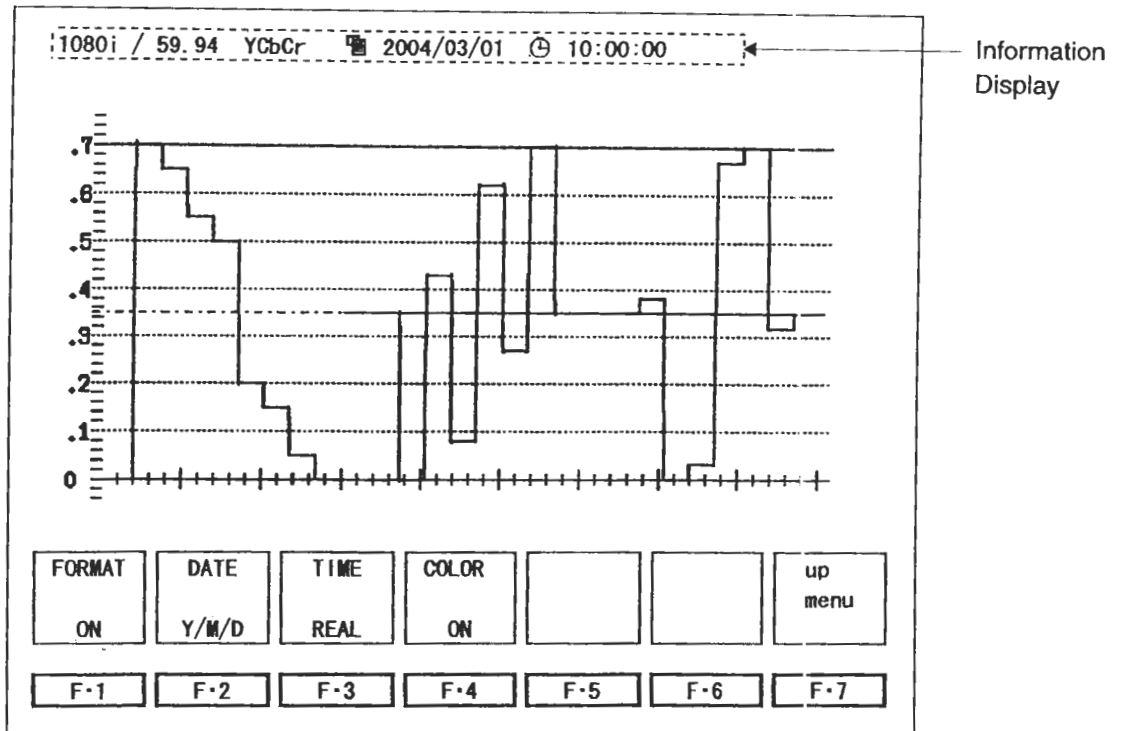

Figure 5.9 Information Display

(1) Showing the Video Signal Format

[**SYSTEM**] → [**F-3**] DISPLAY → [**F-1**] INFORMATION → [**F-1**] FORMAT :ON/
OFF]

From the information display menu, press [**F-1**] FORMAT to select whether to show the video signal format at the top section of the screen.

(2) Showing the Date

[**SYSTEM**] → [**F-3**] DISPLAY → [**F-1**] INFORMATION → [**F-2**] DATE :Y/M/D
/ M/D/Y / D/M/Y / OFF]

From the information display menu, press [**F-2**] DATE to select the format of the date to be displayed at the top section of the screen.

Y/M/D: Displayed in the order year, month, and day.

M/D/Y: Displayed in the order month, day, and year.

D/M/Y: Displayed in the order day, month, and year.

OFF: Does not show the date.

(3) Displaying the Time

[**SYSTEM**] → [**F.3**] DISPLAY → [**F.1**] INFORMATION → [**F.3**] TIME: REAL / OFF]

From the information display menu, press the [**F.3**] TIME key to select the format of the time to be displayed at the top section of the screen.

REAL: Displays the current time (built-in realtime clock)

OFF: Does not show the time.

(4) Showing the Color System

[**SYSTEM**] → [**F.3**] DISPLAY → [**F.1**] INFORMATION → [**F.4**] COLOR :ON/OFF]

From the information display menu, press [**F.4**] COLOR to select whether to show the color system at the top section of the screen.

The color system is displayed as follows when ON is selected.

YCbCr: Displaying the waveform using Y, C_B, C_R signal

GBR: Converting to G, B, R signal and displaying the waveform

RGB: Converting to R, G, B signal and displaying the waveform

COMP: Converting to pseudo-composite signal and displaying the waveform

5.5.2 Backlight Switching

You can adjust the brightness of the LCD backlight and select auto shutoff.

(1) Adjusting the Brightness of the Backlight

[**SYSTEM**] → [**F.3**] DISPLAY → [**F.2**] BACK LIGHT :HIGH/LOW]

From the screen display menu, press [**F.2**] BACK LIGHT to adjust the brightness of the LCD. Select HIGH to brighten, LOW to dim.

(2) Auto Shutoff

[[**SYSTEM**] → [**F.3**] DISPLAY → [**F.3**] AUTO OFF :OFF / 5 min / 30 min / 60 min]

From the screen display menu, press [**F.3**] AUTO OFF to set the auto shutoff function of the LCD backlight.

OFF: Does not automatically shut off the backlight.

5 min: The backlight is shut off 5 minutes after pressing the last key.

30 min: The backlight is shut off 30 minutes after pressing the last key.

60 min: The backlight is shut off 60 minutes after pressing the last key.

To recover from the backlight off condition, press any key.

The backlight turns ON, and the screen returns to the original condition.

Note Allow the backlight to turn off and on only a few times per day.
Repeating the action frequently shortens the backlight life.

5.6 Interface Setting

If the optional Remote Control Unit or Ethernet Unit is installed, you must enter the remote connector or Ethernet connector interface settings. Enter these settings by selecting [F.4] INTERFACE from the system menu.

If the standard Compact Flash Memory Card Unit is installed, the interface setup menu does not appear.

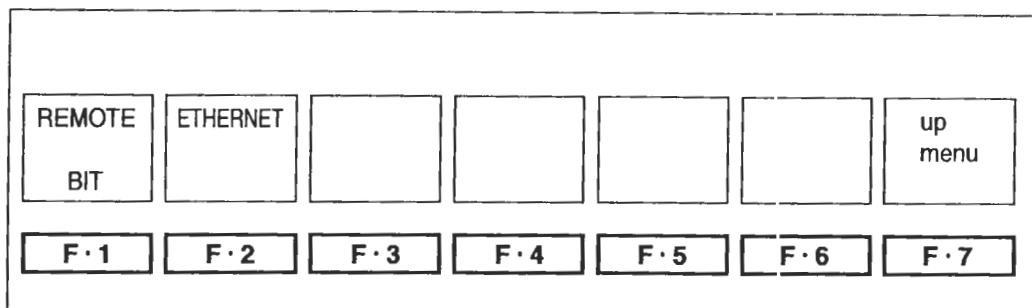

Figure 5.10 Interface setup menu

Function Key	Description
F.1 REMOTE	Selects the preset recall from the remote connector on the rear panel.
F.2 ETHERNET	Sets the Ethernet parameters.

Table 5.5 Description of the interface setup menu

5.6.1 Recalling Presets through the REMOTE Connector

[SYSTEM] → [F.4] INTERFACE → [F.1] REMOTE : BIT / BINARY]

If you install the Remote Control Unit that is sold separately, you will be able to recall preset information using remote control. The remote connector has 8 pins assigned for recalling presets.

Select BIT when using the 8 pins to recall up to 8 presets. Select BINARY when using the lower 5 pins to recall up to 30 presets using binary code.

For details, see the "LV 5750-02 Instruction Manual".

5.6.2 Ethernet Settings

[SYSTEM] → [F.4] INTERFACE → [F.2] ETHERNET]

You can set the Ethernet Unit that is sold separately by pressing [F.2] ETHERNET from the interface setup menu.

For details, see the "LV 5750-01 Instruction Manual".

5.7 Date and Time Settings

The LV 5750 has a calendar and time function. Thus, date/time can be displayed and error logs can be taken with time information. For details on displaying the date/time, see section 5.5, "Screen Display Settings." For details on error logging, see section 11.2, "Event Log".

YEAR 1999	MONTH 1	DAY 1	HOUR 0	MINUTE 0	SECOND 0	CLOCK SET
F·1	F·2	F·3	F·4	F·5	F·6	F·7

Figure 5.11 Date and Time Setup Menu

(1) Adjusting the Year

[[SYSTEM] → [F·5] DATE & TIME → [F·1] YEAR]

You can set the year from 1900 to 2200. From the menu, select [F·1] YEAR and then adjust the year using the function dial ([F·D]) ①9.

(2) Adjusting the Month

[[SYSTEM] → [F·5] DATE & TIME → [F·2] MONTH]

You can set the month from January to December. From the menu, select [F·2] MONTH and then adjust the month using the function dial ([F·D]) ①9.

(3) Adjusting the Date

[[SYSTEM] → [F·5] DATE & TIME → [F·3] DAY]

You can set the date from 1st to 31st. From the menu, select [F·3] DAY and then adjust the date using the function dial ([F·D]) ①9.

(4) Adjusting the Hour

[[SYSTEM] → [F·5] DATE & TIME → [F·4] HOUR]

You can set the hour from 1 to 24. From the menu, select [F·4] HOUR and then adjust the hour using the function dial ([F·D]) ①9.

(5) Adjusting the Minute

[[SYSTEM] → [F·5] DATE & TIME → [F·5] MINUTE]

You can set the minute from 0 to 59. From the menu, select [F·5] MINUTE and then adjust the minute using the function dial ([F·D]) ①9.

(6) Adjusting the Second

[[SYSTEM] → [F·5] DATE & TIME → [F·6] SECOND]

You can set the second from 0 to 59. From the menu, select [F·6] SECOND and then adjust the second using the function dial ([F·D]) ①9.

(7) Date/Time Confirmation

[**SYSTEM**] → [**F.5**] DATE & TIME → [**F.7**] CLOCK SET]

When you are done adjusting the date and time, press [**F.7**] CLOCK SET to write to the calendar function of the LV 5750.

The date/time setup menu is closed as the date/time is written, and the screen returns to the system menu.

To cancel the writing, press the SYSTEM key ④.

5.8 Shortcut Key Setting

[**SYSTEM**] → [**F.6**] SHORTCUT KEY SET : KEY LED / DIRECT_K / VOLUME]

You can assign three of the available functions to the SHORTCUT key ⑳.

From the system setup menu, press the [**F.6**] SHORTCUT KEY SET key. Assign the function on the shortcut key setup menu that appears.

(1) Illumination of All Key LEDs

By assigning the key LED illumination function to the SHORTCUT key ⑳, you can illuminate all the key LEDs of the LV 5750 using the SHORTCUT key. When you perform the next operation, all keys other than the functioning key are turned OFF.

From the short cut key setup menu, press [**F.6**] SHORTCUT KEY SET to select KEY LED. The shortcut key is assigned to the key LED illumination function.

(2) Direct Recall

By assigning the direct recall function to the SHORTCUT key ⑳, you can recall presettings using the SHORTCUT key.

Direct recall is useful when a setting that is used often but deep in the menu tree is assigned (event log screen or data dump display, for example).

From the short cut key setup menu, press [**F.6**] SHORTCUT KEY SET to select DIRECT_K. The shortcut key is assigned to the direct recall function.

The preset procedure is as follows:

- Set the LV 5750 in a condition you wish to assign to the direct recall function.
- Press the MEMORY key ③ to display the preset memory menu.
- Press the SHORTCUT key ⑳. The key LED blinks twice, and the setting is registered.

You are done assigning the direct recall function.

(3) PHONES jack volume adjustment

By assigning the volume adjustment function to the SHORTCUT key ⑩, you will be able to adjust the PHONES jack volume using the function dial (F·D) ⑨ by pressing the SHORTCUT key regardless of the menu that is being displayed.

To assign the function, select VOLUME using the (F·6) SHORTCUT KEY SET from the system menu. This will make the function dial (F·D) ⑨ the PHONES jack volume adjustment dial when the SHORTCUT key is pressed.

The volume adjustment function is cleared when another key is pressed.

Use the AUDIO menu for normal volume adjustment.

5.9 Initialization

The LV 5750 stores the last operation before the power is turned off, and starts with the previous condition when the power is turned on the next time.

(1) Normal Initialization Procedure

[(SYSTEM) → (F·7) SETUP INIT → (F·1) INIT YES]

[(SYSTEM) → (F·7) SETUP INIT → (F·3) INIT CANCEL]

Press the SYSTEM key ④, (F·7) SETUP INIT, and then (F·1) INIT YES. Press (F·3) INIT CANCEL to return to the system setup menu without initializing.

This initialization procedure does not initialize the Ethernet settings such as the IP address or the presets.

(2) Hardware Reset

To clear the backup memory and clear all settings including the Ethernet settings and presets, you must carry out a hardware reset.

To carry out a hardware reset, turn ON the power while holding down the V POS control ⑨ and the H POS control ⑪.

When you carry out a hardware reset, a message appears stating that the backup memory has been cleared. Press any key. The initialization procedure terminates.

* The Ethernet Unit is sold separately.

6. VIDEO SIGNAL WAVEFORM DISPLAY

6.1 Video Signal Waveform Display

Press the WFM key ⑬ to display video signal waveforms.

The screen shows the video signal waveform, scale, and waveform display menu.

The waveform display menu consists of two pages. Use [F.7] next menu or prev menu to switch between page 1 and 2.

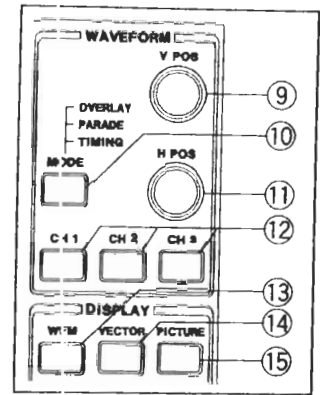
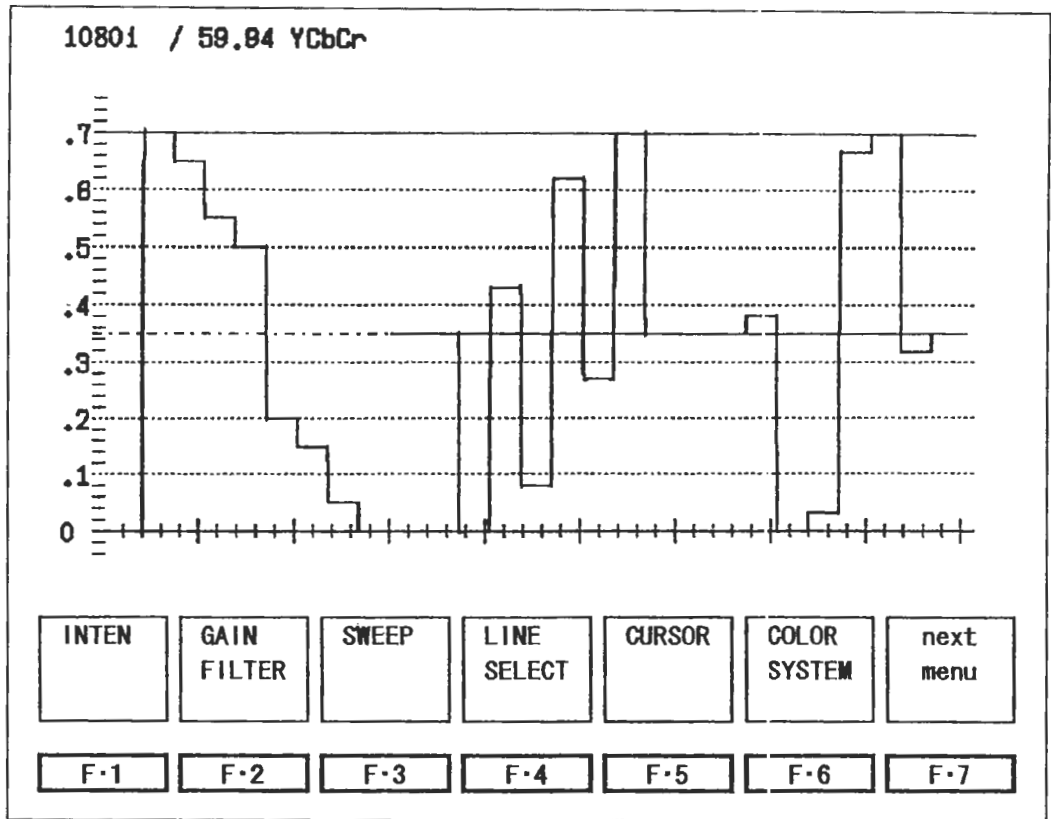
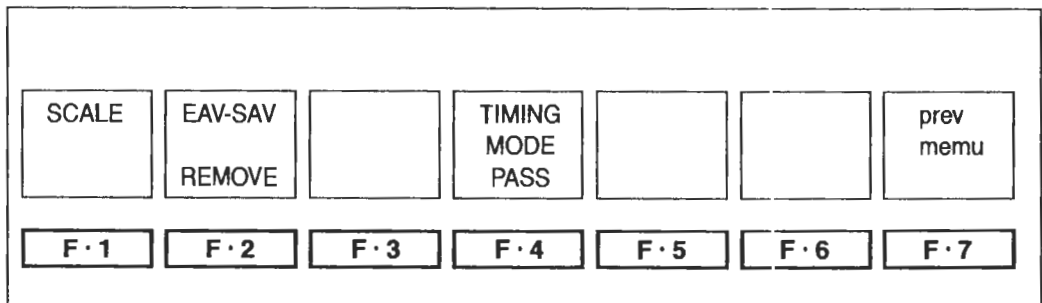

Figure 6.1 Waveform display setup key ⑬



(a) Page 1



(b) Page 2

Figure 6.2 Waveform Display and Waveform Display Menu

Function Key	Description
F-1 INTEN	Adjusts the intensity of the displayed waveform
F-2 GAIN FILTER	Sets the gain and low-pass filter
F-3 SWEEP	Sets the sweep time
F-4 LINE SELECT	Line select
F-5 CURSOR	Cursor measurement
F-6 COLOR SYSTEM	Sets the color system
F-1 SCALE	Sets the size and unit of the scale
F-2 EAV-SAV	Selects the waveform display of the blanking period
F-4 TIMING MODE	Selects the timing display

Table 6.1 Description of the waveform display menu

6.2 Display Channel Settings

Use the CH1, CH2, and CH3 keys ⑫ to select the waveform you wish to display. Signals assigned to CH1, CH2, and CH3 keys ⑫ depend on whether Y, C_B, C_R display, G, B, R display, or R, G, B display is used.

For details, see section 6.10.1, "Color Matrix Conversion."

By default, CH1, CH2, and CH3 are assigned to Y, C_B, and C_R, respectively.

Press the CH1, CH2, or CH3 key ⑫ to illuminate the corresponding LED and display the waveform assigned to that key. Press the key again to turn the LED off and clear the waveform display.

However, you cannot turn off all the channels.

If you select TIMING display using the MODE key ⑩, the conditions of the CH1, CH2, and CH3 keys ⑫ are ignored, and timing display is activated. In addition, the CH1, CH2, and CH3 keys ⑫ do not affect displays other than waveform displays such as vectorscope display and picture display.

The CH1, CH2, CH3 keys ⑫ do not function when the pseudo-composite display is selected as described in section 6.10.1, "Color Matrix Conversion."

6.3 Display Mode Settings

Press the MODE key ⑩ to switch the waveform display format between overlay, parade, and timing (time difference measurement).

If the timing display is prohibited (PASS) as described in section 6.13, "Mode Key Switching," the timing display does not appear even when you press the MODE key ⑩.

If the pseudo-composite display is selected as described in section 6.10.1, "Color Matrix Conversion," the display does not change even when you press the MODE key ⑩.

6.3.1 Overlay Display

Select OVERLAY using the MODE key $\text{\textcircled{10}}$ to display the waveforms of CH1, CH2, and CH3 overlaid.

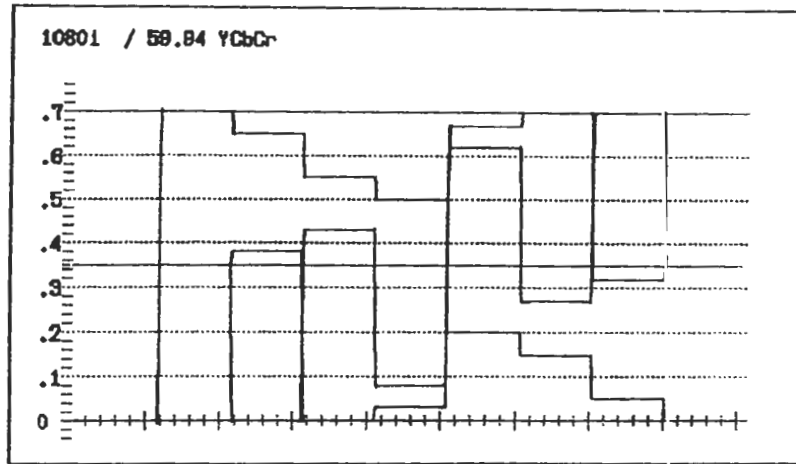

Figure 6.3 Overlay Display

6.3.2 Parade Display

Select PARADE using the MODE key $\text{\textcircled{10}}$ to display the waveforms of CH1, CH2, and CH3 side by side.

The waveforms are displayed in the order CH1, CH2, and CH3 from the left. In addition, if you select PARADE, the screen is automatically set to 1H or 1V display even if 2H display or 2V display is selected as described in section 6.7, "Sweep Settings." 2H display or 2V display is not possible in parade display.

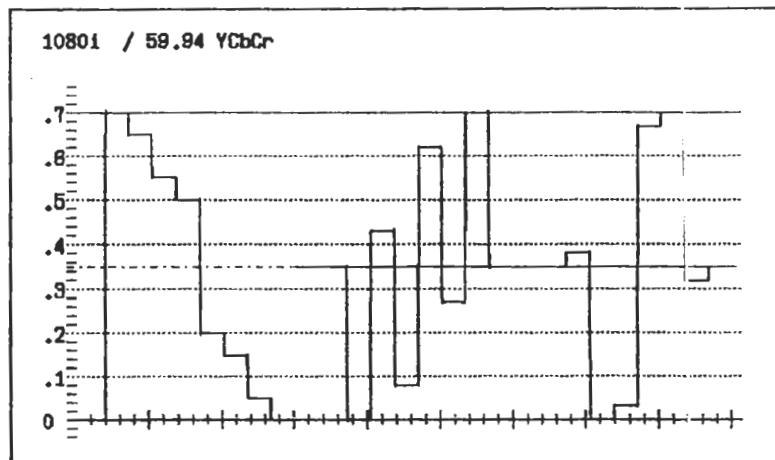

Figure 6.4 Parade Display

6.3.3 Timing Display

Select **TIMING** using the **MODE** key ⑩ to measure the time and amplitude differences between channels with respect to CH1 (Y/G). A bowtie signal is used as a signal source.

Timing display shows two bowtie displays side by side as shown in Figure 6.5. The conditions of CH1, CH2, and CH3 ⑫ are ignored.

If the timing display is prohibited as described in section 6.13, "Mode Key Switching," the timing display does not appear even when you press the **MODE** key ⑩.

By default, the timing display is prohibited.

* Bowtie signal waveform measurement

If you set the LV 5750 to **TIMING** display, CH1 (Y/G) and CH2 (C_B/B) are displayed on the left and CH1 (Y/G) and CH3 (C_R/R) are displayed on the right. The vertical lines of bowtie signals are marker signals. The long marker at the center is the reference marker (no time difference).

The interval between markers represents a timing difference of 1 ns (when Leader's LT 443D is used). The timing difference is read from the interval between the null and the reference marker. If the null is positioned to the left of the reference marker, this indicates that C_B/B or C_R/R is advanced relative to Y/G.

If there is an amplitude difference between channels, the depth of the null is decreased.

(Bowtie signal: use authorized by Tektronix, Inc.)

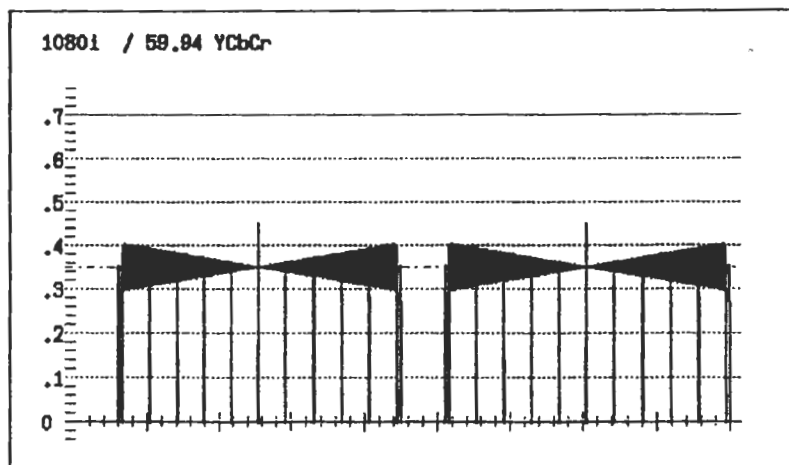

Figure 6.5 Timing Display

6.4 Position Adjustment

You can adjust the vertical position of the video signal waveform on the screen using the **V POS** control ⑨ and the horizontal position using the **H POS** control ⑪.

The **V POS** control ⑨ and **H POS** control ⑪ also function as switches. Press the switch to reset the display position of the video signal waveform to the reference position.

6.5 Brightness Adjustment

To adjust the brightness of the video signal waveform or the scale, press the WFM key ⑬ to display the waveform display menu. Then, select [F.1] INTEN. The brightness adjustment menu appears. Set the items as desired.

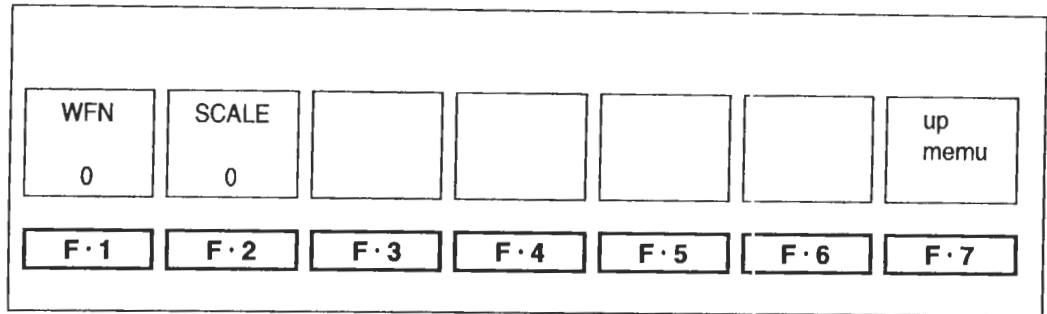

Figure 6.6 Brightness Adjustment Menu

6.5.1 Brightness Adjustment of the Video Signal Waveform

[[WFM] → [F.1] INTEN → [F.1] WFM → [F.D]]

To adjust the intensity (brightness) of the video signal waveform, press [F.1] INTEN from the brightness adjustment menu.

While the [F.1] WFM section is selected in blue, turn the function dial ([F.D]) ⑰ to adjust the brightness between -128 and 127.

The function dial ([F.D]) ⑰ also functions as a switch. Press the switch to reset the brightness of the video signal waveform to the reference value (0).

6.5.2 Scale Brightness Adjustment

[[WFM] → [F.1] INTEN → [F.2] SCALE INTEN → [F.D]]

To adjust the brightness of the scale on the video signal waveform display, press [F.2] SCALE INTEN from the brightness adjustment menu and turn the function dial ([F.D]) ⑰.

The adjustment range of the scale brightness is -8 to 7 (16 levels).

The function dial ([F.D]) ⑰ also functions as a switch. Press the switch to reset the brightness of the scale on the video signal waveform display to the reference value (4).

6.6 Gain/Filter Adjustment

To adjust the gain (amplitude) of the video signal waveform or set the filter, press the WFM key (13) to display the waveform display menu. Then, select [F.2] GAIN FILTER. The gain/filter adjustment menu appears. Set the items as desired.

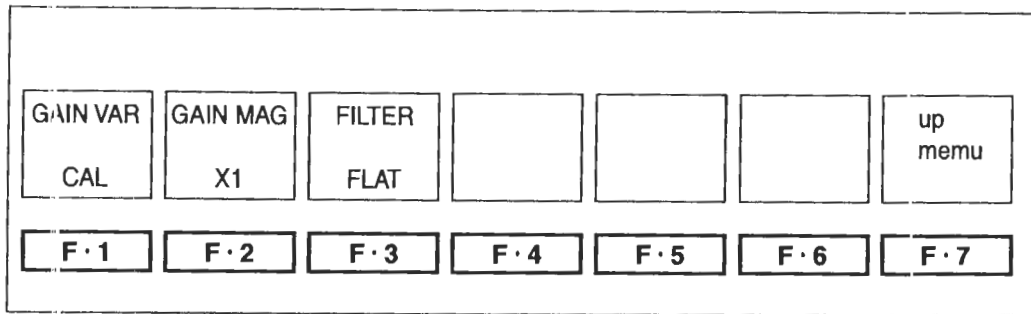

Figure 6.7 Gain/Filter Adjustment Menu

6.6.1 Gain Adjustment

[WFM] → [F.2] GAIN FILTER → [F.1] GAIN VAR :CAL / VAR]

To continuously change the gain of the video signal waveform, press [F.1] GAIN VAR from the gain/filter adjustment menu. Turn the function dial ([F.D]) (19) with VAR selected to change the gain continuously. Select CAL to set the gain to the reference value.

The gain adjustment range is x0.20 to x2.00 with respect to the reference gain.

CAL: Reference gain

VAR: Continuous change of gain (variable)

The function dial ([F.D]) (19) also functions as a switch. Press the switch while VAR is selected to reset the gain to the reference value.

The gain reference is set to the value selected in section 6.6.2, "Gain Selection."

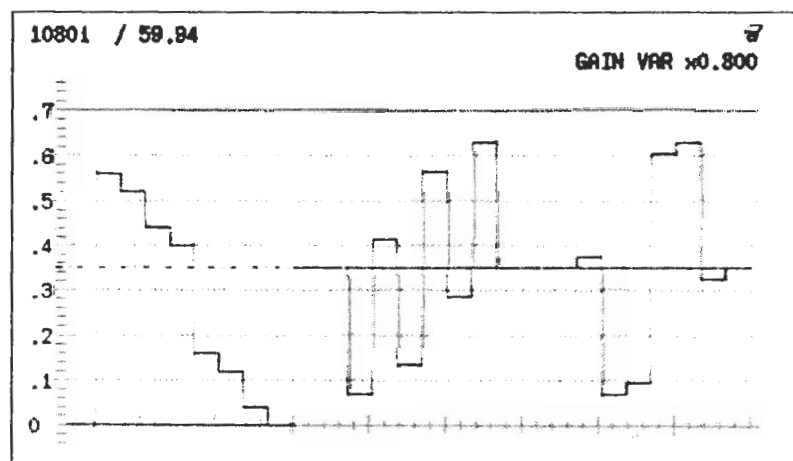

Figure 6.8 Variable Gain Display

6.6.2 Gain Selection

[WFM] → [F.2] GAIN FILTER → [F.2] GAIN MAG → X1 / X5]

To change the gain of the video signal waveform to 1x or 5x, press [F.2] MAG from the gain/filter adjustment menu. Select X5 to set the gain to 5x. Select X1 to set the gain to the reference value (1x).

X1: 1x gain

X5: 5x gain

6.6.3 Filter Selection

(1) Filter Selection on the Component Display

[WFM] → [F.2] GAIN FILTER → [F.3] FILTER → FLAT / LOW PASS]

To apply a low-pass filter on the component waveform display such as Y, C_B, C_R or G, B, R, press the [F.3] FILTER key from the gain/filter adjustment menu. Select LOW PASS to apply a low-pass filter to the video signal waveform display. Select FLAT to produce a flat frequency response within the frequency range. The low-pass filter response is as shown in Table 6.2.

FLAT: Flat frequency response within the signal frequency range

LOW PASS: Low-pass filter response with the frequency response shown in the table below

	Frequency Range	Low-Pass Filter Response
HDTV	30 MHz	Attenuation of 20 dB or more at 20 MHz
SDTV	5.75 MHz	Attenuation of 20 dB or more at 3.8 MHz

Table 6.2 Filter Response

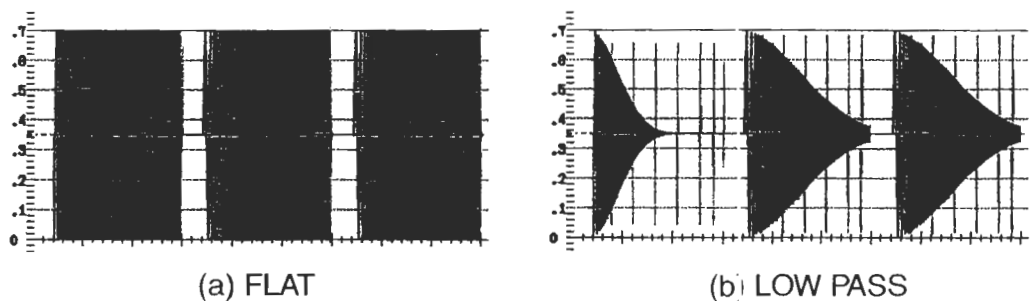
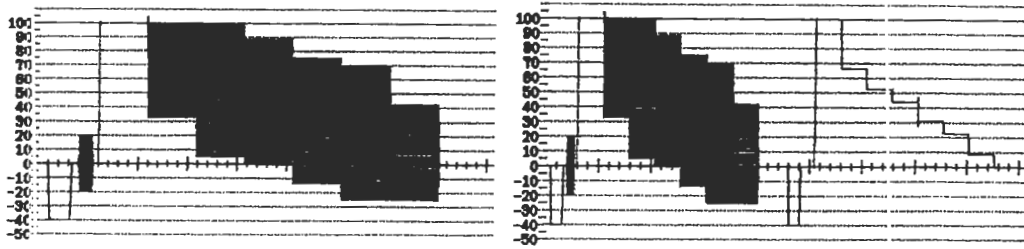

Figure 6.9 Low-pass Filter Waveform

(2) Filter Selection on the Pseudo-Component Display

[WFM] → [F.2] GAIN FILTER → [F.3] FILTER → FLAT / FLAT+LUM]

If the pseudo-composite display is selected as described in section 6.10.1, "Color Matrix Conversion," the pseudo-composite waveform and luminosity component waveform can be displayed side by side. Press the [F.3] FILTER from the gain/filter adjustment menu and select FLAT to display only the pseudo-composite waveform. Select FLAT+LUM to display the composite waveform and luminosity component using parade display.



(a) FLAT

(b) FLAT+LUM

Figure 6.10 Filter Waveform of the Pseudo-composite Display

6.7 Sweep Settings

To set a sweep on the video signal waveform, select [F.1] SWEEP from the waveform display menu that appears when you press the WFM key ⑬.

The sweep setup menu appears. Select the appropriate items. The contents of the sweep setup menu vary depending on the video signal format.

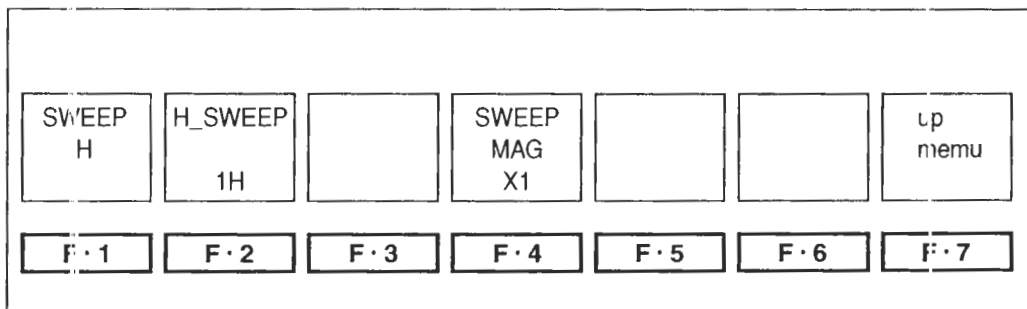

Figure 6.11 Sweep Setup Menu

6.7.1 Sweep Selection

[WFM] → [F.3] SWEEP → [F.1] SWEEP : H / V]

To switch the line display or field display (for interlace format) or frame display (for progressive format) on the video signal waveform display, press [F.1] SWEEP from the sweep setup menu.

H: Line display

V: Field display for interlace and segment frame
Frame display for progressive

6.7.2 H Sweep Selection

[WFM] → [F.3] SWEEP → [F.2] H_SWEEP : 1H / 2H]

If H (line display) is selected in section 6.7.1, "Sweep Selection," you can select 1H display, which sets the sweep time to 1 line, or 2H display, which sets the sweep time to 2 lines. However, 2H display is valid only when OVERLAY is selected using the MODE key ⑩. If PARADE is selected, the display is set to 1H.

In addition, the sweep setting for bowtie signal monitoring is enabled if TIMING is selected using the MODE key ⑩ regardless of the H sweep selection.

To switch the 1H/2H display, press **[F.2]** H_SWEEP from the sweep setup menu.

1H: 1 line display

2H: 2 line display (valid only when OVERLAY is selected as described in section 6.3, "Display Mode Settings")

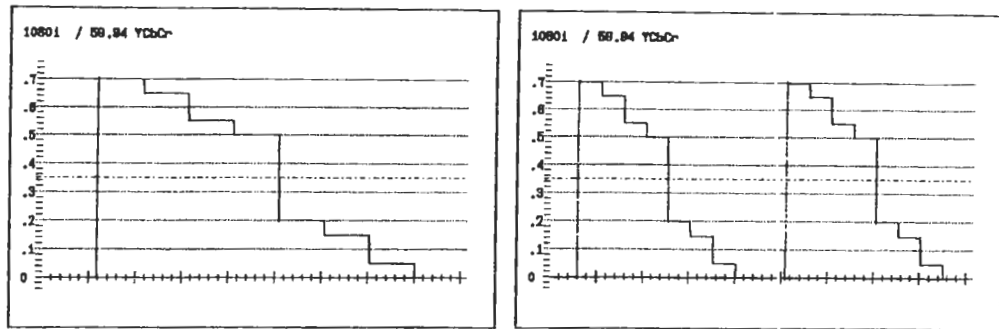

(a) 1H Display

(b) 2H Display

Figure 6.12 H Sweep Selection

6.7.3 V Sweep Selection

[**[WFM]** → **[F.3]** SWEEP → **[F.2]** V_SWEEP : 1V / 2V]

If V (field/frame display) is selected in section 6.7.1, "Sweep Selection," you can select 1V display, which sets the sweep time to 1 field, or 2V display, which sets the sweep time to 2 fields.

The V sweep selection is displayed only when the video signal format is interlace or segment frame; it is not displayed for progressive format.

In addition, 2V display is valid only when OVERLAY is selected using the MODE key **⓫**. If PARADE is selected, the display is set to 1V. The sweep setting for bowtie signal monitoring is enabled if TIMING is selected using the MODE key **⓫** regardless of the V sweep selection.

To switch the 1V/2V display, press **[F.2]** V_SWEEP from the sweep setup menu.

1V: 1 field display

2V: 2 field display (valid only when OVERLAY is selected as described in section 6.3, "Display Mode Settings")

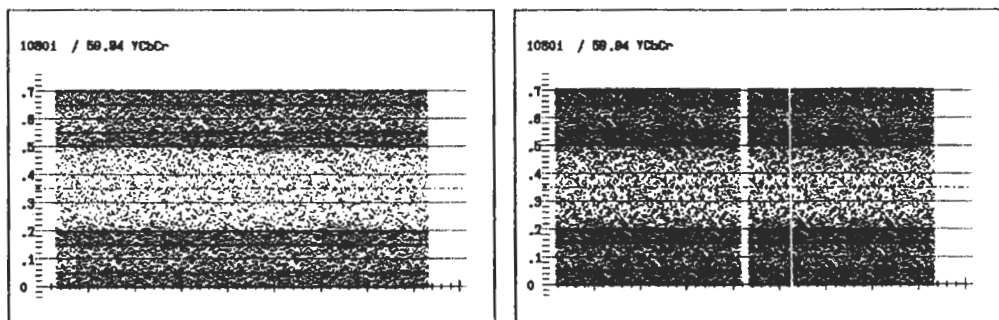

(a) 1V Display

(b) 2V Display

Figure 6.13 V Sweep Selection

6.7.4 Field Selection

[**WFM**] → [**F-3**] SWEEP → [**F-3**] FIELD :FIELD1 / FIELD2]

You can select the displayed field, if 1V is selected in section 6.7.3, "V Sweep Selection."

From the sweep setup menu, press [**F-3**] FIELD to select FIELD 1 or FIELD 2.

FIELD1: Field 1 is displayed.

FIELD2: Field 2 is displayed.

You cannot select the field if the video format is progressive.

6.7.5 Sweep Magnification

[**WFM**] → [**F-3**] SWEEP → [**F-4**] MAG :X1 / X10 / X20 / X40 / ACTIVE / BLANK]

To expand the horizontal axis of the video signal waveform display, press [**F-4**] MAG from the sweep setup menu and select sweep magnification.

You can select the following magnification settings when H is selected as described in section 6.7.1, "Sweep Selection."

x1: Turns off sweep magnification.

x10: Magnifies the sweep 10x.

x20: Magnifies the sweep 20x.

ACTIVE: Displays only the active picture area.

BLANK: Displays the line blanking period without masking.

You can select the following magnification settings when OVERLAY is selected as described in section 6.3, "Display Mode Settings" and 2H is selected as described in section 6.7.2, "H Sweep Selection."

x1: Turns off sweep magnification.

x10: Magnifies the sweep 10x.

x20: Magnifies the sweep 20x.

BLANK: Displays the line blanking period.

If BLANK is selected, the waveform of the data in the blanking period is displayed regardless of whether EAV-SAV is to PASS/REMOVE as described in section 6.12, "Blanking Display Settings."

You can select the following sweep magnification settings when V Sweep is selected in section 6.7.1, "Sweep Selection."

x1: Turns off sweep magnification.

x20: Magnifies the sweep 20x.

x40: Magnifies the sweep 40x.

Sweep Selection	Sweep Magnification					
	X1	X10	X20	X40	ACTIVE	BLANK
1H	Yes	Yes	Yes	No	Yes	Yes
2H	Yes	Yes	Yes	No	No	Yes
1V	Yes	No	Yes	Yes	No	No
2V	Yes	No	Yes	Yes	No	No

Yes indicates that it is selectable; No indicates that it is not.

However, 2V display in the progressive format cannot be selected.

Table 6.3 Relationship between Sweep Selection and Sweep Magnification

If the pseudo-composite display is selected as described in section 6.10.1, "Color Matrix Conversion," magnification settings of x10 and BLANK are not possible on 1H display and 2H display.

6.8 Line Selector

To select a line on the video signal waveform to be displayed, press the WFM key $\text{\textcircled{13}}$ to display the waveform display menu. Then, select $\text{\textcircled{F.4}}$ LINE SELECT. The line select menu appears. Set the items as desired.

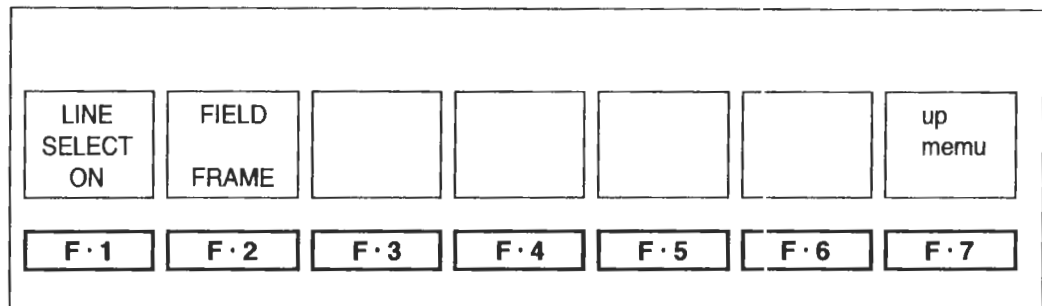

Figure 6.14 Line Select Menu

6.8.1 Line Select

[$\text{\textcircled{WFM}}$ \rightarrow $\text{\textcircled{F.4}}$ LINE SELECT \rightarrow $\text{\textcircled{F.1}}$ LINE SELECT :ON / OFF]

To enable the line select display on the video signal waveform display, press the $\text{\textcircled{F.1}}$ LINE SELECT key from the line select menu and select ON. Then, turn the function dial ($\text{\textcircled{F.D}}$) $\text{\textcircled{19}}$ to display an arbitrary line.

Select OFF to disable the line select display.

If line select is turned ON when OVERLAY is selected in section 6.3, "Display Mode Settings" and 2H is selected in section 6.7.2, "H Sweep Selection," 2-line line select is enabled. In this case, the selected line is shown on the left, and the next line is shown on the right.

6.8.2 Field Selection

[$\text{\textcircled{WFM}}$ \rightarrow $\text{\textcircled{F.4}}$ LINE SELECT \rightarrow $\text{\textcircled{F.2}}$ FIELD :FIELD1 / FIELD2 / FRAME]

When the line select display is enabled on the video signal waveform display, you can set the variable range of the function dial ($\text{\textcircled{F.D}}$) $\text{\textcircled{19}}$ to field or frame.

You cannot select the field if the video signal format is progressive.

FIELD1: Limits the range of lines that can be selected using the function dial ($\text{\textcircled{F.D}}$) $\text{\textcircled{19}}$ to field 1.

FIELD2: Limits the range of lines that can be selected using the function dial ($\text{\textcircled{F.D}}$) $\text{\textcircled{19}}$ to field 2.

FRAME: Sets the range of lines that can be selected using the function dial ($\text{\textcircled{F.D}}$) $\text{\textcircled{19}}$ to the entire frame.

6.9 Cursor Measurement

Cursor measurement is used to measure voltage, time, and other parameters. The REF and Δ cursors are used to measure the voltage and time between two points on a waveform.

To perform cursor measurements, press the WFM key $\text{\textcircled{13}}$ to display the waveform display menu. Then, select $\text{\textcircled{F.5}}$ CURSOR.

The cursor measurement menu appears. Set the items as desired.

If the pseudo-composite display is selected as described in section 6.10.1, "Color Matrix Conversion," cursor measurements on the time axis is not possible.

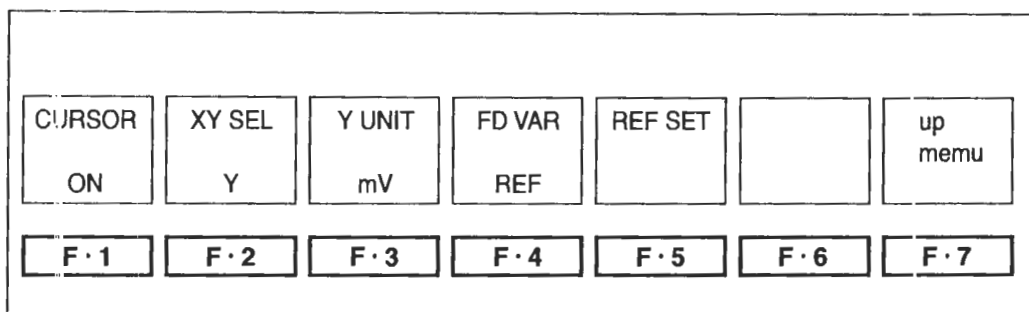

Figure 6.15 Cursor Measurement Menu

Function Key	Description
F.1 CURSOR	Turns ON/OFF the cursor display
F.2 XY SEL	Switches between the X-axis and Y-axis of the cursor.
F.3 X(Y) UNIT	Selects the cursor unit of the X-axis and Y-axis
F.4 FD VAR	Selects REF, DELTA, and TRACK using the function dial
F.5 REF SET	Sets the reference value for the relative measurement
F.D	Moves the cursor

Table 6.4 Cursor measurement menu description

6.9.1 Cursor Display

[$\text{\textcircled{WFM}}$ \rightarrow $\text{\textcircled{F.5}}$ CURSOR \rightarrow $\text{\textcircled{F.1}}$ CURSOR:ON / OFF]

To display the cursor, press $\text{\textcircled{F.1}}$ CURSOR from the cursor measurement menu and select ON.

Select OFF to clear the cursor.

6.9.2 X-Axis/Y-Axis Cursor Selection

[$\text{\textcircled{WFM}}$ \rightarrow $\text{\textcircled{F.5}}$ CURSOR \rightarrow $\text{\textcircled{F.2}}$ XY SEL :X / Y]

Select the axis to perform the cursor measurement from X-axis (time) and Y-axis (amplitude).

If the pseudo-composite display is selected as described in section 6.10.1, "Color Matrix Conversion," you cannot select the X-axis (time). Measurement is made only on the Y-axis (amplitude).

X: Measures the time using the cursor.

Y: Measures the amplitude using the cursor.

6.9.3 Cursor Measurement Unit Selection

(1) Selecting the X-Axis Cursor Unit

[**WFM**] → [**F.5**] CURSOR → [**F.3**] X UNIT :sec / Hz]

You can set the X-axis cursor unit using the [**F.3**] X UNIT key when X is selected as described in section 6.9.2, "X-Axis/Y-Axis Cursor Selection."

sec: Displays using units of seconds.

Hz: Displays using units of frequency where the interval between the cursors is taken to be one period.

If the pseudo-composite display is selected as described in section 6.10.1, "Color Matrix Conversion," cursor measurements on the X-axis is not possible.

(2) Selecting the Y-Axis Cursor Unit

[**WFM**] → [**F.5**] CURSOR → [**F.3**] Y UNIT :mV / % / R%]

You can set the Y-axis cursor unit using the [**F.3**] Y UNIT key when Y is selected as described in section 6.9.2, "X-Axis/Y-Axis Cursor Selection."

mV: Displays using units of millivolts.

%: Displays using a ratio where 700 mV is taken to be 100 % during component display.

Displays using a ratio where 714 mV is taken to be 100 % during pseudo-composite display (NTSC).

R%: Displays the relative value with respect to the reference amplitude using a ratio.

The reference amplitude is specified using the procedure given in section 6.9.5, "Reference Amplitude Setting."

6.9.4 Cursor Movement

[**WFM**] → [**F.5**] CURSOR → [**F.4**] FD VAR:REF / DELTA / TRACK]

To move the desired cursor, select [**F.4**] FD VAR from the cursor measurement menu.

REF: Moves the reference cursor using the function dial [**F.D**] ①9.

DELTA: Moves the Δ cursor using the function dial [**F.D**] ①9.

TRACK: Moves the reference cursor and Δ cursor simultaneously using the function dial [**F.D**] ①9.

6.9.5 Reference Amplitude Setting

[WFM] → [F.5] CURSOR → [F.5] REF SET]

In cursor measurement, you can make an arbitrary amplitude a reference and display the relative value using a ratio.

Relative measurements can be carried out according to the procedure below.

- ① Select R% as described in section 6.9.3 (2), "Selecting the Y-Axis Cursor Unit."
- ② Set the cursors to the reference amplitude as described in section 6.9.4, "Cursor Movement."
- ③ Press [F.5] REF SET to confirm the reference amplitude.
- ④ Measure the amplitude as described in section 6.9.4, "Cursor Movement."

6.10 Color System Setting

The SDI signals that can be monitored on the LV 5750 are limited to component signals consisting of intensity and chrominance difference signals.

Intensity and chrominance difference signals are usually represented by Y, C_B, C_R. The LV 5750 also provides a functionality that computes and displays Y, C_B, C_R signals as G, B, R signals. Furthermore, component signals can be artificially converted into NTSC or PAL signals to be displayed.

In addition, G, B, R signals can be displayed as R, G, B signals (in the order red, green and blue). The waveforms corresponding to CH1, CH2, and CH3 keys ⑪ vary according to these settings.

To set the color system, press the WFM key ⑬ to display the waveform display menu. Then, select [F.6] COLOR SYSTEM.

The color system setup menu appears. Set the items as desired.

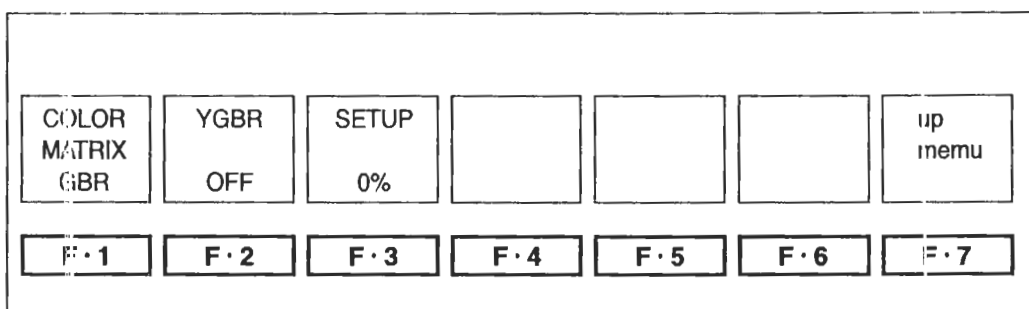

Figure 6.16 Color System Setup Menu

6.10.1 Color Matrix Conversion

[**WFM**] → [**F.6**] COLOR SYSTEM → [**F.1**] COLOR MATRIX: YCbCr / GBR / RGB / COMPOSIT]

To select the color matrix of the video signal waveform display, press [**F.1**] COLOR MATRIX from the color system setup menu.

YCbCr: Waveforms are displayed using intensity and chrominance difference signals.

CH1, CH2, and CH3 keys $\text{\textcircled{12}}$ are assigned as follows:

CH1:Y CH2:C_B CH3:C_R

GBR: Waveforms are displayed by converting the Y, C_B, C_R signal into G, B, R.

CH1, CH2, and CH3 keys $\text{\textcircled{12}}$ are assigned as follows:

CH1:G CH2:B CH3:R

RGB: Waveforms are displayed by converting the Y, C_B, C_R signal into R, G, B.

CH1, CH2, and CH3 keys $\text{\textcircled{12}}$ are assigned as follows:

CH1:R CH2:G CH3:B

COMPOSIT: The component signal is artificially converted into a pseudo-composite signal such as NTSC or PAL and displayed.

CH1, CH2, and CH3 keys $\text{\textcircled{12}}$ do not function.

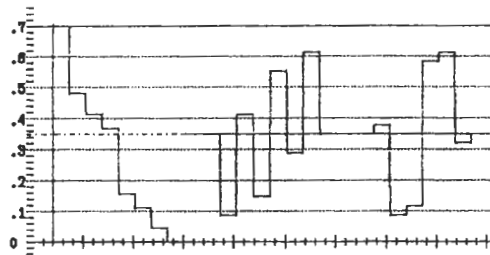

(a) Y, C_B, C_R

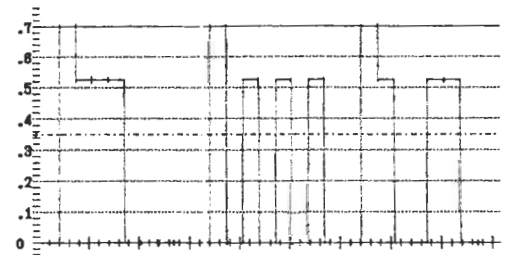

(b) G, B, R

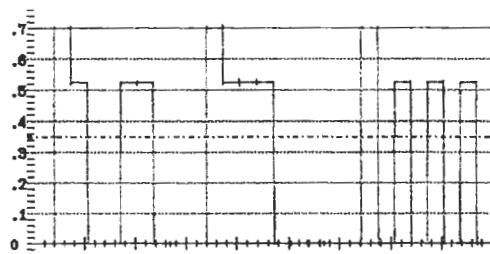

(c) R, G, B

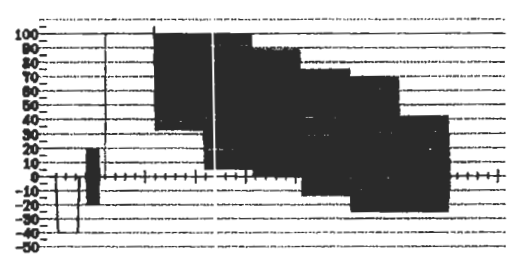

(d) COMPOSIT

Figure 6.17 Waveform Display by Color Matrix

6.10.2 Y-GBR (R, G, B) Display

[**WFM**] → [**F-6**] COLOR SYSTEM → [**F-2**] YGBR :ON / OFF]

[**WFM**] → [**F-6**] COLOR SYSTEM → [**F-2**] YRGB :ON / OFF]

To display the intensity signal (Y) and the G, B, R or R, G, B signal that has been computed through matrix conversion simultaneously, press [**F-2**] YGBR (YRGB) from the color matrix setup menu to select ON. In this case, the color matrix conversion as described in section 6.10.1, "Color Matrix Conversion," must be set to G, B, R or R, G, B. Y-GBR display is activated if G, B, R is selected; Y-RGB display is activated if R, G, B is selected. This selection is not possible if Y, C_B, C_R or pseudo-composite display is selected.

The Y-GBR display and Y-RGB display are shown only on a single screen of the video signal waveform display; it cannot be shown on the multi screen display. When Y-GBR display or Y-RGB display is selected, the CH1, CH2, and CH3 keys  are disabled.

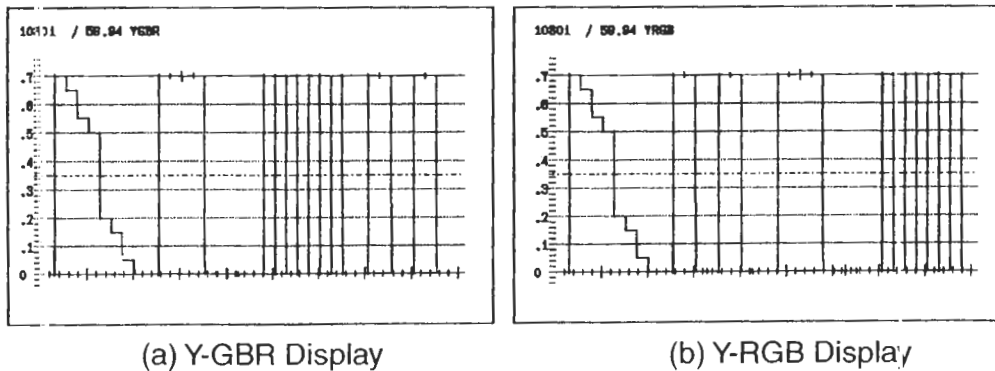

Figure 6.18 Y-GBR (RGB) Display

6.10.3 Setup Selection

[**WFM**] → [**F-6**] COLOR SYSTEM → [**F-3**] SETUP :0% / 7.5%]

If you select NTSC pseudo-composite display as described in section 6.10.1, "Color Matrix Conversion," you can select the setup level of the waveform display. From the color system setup menu, press [**F-3**] SETUP. If you select 0 %, setup is not added. If you select 7.5 %, a pseudo-composite waveform display with 7.5 % setup added is shown.

You can select setup only when using the NTSC pseudo-composite display. The menu does not appear during component display or PAL display.

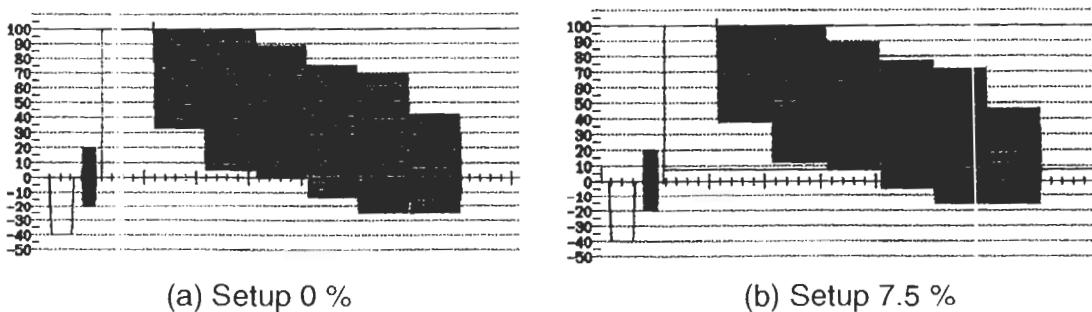

Figure 6.19 Setup Display

6.10.4 Pseudo-Composite Display

[**WFM**] → [**F.6**] COLOR SYSTEM → [**F.1**] COLOR MATRIX: YCbCr / GBR / RGB / COMPOSIT]

Only component SDI signals can be input to the LV 5750. However, by selecting COMPOSIT as described in section 6.10.1, "Color Matrix Conversion," you can display component signals as pseudo-composite signals.

If AUTO is selected as described in section 5.4.5, "Format Selection of the Pseudo-Composite Display," video signal format having a field frequency is 50 Hz or a frame frequency is 25 Hz or 50 Hz is converted into PAL. Video signal formats of other field/frame frequencies are converted into NTSC.

In the pseudo-composite display, the color burst frequency does not match the NTSC or PAL frequency; it is 1/4th the frequency of the input signal clock. In addition, when HD-SDI signals are displayed as pseudo-composite signals, the width and position of the sync signal and color burst signal are slightly different from those of the actual NTSC or PAL signals.

The line selector and V sweep are displayed using the number of lines of the original component signal.

In addition, the following limitations exist in the pseudo-composite display.

- ① The time axis cannot be expanded using sweep 1H and 2H.
- ② The time axis cannot be measured in cursor measurement.
- ③ For composite display of HD-SDI, the line select is set to that of HDTV.
- ④ Waveform display of the EAV-SAV (blanking period) is not possible.
- ⑤ The MODE key, and CH1, CH2, and CH3 keys do not function.
- ⑥ The scale is set to % (IRE) scale during NTSC display and V (voltage) scale during PAL display.

6.11 Scale Settings

The LV 5750 provides various scale settings on the video signal waveform display.

To set the scale, press the WFM key **13** to display the waveform display menu.

Then, press [**F.7**] next menu followed by [**F.1**] SCALE.

The scale setup menu appears. Set the items as desired.

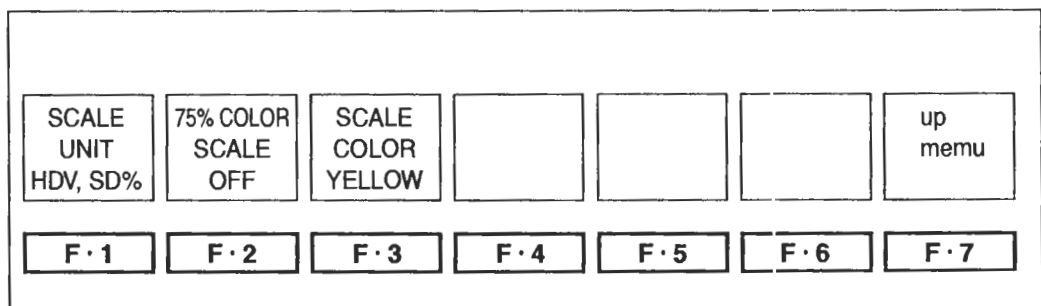

Figure 6.20 Scale Setup Menu

6.11.1 Scale Unit Selection

[**WFM**] → [**F-7**] next menu → [**F-1**] SCALE → [**F-1**] SCALE UNIT :HDV,SD% / HDV,SDV / HD%,SD%]

On the video signal waveform display, you can set the scale unit to match HDTV and SDTV separately.

From the scale setup menu, press [**F-1**] SCALE UNIT and select the scale unit of HDTV and SDTV.

HDV,SD%: V (voltage) unit for HDTV format and % unit for SDTV.

HDV,SDV: V (voltage) unit for HDTV and SDTV formats.

HD%,SD%: % unit for HDTV and SDTV formats.

The scale unit during pseudo-composite display is fixed to % (IRE) for NTSC display and V (voltage) for PAL display.

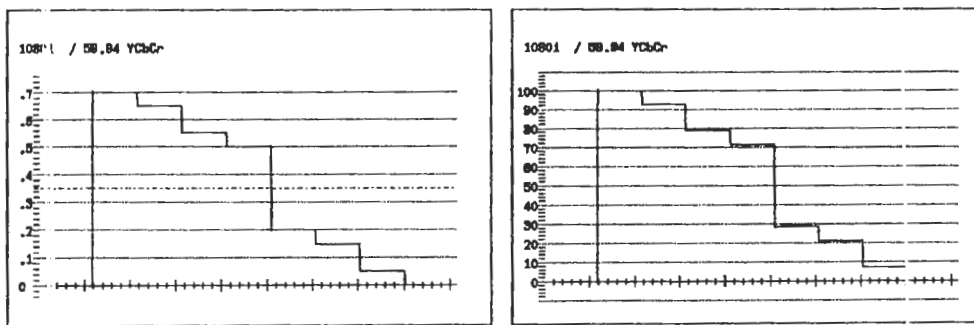

(a) Voltage scale

(b) Percentage scale

Figure 6.21 Scale unit selection

6.11.2 Display Selection of the 75 % Color Bar Scale

[**WFM**] → [**F-7**] next menu → [**F-1**] SCALE → [**F-2**] 75% COLOR SCALE ON / OFF]

You can select a scale to match the peak level of the chrominance difference signal when the 75 % color bar is displayed as a waveform.

From the scale setup menu, press [**F-2**] 75% COLOR SCALE. Select ON to show the scale, OFF to hide the scale.

The scale for 75 % color bar cannot be displayed during pseudo-composite display or G, 3, R or R, G, B display.

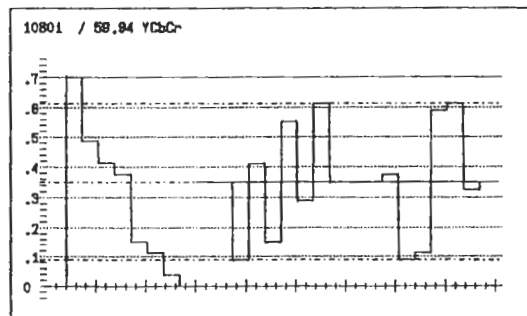

Figure 6.22 75 % Color Bar Scale

6.11.3 Scale Color Selection

[**WFM**] → [**F.7**] next menu → [**F.1**] SCALE → [**F.3**] SCALE COLOR: WHITE / YELLOW / CYAN / GREEN / MAGENTA / RED / BLUE]

You can select the scale color on the video signal waveform display. You can select the scale color from the seven colors below.

From the scale setup menu, press [**F.3**] SCALE COLOR to select the color.

- WHITE: Sets the scale color to white.
- YELLOW: Sets the scale color to yellow.
- CYAN: Sets the scale color to cyan.
- GREEN: Sets the scale color to green.
- MAGENTA: Sets the scale color to magenta.
- RED: Sets the scale color to red.
- BLUE: Sets the scale color to blue.

6.12 Blanking Display Settings

[**WFM**] → [**F.7**] next menu → [**F.2**] EAV-SAV :REMOVE / PASS]

You can select whether to display waveforms or mask to the black level during the blanking period on the video signal waveform display.

Press the WFM key **13** to display the waveform display menu. Then, press [**F.7**] next menu followed by [**F.2**] EAV-SAV to select REMOVE or PASS.

If the pseudo-composite display is selected as described in section 6.10.1, "Color Matrix Conversion," the waveform of the blanking period cannot be displayed.

- REMOVE: Signals are masked to the black level during the blanking period.
- PASS: All waveforms are displayed during the blanking period.

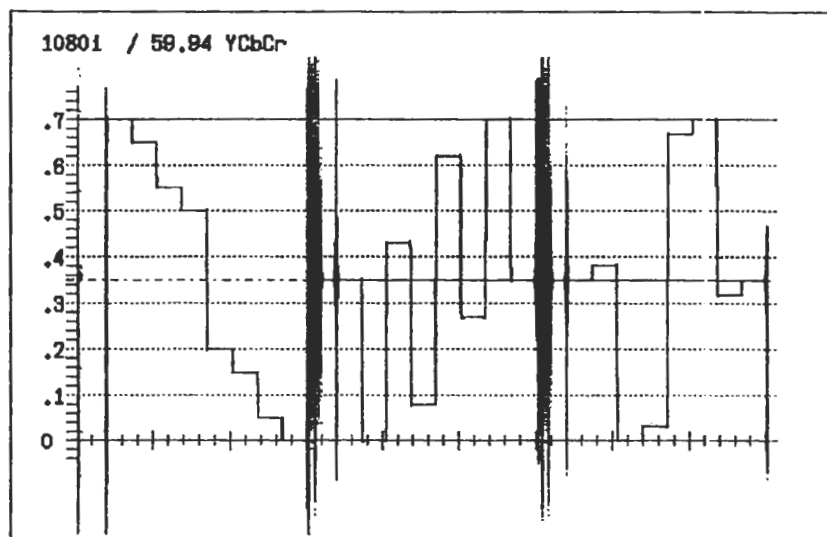

Figure 6.23 Waveform Display during the Blanking Period

6.13 Mode Key Switching

[**WFM** → **F-7** next menu → **F-4** TIMING MODE :NORMAL / PASS]

You can select whether to allow the timing display to be selected when the MODE key **0** is pressed.

Press the WFM key **13** to display the waveform display menu. Then, press **F-7** next menu followed by **F-4** TIMING.

NORMAL: The timing display is also shown when the MODE key is pressed.

PASS: The timing display is not shown even when the MODE key is pressed.

Only overlay and parade displays are selected.

7. VECTORSCOPE DISPLAY

7.1 Vector Waveform Display

To show vector waveforms, press the VECTOR key ⑭.

The screen shows the vector waveforms, scale, and the vectorscope display menu.

The vector display of the component signal is achieved using X-Y display of C_B (horizontal) and C_R (vertical) signals.

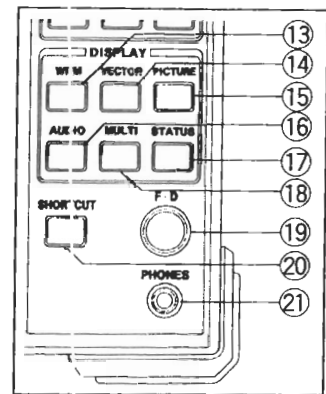

Figure 7.1 Area around the VECTOR key ⑭

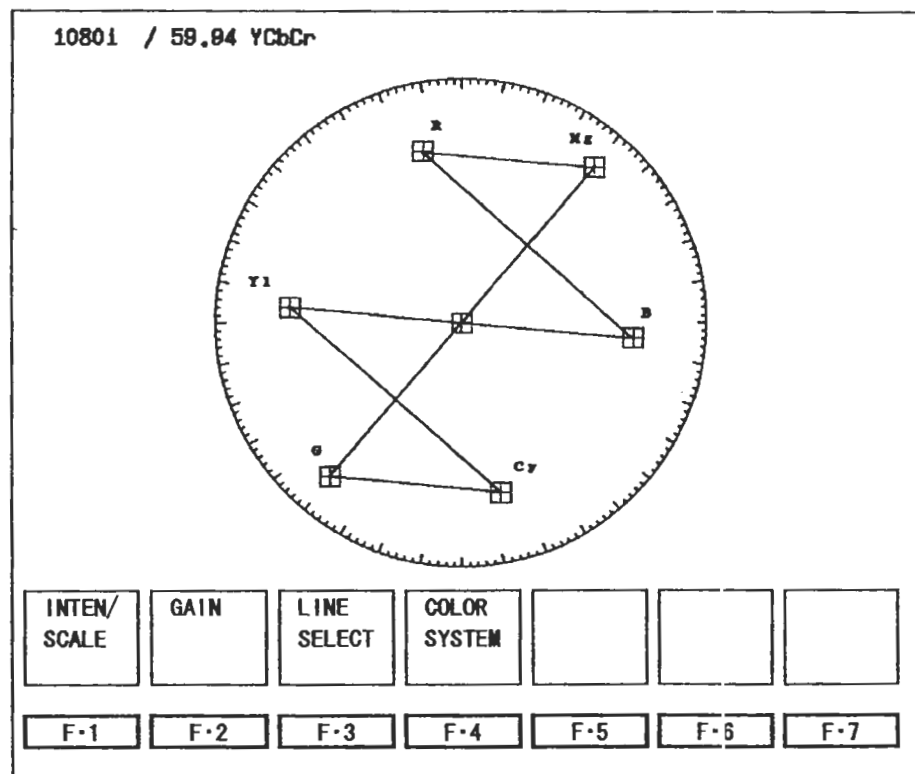

Figure 7.2 Vectorscope display and vectorscope display menu

Function Key	Description
F-1 INTEN/SCALE	Adjusts the intensity of the displayed waveform or sets the scale
F-2 GAIN	Sets the gain
F-3 LINE SELECT	Line select
F-4 COLOR SYSTEM	Sets the composite display and the color bar saturation

Table 7.1 Vectorscope display menu description

Graticule	Video Signal Format Setting	Applicable Colorimetry Standard
1	1080i/60,50 1080p/30,25,24 1080PsF/30,25,24 720/60p	SMPTE 274M, 296M
2	525i/60,625i/50	SMPTE 125M

- Frame Amplitude $\pm 3\%$ of full scale (0.7 V)
- Circle $+20\%$ (HDTV) with respect to green with maximum color amplitude,
 $+20\%$ (SDTV) with respect to red with maximum color amplitude

Table 7.2 Video signal format and applicable colorimetry standard

7.2 Brightness Adjustment

To adjust the brightness of the vectorscope display or scale, press the VECTOR key (14) to display the vectorscope display menu. Then, press [F.1] INTEN/SCALE. The brightness and scale adjustment menu appears. Make the appropriate adjustment.

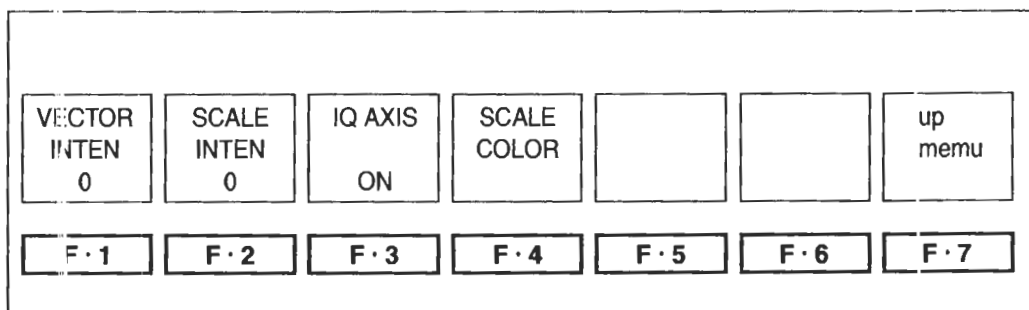

Figure 7.3 Brightness and scale setup menu

7.2.1 Brightness Adjustment of Vector Waveforms

[[VECTOR] → [F.1] INTEN/SCALE → [F.1] VECTOR INTEN → [F.D]]

To adjust the brightness of the vectorscope display, press [F.1] VECTOR INTEN from the brightness and scale setup menu. Then, turn the function dial ([F.D]) (19) to adjust the brightness.

The adjustment range is from -128 to 127.

The function dial ([F.D]) (19) also functions as a switch. Press the switch to reset the brightness of vector waveforms to the reference value (0).

7.2.2 Scale Brightness Adjustment

[[VECTOR] → [F.1] INTEN/SCALE → [F.2] SCALE INTEN → [F.D]]

To adjust the brightness of the scale on the vectorscope display, press [F.2] SCALE INTEN from the brightness and scale adjustment menu and turn the function dial ([F.D]) (19) to make the adjustment.

The adjustment range is from -8 to 7 (16 levels).

The function dial ([F.D]) (19) also functions as a switch. Press the switch to reset the brightness of the scale on the vectorscope display to the reference value (4).

7.2.3 IQ Axis Display

[VECTOR] → [F.1] INTEN/SCALE → [F.3] IQ AXIS :ON / OFF]

To display the IQ axis on the vectorscope display, press [F.3] IQ AXIS from the scale setup menu and select ON or OFF.

The IQ axis cannot be displayed for 625/50i.

- IQ axis on HDTV The following axis are displayed when the full scale value of 0.7 V is taken to be 100 %.

I axis	G=44.559 %	Q axis	G=37.056 %
	B=27.865 %		B=84.085 %
	R=69.120 %		R=62.417 %

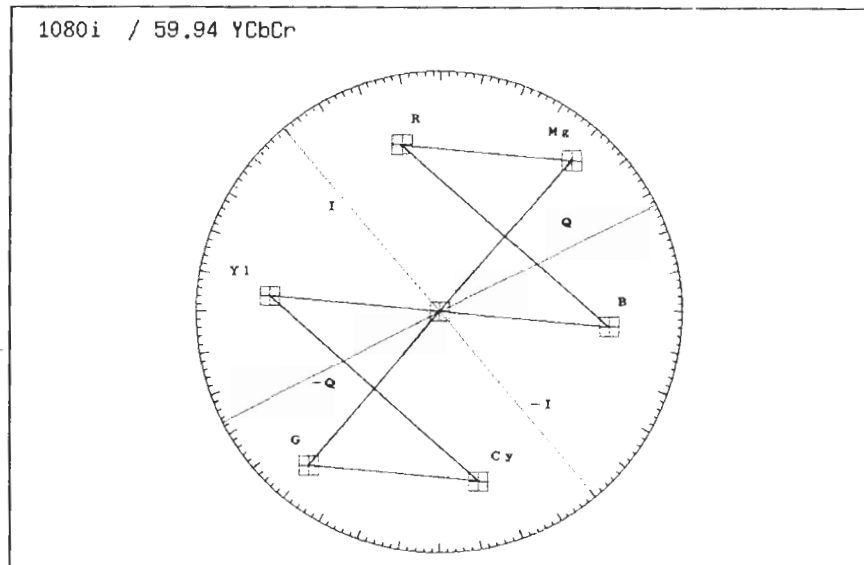

Figure 7.4 IQ axis on the vectorscope display

7.2.4 Scale Color Selection

[VECTOR] → [F.1] INTEN/SCALE → [F.4] SCALE COLOR :WHITE / YELLOW / CYAN / GREEN / MAGENTA / RED / BLUE]

You can select the scale color on the vectorscope display. You can select the scale color from the seven colors below.

From the brightness and scale setup menu, press [F.4] SCALE COLOR to select the color.

WHITE:	Sets the scale color to white.
YELLOW:	Sets the scale color to yellow.
CYAN:	Sets the scale color to cyan.
GREEN:	Sets the scale color to green.
MAGENTA:	Sets the scale color to magenta.
RED:	Sets the scale color to red.
BLUE:	Sets the scale color to blue.

7.3 Gain Adjustment

To adjust the gain of the vector waveforms, press the VECTOR key (14). Then, select [F-2] GAIN from menu that appears.

The gain adjustment menu appears. Set the items as desired.

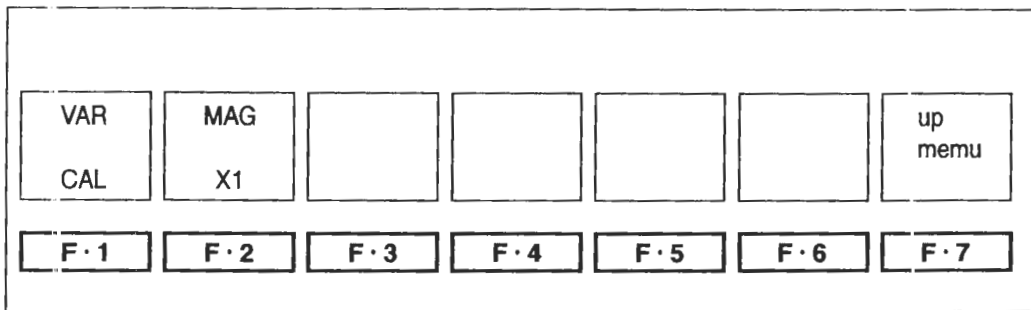

Figure 7.5 Gain adjustment menu

7.3.1 Gain Variable

[[VECTOR] → [F-2] GAIN → [F-1] GAIN VAR :CAL / VAR]

To continuously change the gain of the vector waveform (variable), press [F-1] GAIN VAR from the gain adjustment menu.

When you select VAR, you can change the gain continuously using the function dial ([F-D]) (19).

Select CAL to set the gain to the reference value. The variable range of gain is x0.20 to x2.00 with respect to the reference gain.

CAL: Sets the reference gain

VAR: Sets the variable gain

The function dial ([F-D]) (19) also functions as a switch. Press the switch while VAR is selected to reset the gain to the reference value.

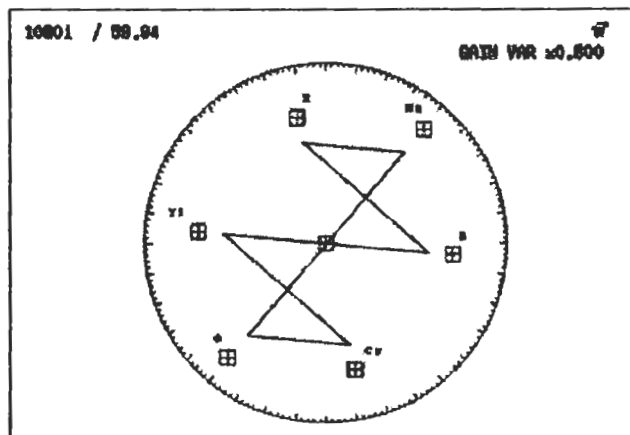

Figure 7.6 Gain Variable Display

7.3.2 Gain Selection

[VECTOR] → [F.2] GAIN → [F.2] GAIN MAG :X1 / X5 / IQ-MAG]

To change the gain of the video signal waveform to X1 or X5, press [F.2] GAIN MAG from the gain adjustment menu.

Select X5 to set the gain to X5. Select X1 to set the gain to the reference value (X1).

If you select IQ-MAG, the IQ signal is positioned on the circumference of the vectorscope graticule when the NTSC SMPTE color bar is up-converted to HDTV.

The magnification of the IQ-MAG gain is as follows:

COLOR BARS

when set to 75 % 3.1 times

7.4 Line Selector

You can monitor a particular line by using the line selector function of the vectorscope display.

From the vectorscope display menu, press [F.3] LINE SELECT.

The line select menu appears. Set the items as desired.

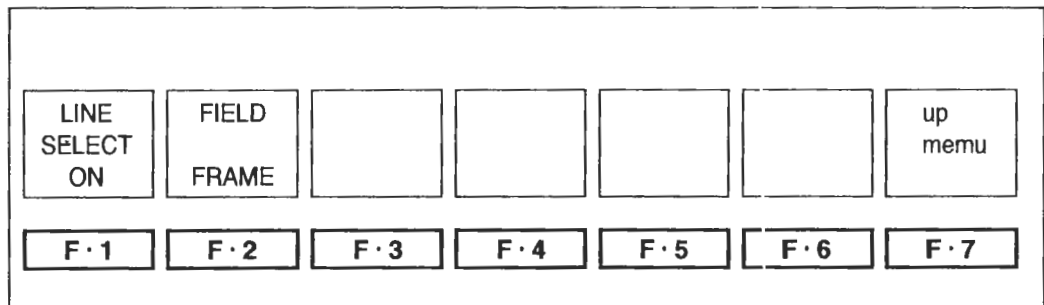

Figure 7.7 Line select menu

7.4.1 Line Select

[VECTOR] → [F.3] LINE SELECT → [F.1] LINE SELECT :ON / OFF]

To select a line to be displayed on the vectorscope display, press [F.1] LINE SELECT from the line select menu and select ON. Select OFF to clear the line selector function and display all the lines.

Select the line using the function dial ([F.D]) ①9.

7.4.2 Field Selection

[VECTOR] → [F.3] LINE SELECT → [F.2] FIELD :FIELD1 / FIELD2 / FRAME]

When the line select display is enabled on the vectorscope display, you can set the variable range of the function dial ([F.D]) ①9 to field or frame.

You cannot select the field if the video signal format is progressive.

FIELD1: Limits the range of lines that can be selected using the function dial ([F.D]) ①9 to field 1.

FIELD2: Limits the range of lines that can be selected using the function dial ([F.D]) ①9 to field 2.

FRAME: Sets the range of lines that can be selected using the function dial ([F.D]) ①9 to the entire frame.

7.5 Color System Settings

The vectorscope display of component signals is X-Y display of chrominance difference signals. However, you can also convert the signal into pseudo-composite signal to be displayed on the vectorscope.

You can also set the setup and the color bar saturation.

To set these color system parameters, press **[F.4]** COLOR SYSTEM from the vectorscope display menu.

The color system setup menu appears. Set the items as desired.

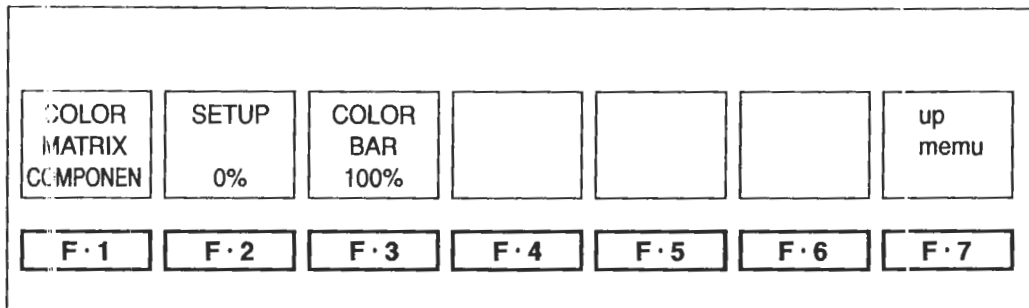

Figure 7.8 Color system setup menu

7.5.1 Composite and Component Display

[VECTOR] → **[F.4]** COLOR SYSTEM → **[F.1]** COLOR MATRIX :COMPONEN / COMPOSIT]

To display component signals artificially as composite signals on the vectorscope display, press **[F.1]** COLOR MATRIX from the color system setup menu and select COMPOSIT.

If you select COMPONEN, vectorscope display using chrominance difference signals is shown.

COMPONEN: Displays the chrominance difference signals of the component signal on the X-Y vectorscope display.

COMPOSIT: The component signal is artificially converted into a composite signal and shown on the vectorscope display.

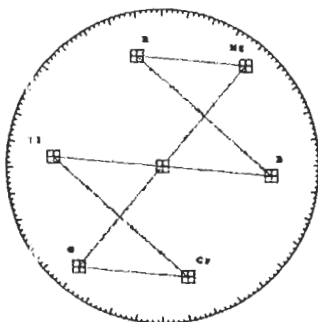

(a) Chrominance difference signal vectorscope display

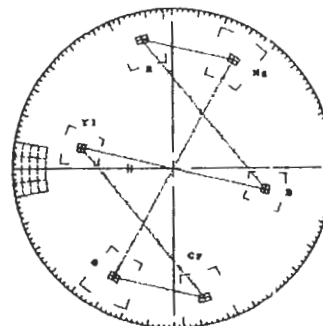

(b) Pseudo-composite vectorscope display

Figure 7.9 Chrominance difference signal vectorscope display and pseudo-composite vectorscope display

7.5.2 Setup Selection

[**VECTOR**] → [**F.4**] COLOR SYSTEM → [**F.2**] SETUP :0 % / 7.5 %]

If composite display is selected as described in section 7.5.1, "Composite and Component Display," you can select the setup level of the vectorscope display.

From the color system setup menu, press [**F.2**] SETUP. If you select 0 %, setup is not added. If you select 7.5 %, a pseudo-composite waveform display with 7.5 % setup added is shown.

You can select setup only when using the pseudo-composite display. The menu does not appear during component display.

7.5.3 Color Bar Saturation Selection

[**VECTOR**] → [**F.4**] COLOR SYSTEM → [**F.3**] COLOR BAR :100 % / 75 %]

To select the 100 % color bar or 75 % color bar, press [**F.3**] COLOR BAR from the color system setup menu and select 100 % or 75 %.

8. PICTURE DISPLAY

Press the PICTURE key ⑮ to display the picture.

SDTV is displayed with an aspect ratio of 4 to 3; HDTV is displayed with an aspect ratio of 16 to 9.

The picture display on the LV 5750 shows pictures using simplified resolution conversion. Therefore, it cannot display all the details included in the SDI signal.

The LCD on the LV 5750 shows pictures asynchronously with the input SDI signal by performing frame rate conversion on the internal circuit. Therefore, the screen may flicker due to phenomena known as frame repeat and frame skip.

There are two modes available, FIT mode which displays the picture on full screen and x1 mode which displays the signal pixels without magnification.

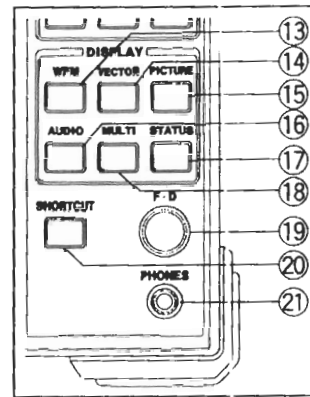

Figure 8.1 Area around the PICTURE key ⑮

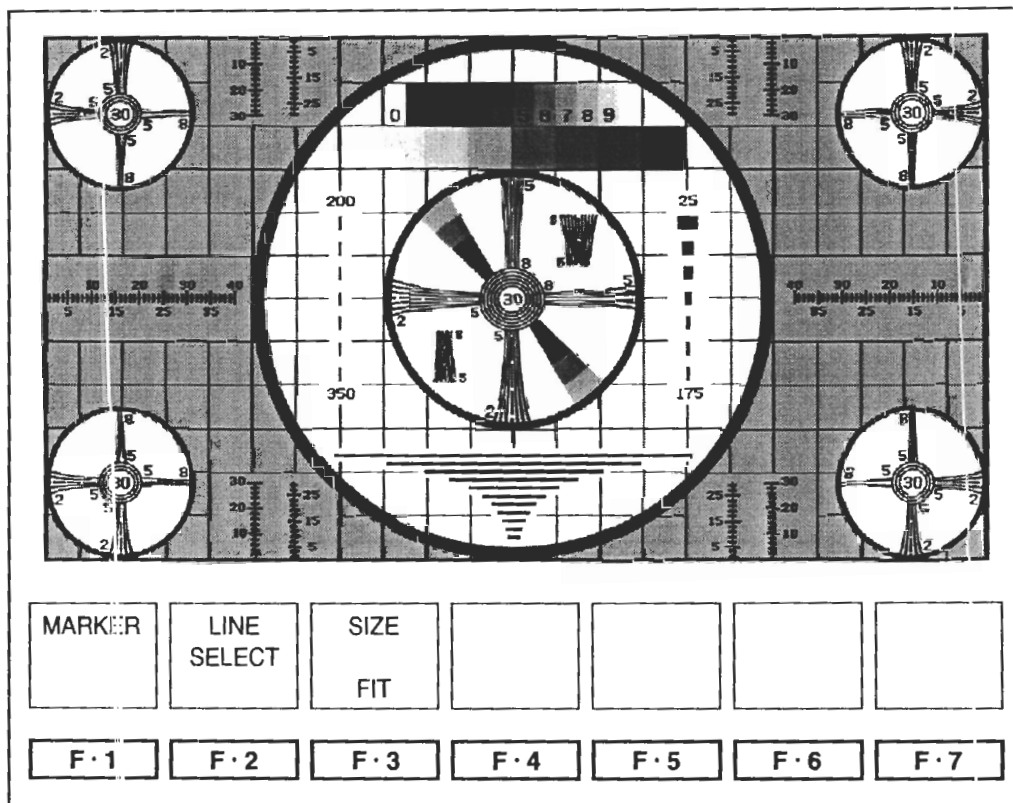

Figure 8.2 Picture Display Menu

8.1 Marker Display

To show the safety marker on the picture display, press **[F.1]** MARKER to show the marker display menu.

As shown in the figure above, four marker sizes are available according to the input signal and aspect marker.

Markers cannot be displayed when showing the multi screen display.

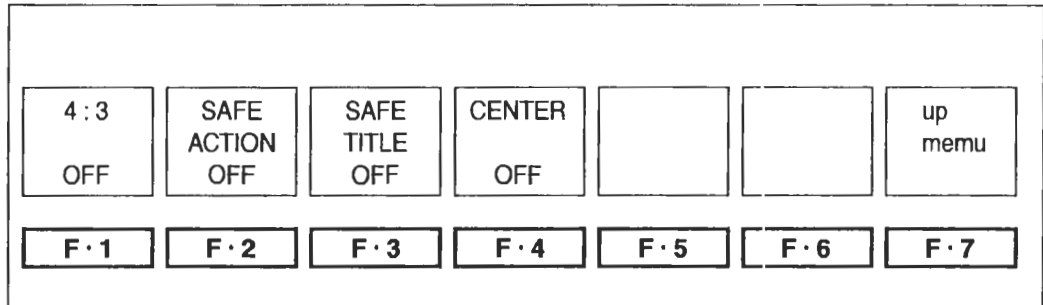

Figure 8.3 Marker Display Menu

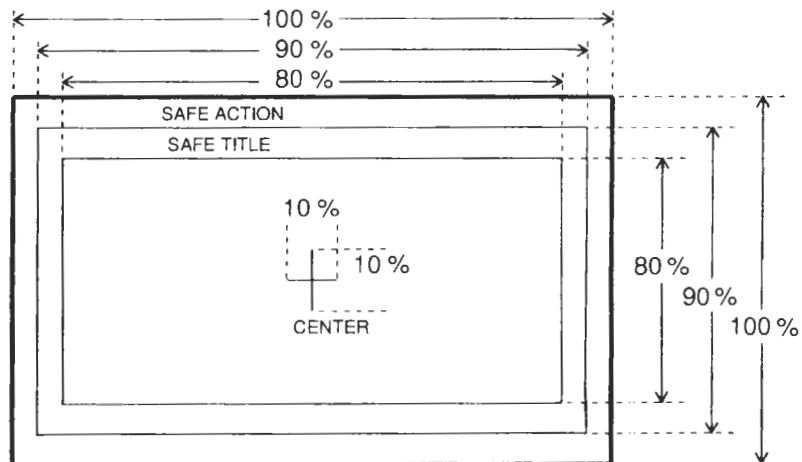

Figure 8.4 HD-SDI Marker Display (4:3 OFF)

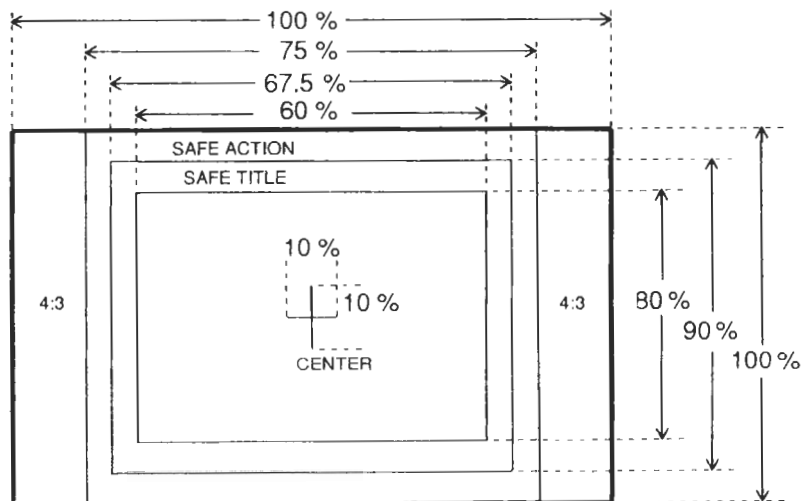

Figure 8.5 HD-SDI Marker Display (4:3 ON)

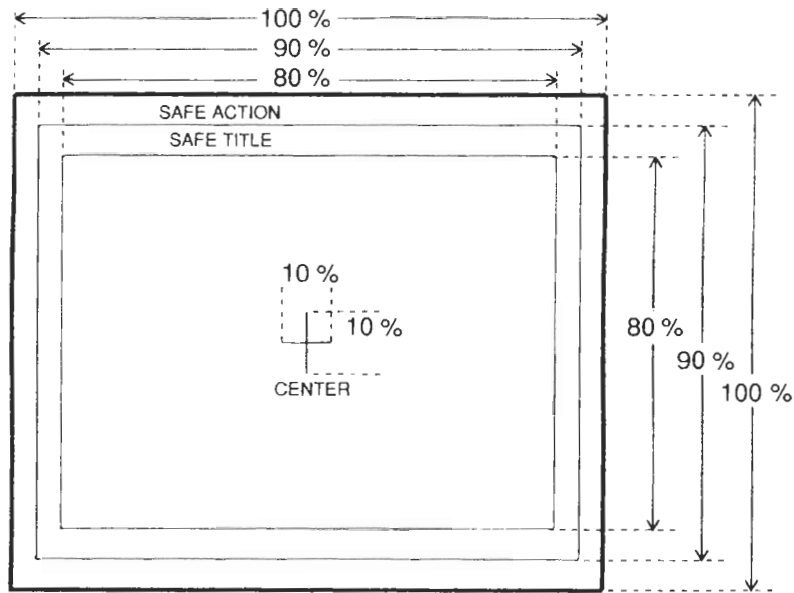

Figure 8.6 SD-SDI Marker Display (16:9 OFF)

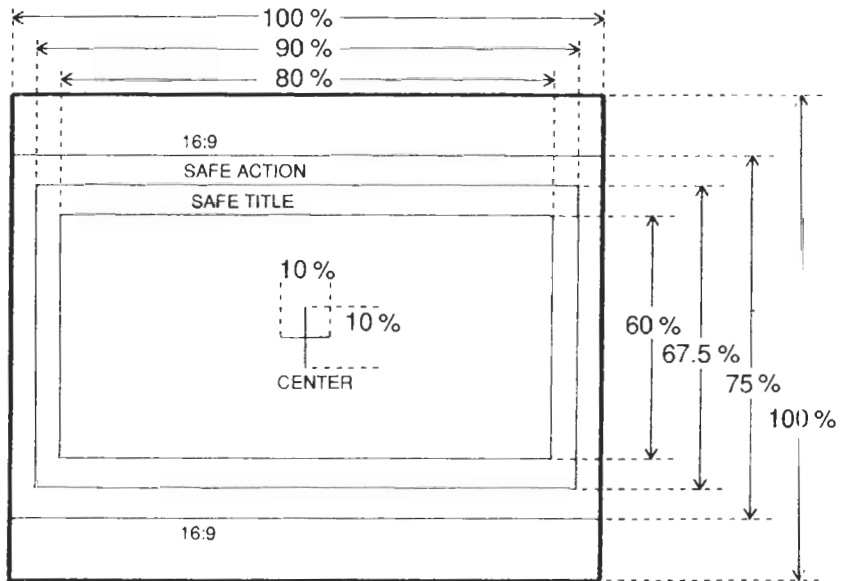

Figure 8.7 SD-SDI Marker Display (16:9 ON)

8.1.1 Aspect Marker (4:3)

[PICTURE] → [F.1] MARKER → [F.1] 4:3: ON / OFF]

When displaying HD-SDI signals with the picture aspect ratio of 16:9, the marker can be displayed at the position corresponding to 4:3. Depending on whether the 4:3 aspect marker display is ON, the sizes of the safe action marker and safe title marker are different.

The aspect marker can be turned ON/OFF by pressing [F.1] 4:3 from the marker display menu.

8.1.2 Aspect Marker (16:9)

[PICTURE] → [F.1] MARKER → [F.1] 16:9: ON / OFF]

When displaying SD-SDI signals with the picture aspect ratio of 4:3, the marker can be displayed at the position corresponding to 16:9. Depending on whether the 16:9 aspect marker display is ON, the sizes of the safe action marker and safe title marker are different.

The aspect marker can be turned ON/OFF by pressing [F.1] 16:9 from the marker display menu.

8.1.3 Safe Action Marker

[PICTURE] → [F.1] MARKER → [F.2] SAFE ACTION: CN / OFF]

Safe action markers can be displayed at the 90 % positions vertically and horizontally with respect to the active area on the picture display.

If the aspect marker is displayed, the safe action markers are displayed at the 90% positions vertically and horizontally with respect to the aspect marker.

The safety action marker display is selected by pressing [F.2] SAFE ACTION from the marker display menu.

8.1.4 Safe Title Marker

[PICTURE] → [F.1] MARKER → [F.3] SAFE TITLE: ON / OFF]

Safe title markers can be displayed at the 80 % vertical and horizontal positions with respect to the active area on the picture display.

If the aspect marker is displayed, the safe title markers are displayed at the 80% positions vertically and horizontally with respect to the aspect marker.

The safety title marker display is selected by pressing [F.3] SAFE TITLE from the marker display menu.

8.1.5 Center Marker

[PICTURE] → [F.1] MARKER → [F.4] CENTER: ON / OFF]

A center marker (cross hairs) can be displayed at the center of the picture display.

The center marker display is selected by pressing [F.4] CENTER from the marker display menu.

8.2 Line Select Marker Display

You can check the position of a particular line by using the line selector function of the picture waveform.

From the picture display menu, press **[F.2]** LINE SELECT.

The line select menu appears. Set the items as desired.

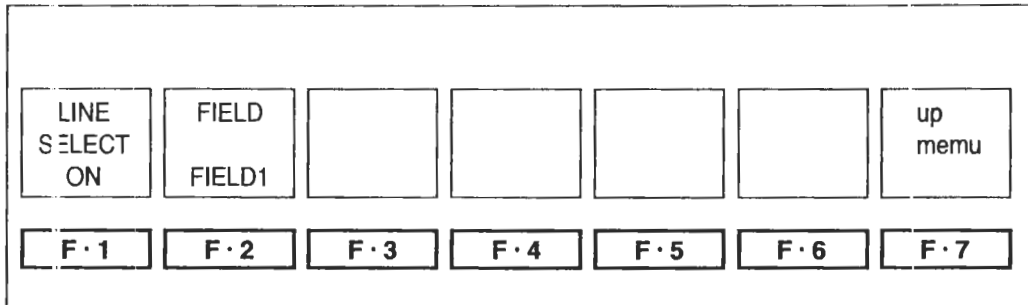

Figure 8.8 Line select menu

8.2.1 Line Select Marker Display

[**[PICTURE]** → **[F.2]** LINE SELECT → **[F.1]** LINE SELECT :ON / OFF]

The line select function allows the selected line to be displayed highlighted on the picture display.

The selectable range of line select is within the active picture area; Line select is not displayed during the blanking period.

From the line select menu, press **[F.1]** LINE SELECT to select ON. Then, turn the function dial (**[F.D]**) ⑲ to select the line.

8.2.2 Field Selection of Line Select

[**[PICTURE]** → **[F.2]** LINE SELECT → **[F.2]** FIELD :FIELD1 / FIELD2 / FRAME]

When the line select display is enabled on the picture display, you can set the variable range of the function dial (**[F.D]**) ⑲ to field or frame.

You cannot select the field if the video signal format is progressive.

FIELD1: Limits the range of lines that can be selected using the function dial (**[F.D]**) ⑲ to field 1.

FIELD2: Limits the range of lines that can be selected using the function dial (**[F.D]**) ⑲ to field 2.

FRAME: Sets the range of lines that can be selected using the function dial (**[F.D]**) ⑲ to the entire frame.

When interlace format is displayed as a picture, each field is converted into the XGA rate to be displayed. Since the interlace display is not actually used, the marker position does not change even if you change the field with the line select function.

8.3 Picture Size Change

The picture display on the LV 5750 is adjusted to the number of pixels on the LCD. If an HD-SDI signal, which has more pixels than the LCD, is applied, the image is simply sampled and reduced in size. If an SD-SDI signal, which has less pixels than the LCD, is applied, the pixels are interpolated and the image is enlarged. When an image is simply sampled, narrow lines and points of the image may be lost and not displayed. When an image is displayed by interpolation, the image may appear out of focus. You can display the picture without magnification to prevent these effects.

[PICTURE] → [F.3] SIZE : FIT / x1]

Press [F.3] SIZE from the picture display menu and select FIT to display the SDI signal adjusted to the LCD size. Select x1 to display the SDI signal using the original number of pixels (not adjusted).

FIT: Displays the picture by converting the resolution

x1: Displays the picture without converting the resolution

If x1 is selected for HD-SDI signal input, the picture runs off the LCD. If this happens, you can turn the V POS ⑨ and H POS ⑩ dials to move the position of the picture display.

For SD-SDI signals, the pixels are not square. As a result, if x1 is selected the picture will appear distorted, because the aspect ratio will not be 4:3.

9. AUDIO DISPLAY

The embedded audio signal can be separated from the SDI signal and displayed as a sound image or shown on lissajous and level meter displays.

Of the 16 channels of embedded audio, two groups where one group consists of four channels can be displayed.

Press the AUDIO key ⑩ to display audio signals. The screen shows the audio signal waveform, level meter, audio display menu, and other items.

Only sampling frequency of 48 kHz is supported for audio signal. The signal must also be synchronized to the video signal.

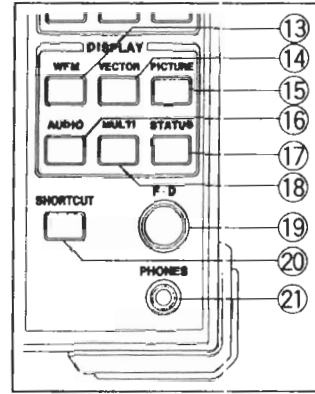

Figure 9.1 Area around the AUDIO key ⑩

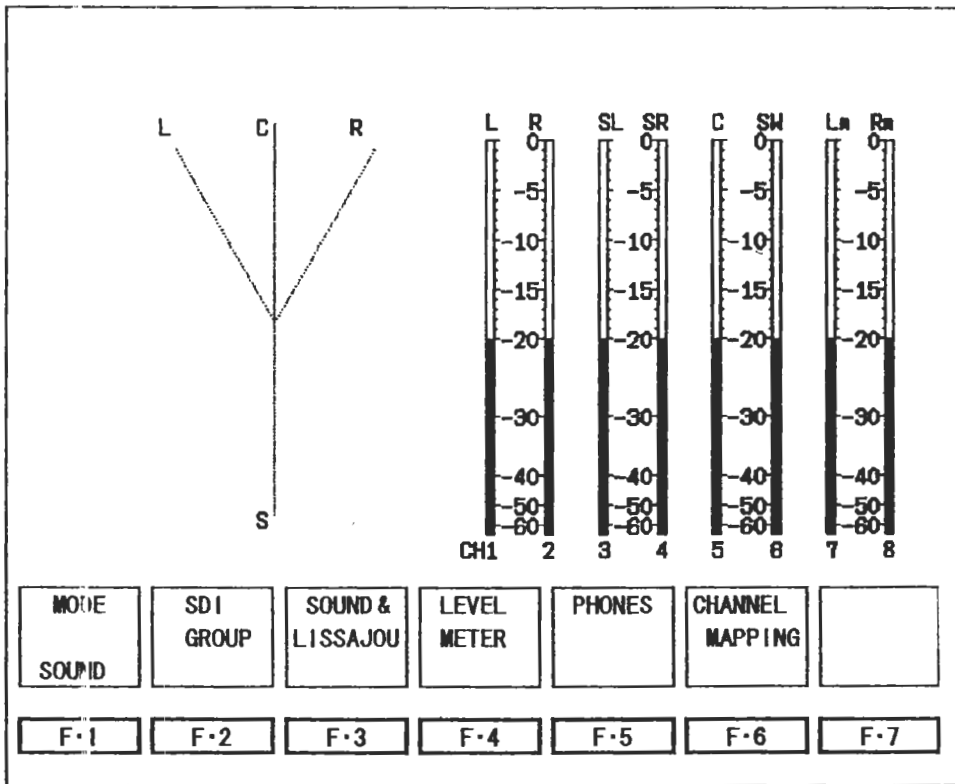

Figure 9.2 Audio Display Menu

Function Key	Description
F-1 MODE	Selects the audio waveform display format
F-2 SDI GROUP	Selects the group from which audio is decoded from the SDI signal
F-3 SOUND & LISSAJOU	Sets the sound image and lissajous display
F-4 LEVEL METER	Sets the level meter display
F-5 PHONES	Sets the headphone output
F-6 CHANNEL MAPPING	Maps channels on the sound image display

Table 9.1 Audio display menu description

9.1 Audio Waveform Display Selection

[**AUDIO**] → [**F-1**] MODE :SOUND / LISSAJOU / MLT_LISS / VALUE]

To display the audio signal, press [**F-1**] MODE from the audio display menu and select sound image, lissajous, multi-lissajous, or level value display.

These displays are shown on the left side of the screen. A level meter is displayed on the right side.

The right-most meter on the lissajous display is called a phase meter. When the meter points to +1, it indicates that the L and R channels are in-phase. Indications of -1 and 0 correspond to reverse phase and no correlation, respectively.

SOUND: Displays the sound image using waveforms.

LISSAJOU: Displays lissajous using waveforms.

MLT_LISS: Displays four-screen (eight channels simultaneously) lissajous using waveforms.

VALUE: Displays audio levels using values.

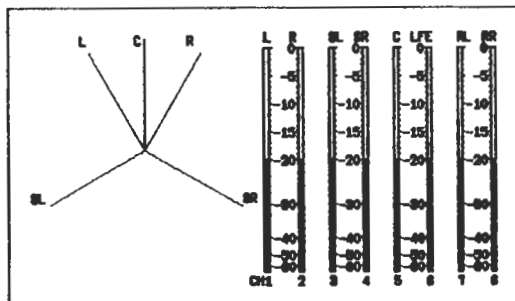

(a) Sound image display

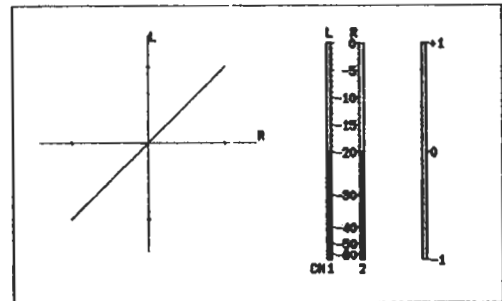

(b) Lissajous display

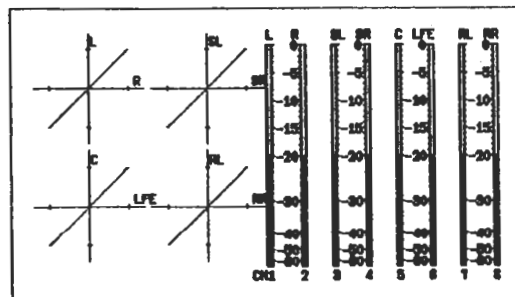

(c) Four-screen lissajous display

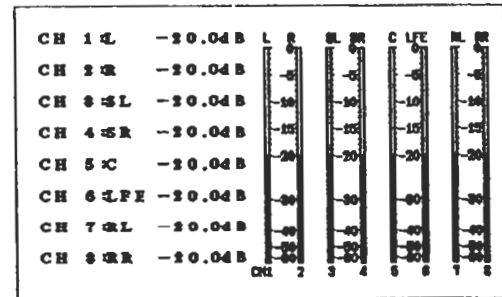

(d) Value level display

Figure 9.3 Types of audio waveform displays

9.2 Embedded Audio Group Selection

[**AUDIO**] → [**F.2**] SDI GROUP: [**F.1**] 1st GROUP/ [**F.2**] 2nd GROUP : 1 / 2 / 3 / 4]

The 15 channels of embedded audio are divided into 4 groups (4 channels to a group). Of the 4 groups, you can select 2 groups to be displayed. [**F.1**] 1st GROUP selects the first 4 channels from the 8 channels; [**F.2**] 2nd GROUP selects the next 4 channels.

9.3 Audio Waveform Display Setting

To set the audio waveform display, press the AUDIO key **(16)** to display the audio display menu. Then, select [**F.3**] SOUND & LISSAJOU.

The audio waveform display menu appears. Set the items as desired.

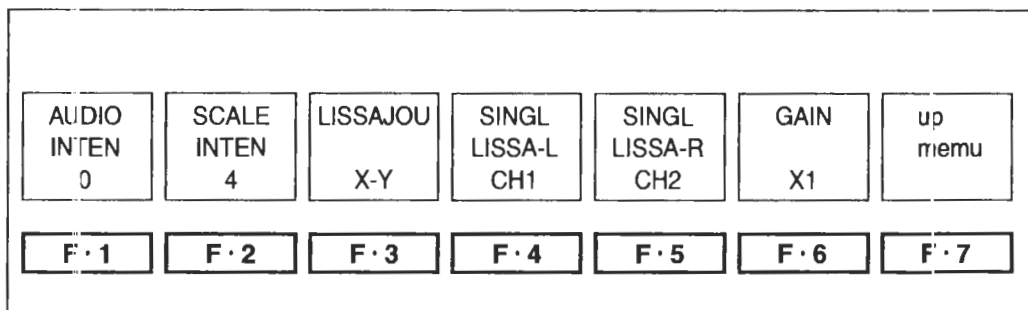

Figure 9.4 Audio waveform display menu

9.3.1 Brightness Adjustment of Audio Waveforms

[**AUDIO**] → [**F.3**] SOUND & LISSAJOU → [**F.1**] AUDIO INTEN → [**F.D**]]

To adjust the brightness of audio waveforms, press [**F.1**] AUDIO INTEN from the audio waveform display menu and turn the function dial (**F.D**) **(19)** to adjust the level in the range of -8 to 7.

The function dial (**F.D**) **(19)** also functions as a switch. Press the switch to reset the brightness of audio waveforms to the reference value (0).

9.3.2 Scale Brightness Adjustment

[**AUDIO**] → [**F.3**] SOUND & LISSAJOU → [**F.2**] SCALE INTEN → [**F.D**]]

To adjust the brightness of the scale, press [**F.2**] SCALE INTEN from the audio waveform display menu and turn the function dial (**F.D**) **(19)** to adjust the level in the range of -8 to 7.

The brightness adjustment of the scale also affects the brightness of the level meter display.

The function dial (**F.D**) **(19)** also functions as a switch. Press the switch to reset the brightness of the scale to the reference value (4).

9.3.3 Sound and Lissajou Display Format

[**AUDIO**] → [**F.3**] SOUND & LISSAJOU → [**F.3**] SURROUND : 3-1 / 3-2 / 3-2-2]

If sound image display (SOUND) is selected in section 9.1, "Audio Waveform Display Selection," you can select the surround system from 3-1 system, 3-2 system, and 3-2-2 system.

The surround system selection is also valid on the single lissajous display in which the L and R of lissajous channels are set to Lt and Rt, respectively. In this case, single lissajous display is shown by performing down-mixing computation according to the surround system. For details, see section 9.3.4, "Channel Selection of Lissajous Display."

To select the surround system, press [**F.3**] SOUND from the audio display menu and select 3-1, 3-2, or 3-2-2.

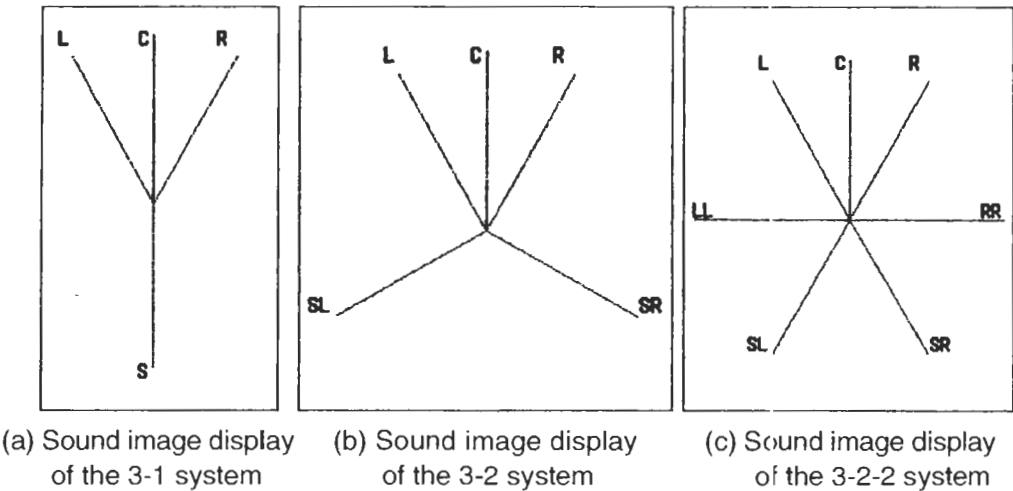

Figure 9.5 Surround system

[**AUDIO**] → [**F.3**] SOUND & LISSAJOU → [**F.3**] LISSAJOU:X-Y / MATRIX]

If lissajous display (LISSAJOU) or multi-lissajous (MULTI LISSAJOU) is selected in section 9.1, "Audio Waveform Display Selection," you can select the display format from X-Y display and matrix display.

Press [**F.3**] LISSAJOU from the audio waveform display menu and select X-Y or MATRIX.

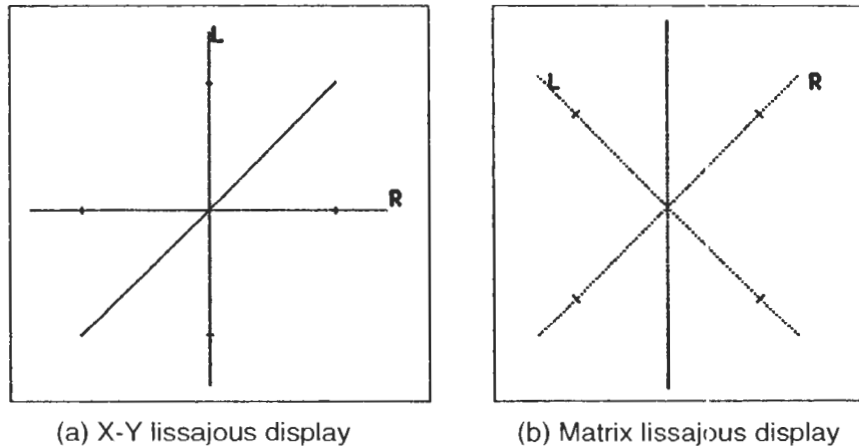

Figure 9.6 Lissajous display format

9.3.4 Lissajous Display Channel Selection

[**AUDIO**] → [**F.3**] SOUND & LISSAJOU → [**F.4**] SINGLE LISSAJ-L : 1st GROUP / 2nd GROUP / Lt]

[**AUDIO**] → [**F.3**] SOUND & LISSAJOU → [**F.5**] SINGLE LISSAJ-R : 1st GROUP / 2nd GROUP / Rt]

If lissajous display (LISSAJOU) is selected in section 9.1, "Audio Waveform Display Selection," you can select the vertical and horizontal axes for each embedded audio channels of the lissajous display. The channel selected in section 9.2, "Embedded Audio Group Selection" is displayed on the menu.

If you select Lt, Rt, the following down-mixing computation is carried out according to the name selected in section 9.6, "Channel Mapping" and assigned to Lt and Rt. Always select Lt and Rt in pairs. Otherwise, the lissajous waveforms will not be displayed correctly.

Below are the down-mixing computing equations for each surround system.

Down-mixing computing equation for the 3-1 system

$$Lt: 0.707 \times (L + 0.707C + 0.707S)$$

$$Rt: 0.707 \times (R + 0.707C + 0.707S)$$

Down-mixing computing equation for the 3-2 system

$$Lt: 0.707 \times (L + 0.707C + 0.707SL)$$

$$Rt: 0.707 \times (R + 0.707C + 0.707SR)$$

Down-mixing computing equation for the 3-2-2 system

$$Lt: 0.55 \times (L + 0.707C + 0.707RL + 0.707SL)$$

$$Rt: 0.55 \times (R + 0.707C + 0.707RR + 0.707SR)$$

9.3.5 Gain Selection

[**AUDIO**] → [**F.3**] SOUND & LISSAJOU → [**F.6**] GAIN:X1 / X2 / X10 / X0.5 / AUTO]

If you selected an item other than numerical display (VALUE) in section 9.1, "Audio Waveform Display Selection," you can set the gain of the waveform display.

Press [**F.6**] GAIN from the audio waveform display menu to select the gain factor.

X1: Reference gain value. When a reference level is applied, the display matches the scale marker.

X2: Displays at twice the reference gain.

X10: Displays at ten times the reference gain.

X0.5: Displays at 1/2 the reference gain.

AUTO: Automatically adjusts the gain.

9.4 Audio Level Meter Setting

To set the audio level meter, select [F.4] LEVEL METER from the function menu that appears by pressing the AUDIO key ⑯.

The audio level meter menu appears as shown in Figure 9.7. Select the appropriate items.

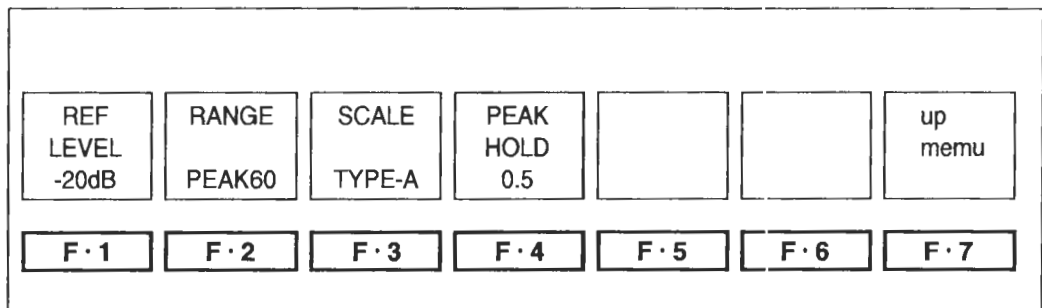

Figure 9.7 Audio Level Meter Menu

9.4.1 Reference Level Selection

[AUDIO] → [F.4] LEVEL METER → [F.1] REF LEVEL : -20 dB / -18 dB / -12 dB]

Select the reference level of the level meter from -20 dB, -18 dB, and -12 dB.

Press [F.1] REF LEVEL from the audio waveform display menu to select the reference level.

On the level meter display, levels below the reference level are indicated in white, and levels above the reference level are indicated in red.

9.4.2 Dynamic Range Selection

[AUDIO] → [F.4] LEVEL METER → [F.2] RANGE: PEAK60 / PEAK90 / AVERAGE]

You can select the dynamic range and response of the level meter.

Press [F.2] RANGE from the audio waveform display menu to select the dynamic range and response.

PEAK60: Displays a peak level meter capable of measuring down to -60 dB.

PEAK90: Displays a peak level meter capable of measuring down to -90 dB.

AVERAGE: Displays an average-response level meter from -20 dB to +3 dB with the reference level taken to be 0 dB.

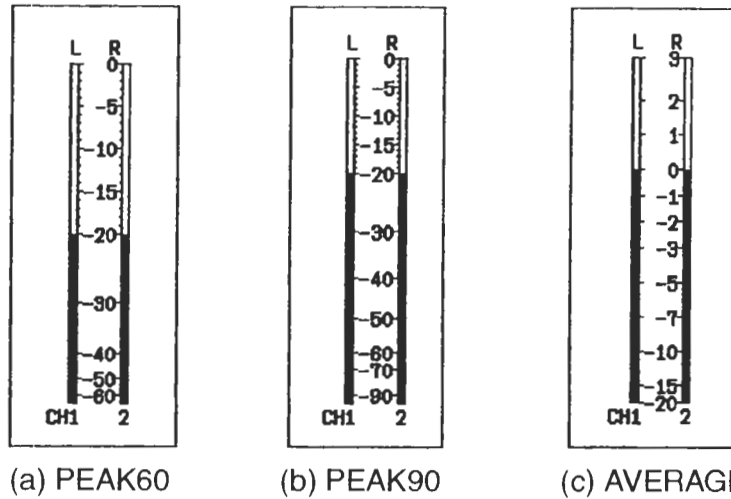

The figure shows the scale when the reference level is set to -20 dB and the scale is set to TYPE-A.

Figure 9.8 Types of dynamic range

9.4.3 Scale Selection

[AUDIO] → [F.4] LEVEL METER → [F.3] SCALE:TYPE-A / TYPE-B]

Select whether to show the reference level as 0 dB or as the reference level specified in section 9.4.1, "Reference Level Selection" on the level meter scale. Press [F.3] SCALE from the audio waveform display menu to select the scale.

TYPE-A: Level meter is displayed independent of the reference level.

TYPE-B: Level meter is displayed with the reference level as 0 dB.

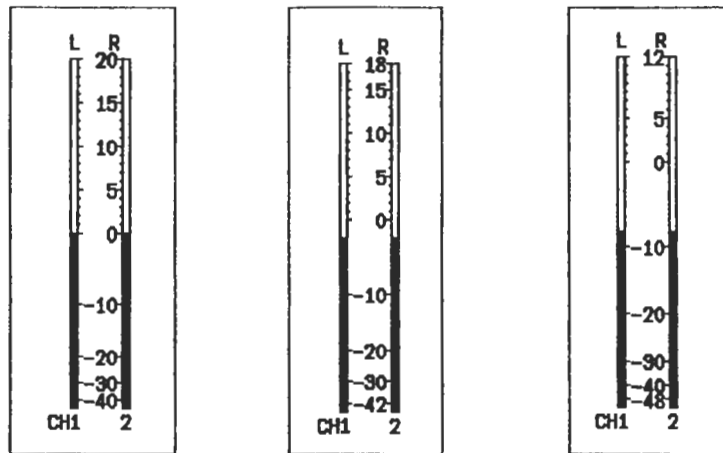

Figure 9.9 TYPE-B level meter according to the reference level

Figure 9.9 shows the scale when PEAK60 is selected.

9.4.4 Peak Hold

[**AUDIO**] → [**F.4**] LEVEL METER → [**F.4**] PEAK HOLD:0.5 to 5.0 / HOLD]

If you selected PEAK60 or PEAK90 in section 9.4.2, "Dynamic Range Selection," you can select the response time of the peak hold on the level meter. You can set the time in the range of approximately 0.5 s to 5.0 s in 0.5 steps. When you select HOLD, the peak level is held.

Adjust the response time using the function dial (**F.D**) (13).

9.5 Headphone Output Settings

To set the headphone output, press the AUDIO key (16) to display the audio display menu. Then, select [**F.5**] PHONES.

The headphone output menu shown in Figure 9.10 appears. Set each item.

The headphone output generates noise for a few seconds until the internal circuit stabilizes when the signal is inserted or removed or when the SDI signal input is switched.

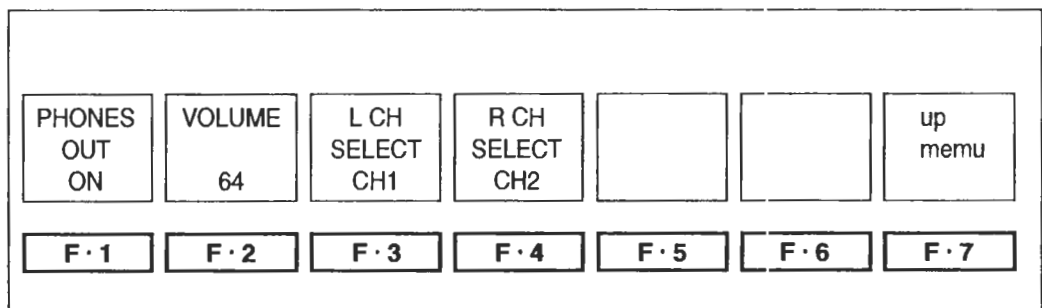

Figure 9.10 Audio Level display menu

9.5.1 Headphone Output ON/OFF

[**AUDIO**] → [**F.5**] PHONES → [**F.1**] PHONES OUT : ON / OFF]

You can turn the headphone output ON/OFF.

9.5.2 Headphone Output Volume

[**AUDIO**] → [**F.5**] PHONES → [**F.2**] VOLUME : 0 ~ 128]

You can control the headphone output volume.

You can also control the headphone output volume using the short cut key. For details, see section 5.8, "Shortcut Key Setting."

9.5.3 Headphone Output Channel Selection

[**AUDIO**] → [**F.5**] PHONES → [**F.3**] L CH SELECT : 1st GROUP / 2nd GROUP]

[**AUDIO**] → [**F.5**] PHONES → [**F.4**] R CH SELECT : 1st GROUP / 2nd GROUP]

You can set the L and R channels of the headphone output. The channel selected in section 9.2, "Embedded Audio Group Selection" is displayed on the menu.

9.6 Channel Mapping

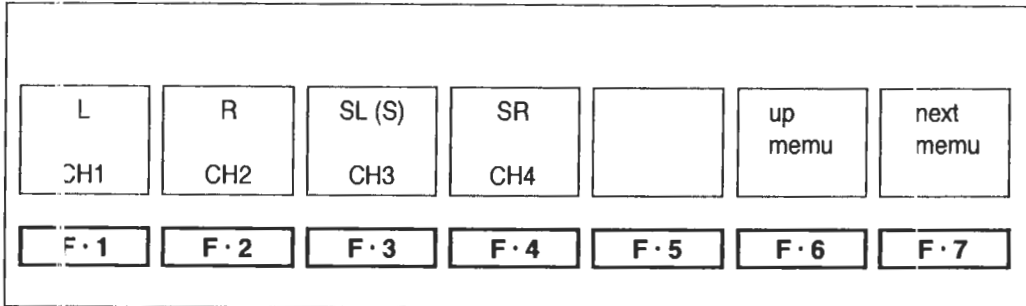

Figure 9.11 Audio display menu page 1

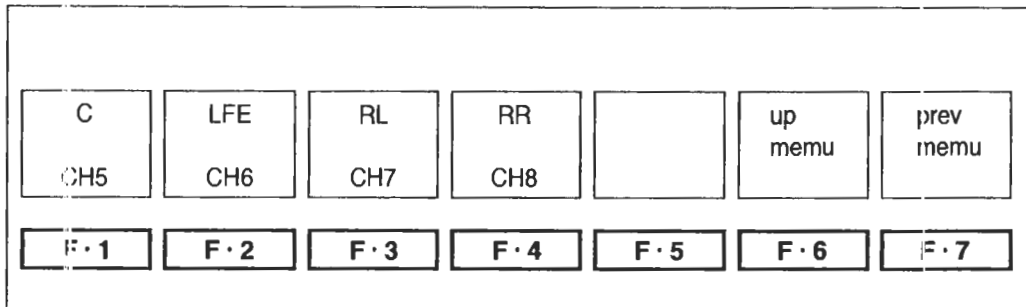

Figure 9.12 Audio display menu page 2

You can map the surround positions to the audio signal channels to produce a correct waveform display on the sound image display.

The selectable groups of channels can be switched as described in section 9.2, "Embedded Audio Group Selection."

10. MULTI SCREEN DISPLAY

Press the MULTI key ⑱ to display various information such as video signal waveform display and picture display and the multi screen menu.

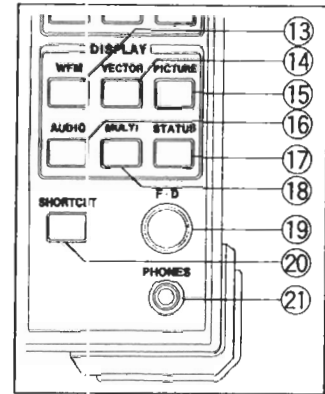

Figure 10.1 Area around the MULTI key ⑱

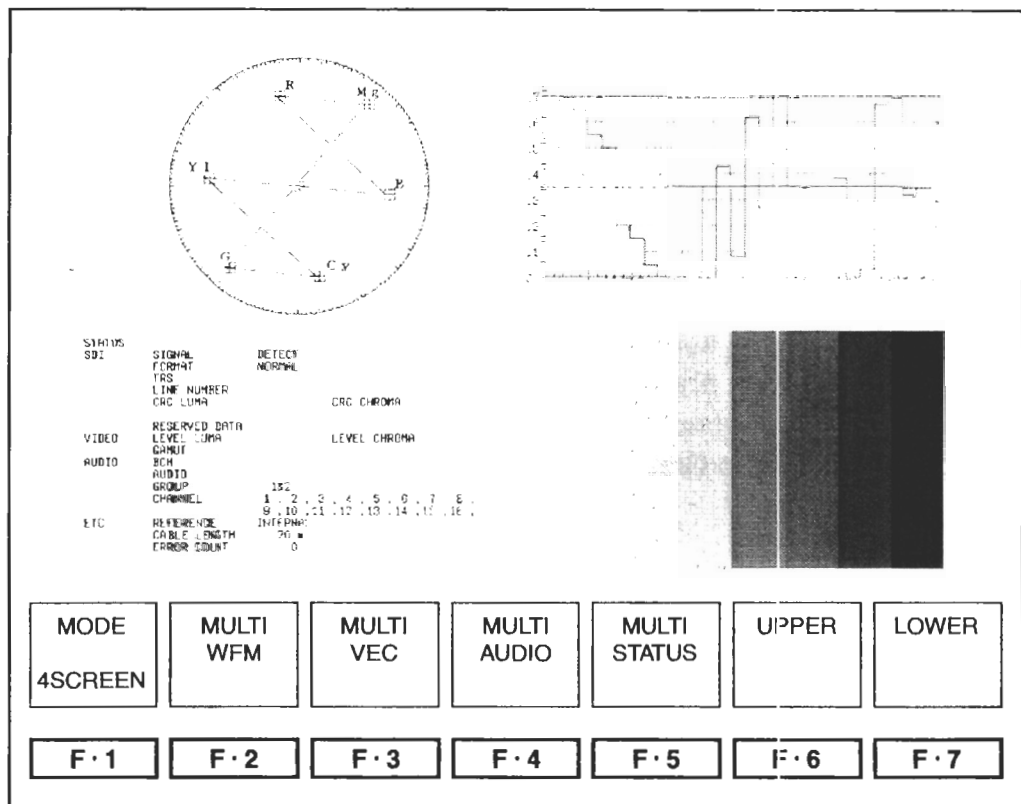

Figure 10.2 Multi screen menu

10.1 Five Multi Screen Modes

[**MULTI**] → [**F.1**] MODE :4SCREEN / WFM_VEC / WFM_PIC / WFM_AUD / WFM_LVL]

The following five modes are available for the multi screen display.

- 4SCREEN:** 4 screen display. The screen is divided into four sections. The upper right quadrant shows the video signal waveform. The lower right shows the picture display. The upper left quadrant shows the vectorscope display or audio waveform. The lower left quadrant shows the audio level meter display or status display.
- WFM_VEC:** Shows the vectorscope and video signal waveform on the left and right sides of the screen, respectively.
- WFM_PIC:** Displays the video signal waveform with the picture at the lower right of the screen.
- WFM_AUD:** Shows the audio waveform and video signal waveform on the left and right sides of the screen, respectively.
- WFM_LVL:** Shows the audio level meter and video signal waveform on the left and right sides of the screen, respectively.

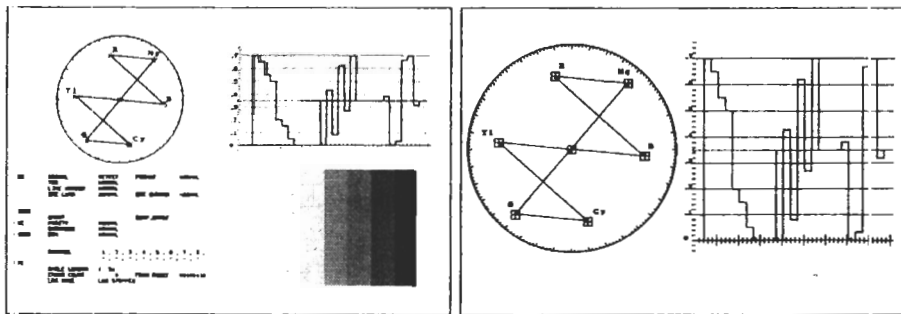

(a) 4 screen multi display

(b) Waveform display and vectorscope display

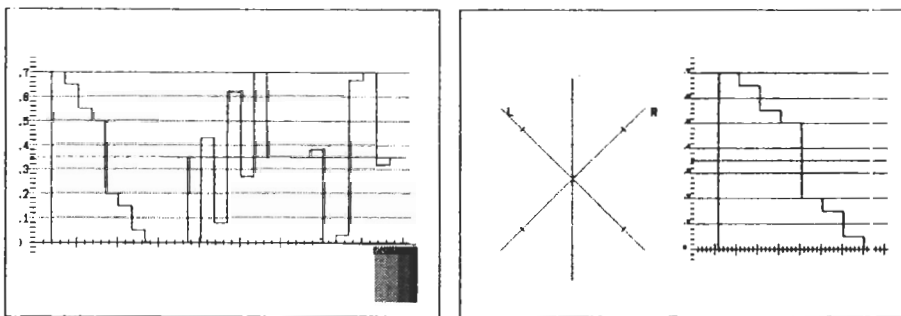

(c) Waveform display and picture display

(d) Waveform display and audio waveform display

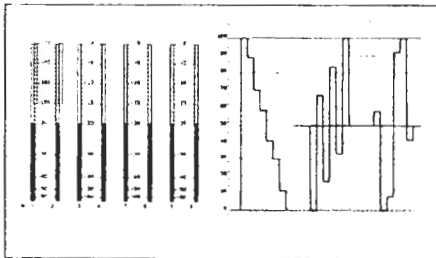

(e) Waveform display and audio level display

Figure 10.3 Five Multi Screen Displays

10.2 Display Content Selection in 4 Screen Mode

[**MULTI**] → [**F.6**] UPPER:VECTOR / AUDIO]

[**MULTI**] → [**F.7**] LOWER:STATUS / AUD_LVL]

On the 4 screen multi display, the video signal waveform is shown in the upper right quadrant and the picture in the lower right quadrant.

You can select the vectorscope waveform or audio waveform for the upper left quadrant, and status or audio level meter for the lower left quadrant.

Press [**F.6**] UPPER of the multi screen menu to select the content to be displayed in the upper left quadrant. Press [**F.7**] LOWER to select the content to be displayed in the lower left quadrant.

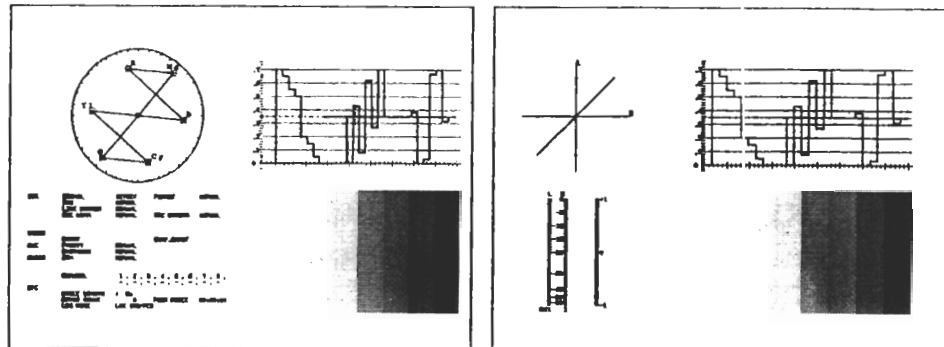

(a) Select vectorscope display and status

(b) Select audio waveform and audio level meter

Figure 10.4 Display content selection of 4 screen display

10.3 Various Settings on the Multi Screen Display

[**F.2**] to [**F.5**] keys on page 1 of the multi screen menu is used to set various display items on the multi screen display.

10.3.1 Video Signal Waveform Display Setting on the Multi Screen Display

[**MULTI**] → [**F.2**] MULTI WFM]

To set items related to the video signal waveform display on the multi screen display, press [**F.2**] MULTI WFM from page 1 of the multi screen menu. The video signal waveform display menu that appears when the WFM key (13) is pressed appears. Enter the appropriate settings.

The settings related to the video signal waveform display on the multi screen display are passed on when the single video signal waveform display is shown.

For a detailed setup procedure, see the items in chapter 6, "Video Signal Waveform Display."

10.3.2 Vectorscope Waveform Display Setting on the Multi Screen Display

[**MULTI**] → [**F.3**] MULTI VEC]

To set items related to the vectorscope display on the multi screen display, press [**F.3**] MULTI VEC from page 1 of the multi screen menu. The vectorscope display menu that appears when the VECTOR key ⑭ is pressed appears. Enter the appropriate settings.

The settings related to the vectorscope display on the multi screen display are passed on when the single vectorscope display is shown.

For a detailed setup procedure, see the items in chapter 7, "Vectorscope Display."

10.3.3 Audio Setting on the Multi Screen Display

[**MULTI**] → [**F.4**] MULTI AUDIO]

To set items related to the audio display on the multi screen display, press [**F.4**] MULTI AUDIO from page 1 of the multi screen menu. The audio display menu that appears when the AUDIO key ⑯ is pressed appears. Enter the appropriate settings.

The settings related to the audio display on the multi screen display are passed on when the single audio display is shown.

For a detailed setup procedure, see the items in chapter 9, "Audio Display."

10.3.4 Status Setting on the Multi Screen Display

[**MULTI**] → [**F.5**] MULTI STATUS]

To set items related to the status display on the multi screen display press [**F.5**] MULTI STATUS from page 1 of the multi screen menu. The status display menu that appears when the STATUS key ⑰ is pressed appears. Enter the appropriate settings.

The settings related to the status display on the multi screen display are passed on when the single status display is shown.

For a detailed setup procedure, see the items in chapter 11, "Status Display."

11. Status Display

The status display can be used to check the status of various parameters of the SDI signal.

Press the STATUS key **17** to display the status screen and the status display menu.

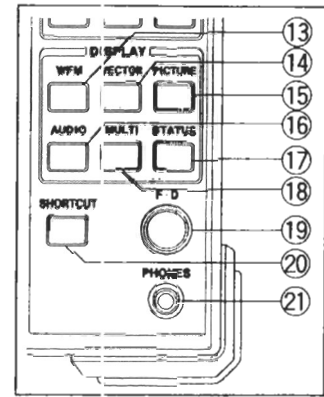

Figure 11.1 Area around the STATUS key **17**

1080i / 59.94 YCbCr [] 2002/05/05 [] 10:00:00						
SDI	SIGNAL	DETECT	FORMAT	NORMAL		
	TRS	NORMAL				
	LINE NUMBER	NORMAL				
	CRC LUMA	NORMAL	CRC CHROMA	NORMAL		
VIDEO	GAMUT	NORMAL	COMP. GAMUT	NORMAL		
ANC	PARITY	NORMAL				
	CHECKSUM	NORMAL				
AUDIO	BCH	NORMAL				
	CHANNEL	1, 2, 3, 4, 5, 6, 7, 8, 9, 10, 11, 12, 13, 14, 15, 16				
ETC	CABLE LENGTH	50m				
	ERROR COUNT	0	FROM RESET	00: 10: 00		
	LOG MODE	NOW LOGGING				
LOG		DATA DUMP		AUDIO		ERROR RESET
F-1		F-2		F-3		F-7
		ANC PACKET		CABLE LENGTH		
		ERROR CONFIG				

Figure 11.2 Status Screen and Status Display Menu

Function Menu	Description
F-1 LOG	Displays the error log.
F-2 DATA DUMP	Displays the data dump.
F-3 AUDIO	Displays the status of the embedded audio.
F-4 ANC PACKET	Displays the ancillary data
F-5 ERROR CONFIG	Displays the error detection setup menu.
F-6 CABLE LENGTH	Selects the cable type on the cable length meter.
F-7 ERROR RESET	Resets the error occurrence such as the error count.

Table 11.1 Description of the Status Display Menu

11.1 Status Display Screen

Press the STATUS key (17) to display the status screen and the status display menu. Below is the description of the status display.

Display Name	Description
SIGNAL	Detects the presence or absence of SDI signals.
FORMAT	Auto detection items of video signal format.
TRS	Detect TRS errors.
LINE NUMBER	Detects line number errors. (only for HD-SDI)
CRC LUMA	Detects Y video signal errors. (only for HD-SDI)
CRC CHROMA	Detects C _B , C _R video signal errors. (only for HD-SDI)
EDH	Detects SD-SDI errors.
GAMUT	Detects Gamut errors.
COMP. GAMUT	Detects level errors when the signal is converted into composite signal.
PARITY	Detects parity errors of ANC data.
CHECKSUM	Detects checksum errors of ANC data.
BCH	Detects embedded audio errors.
CHANNEL	Detects the presence or absence of embedded audio on each channel.
CABLE LENGTH	Converts the SDI signal level into a coaxial cable length and displays the result.
ERROR COUNT	Counts the number of errors up to 100000 errors.
FROM RESET	Time elapsed since error reset.
LOG MODE	Displays the operation status of the error log function.

Table 11.2 Description of the Status Screen Display

11.1.1 Status Indication of SDI Signals

(1) SIGNAL Display

SIGNAL on the status display screen indicates whether the SDI signal exists at the input connector.

The presence/absence of SDI signals is detected by the lock/unlock condition of the internal reclocker. If the amplitude of the SDI signal is small or if the amount of jitter is large, the indicator may show NO SIGNAL even when a signal is being applied.

DETECT: The presence of the SDI signal is confirmed.

NO SIGNAL: The SDI signal cannot be detected.

(2) Format Display

If auto selection of the video signal is enabled in section 5.4.1, "Auto/Manual Selection," the FORMAT indication on the status display screen shows whether the video format of the input SDI signal can be monitored on the LV 5750.

If manual selection is used, it shows whether the selected video format is being input.

For both auto selection and manual selection, the current video format is shown at the upper right corner of the screen.

FORMAT indication

When the video format selection is set to AUTO

NORMAL: A signal of a video format that can be monitored on the LV 5750 is being input.

UNKNOWN: A signal of a video format that cannot be monitored on the LV 5750 is being input.

When the video format selection is set to MANUAL

NORMAL: The video format selected manually is being input.

UNKNOWN: A video format other than the one selected manually is being input.

(3) TRS Display

TRS on the status display screen can be used to detect errors in the TRS (Timing Reference Signal) of the input SDI signal.

TRS error detects whether the EAV (End of Active Video) and SAV (Start of Active Video) positions in the SDI signal are in the correct place.

To detect TRS errors, error detection in section 11.6.3, "Detection ON/OFF of Errors" must be turned ON.

TRS indication

NORMAL: The TRS in the SDI signal is normal.

ERROR: There is an error in the TRS in the SDI signal.

Blank: TRS errors in the SDI signal are not being detected.

(4) Line Number Display

LINE NUMBER on the status display screen indicates whether the line number multiplexed in the input HD-SDI signal matches the number of lines that is being counted internally by the LV 5750.

Since the line number is multiplexed only in HD-SDI signals, it is not indicated for SD-SDI signals.

To detect line number errors, error detection in section 11.6.3, "Detection ON/OFF of Errors" must be turned ON.

LINE NUMBER indication

NORMAL: The line number in the HD-SDI signal is normal.

ERROR: There is an error in the line number in the HD-SDI signal.

Blank: Line number errors in the HD-SDI signal are not being detected.

(5) CRC LUMA and CRC CHROMA Display

CRC LUMA and CRC CHROMA on the status display screen indicate whether the CRC multiplexed in the input HD-SDI signal matches the CRC result that is calculated internally by the LV 5750 for the intensity signal and the chrominance difference signal separately.

Since the CRC is multiplexed only in HD-SDI signals, it is not indicated for SD-SDI signals.

To detect CRC errors, error detection in section 11.6.3, "Detection ON/OFF of Errors" must be turned ON.

CRC LUMA indication

NORMAL: The CRC of the intensity signal in the HD-SDI signal is normal.

ERROR: There is an error in the CRC of the intensity signal in the HD-SDI signal.

Blank: CRC errors in the HD-SDI signal are not being detected.

CRC CHROMA indication

NORMAL: The CRC of the chrominance difference signal in the HD-SDI signal is normal.

ERROR: There is an error in the CRC of the chrominance difference signal in the HD-SDI signal.

Blank: CRC errors in the HD-SDI signal are not being detected.

(6) EDH Display

EDH on the status display screen indicates whether an error occurred in the EDH that is multiplexed in the input SD-SDI signal. An error occurs when the error flag of the received EDH packet is 1 (error somewhere in the SDI transmission path) or when the CRC in the EDH packet does not match the CRC value calculated in the LV 5750.

Since the EDH is multiplexed only in SD-SDI signals, it is not indicated for HD-SDI signals.

To detect EDH errors, error detection in section 11.6.3, "Detection ON/OFF of Errors" must be turned ON.

For details on the EDH error, see section 11.5.1, "EDH Status Display."

EDH indication

NORMAL: The EDH in the SD-SDI signal is normal.

ERROR: There is an error in the EDH in the SD-SDI signal.

NOT FOUND: The EDH in the SD-SDI signal cannot be found.

Blank: EDH errors in the SD-SDI signal are not being detected.

11.1.2 Status Display of Ancillary Data

(1) Parity Display

PARITY on the status display screen indicates the result of the error detection using the parity bit included in the header section of the ancillary data in the applied SDI signal.

The parity error detection does not detect errors in the UDW (user data word) section.

To detect parity errors, error detection in section 11.6.3, "Detection ON/OFF of Erros" must be turned ON.

PARITY indication

NORMAL: The parity of the ancillary data is normal.

ERROR: Parity error occurred in the ancillary data.

(2) Checksum Display

CHECKSUM on the status display screen indicates the result of the error detection using the checksum included in the ancillary data in the applied SDI signal.

To detect checksum errors, error detection in section 11.6.3, "Detection ON/OFF of Erros" must be turned ON.

CHECKSUM indication

NORMAL: The checksum of the ancillary data is normal.

ERROR: Checksum error occurred in the ancillary data.

11.1.3 Status Display of the Video Signal Level

(1) Gamut Display

GAMUT on the status display screen indicates whether gamut errors have occurred.

You can set upper and lower limits for the gamut error detection values.

To detect gamut errors, error detection in section 11.6.3, "Detection ON/OFF of Erros" must be turned ON.

For the procedure in setting the gamut error detection values, see section 11.7.1, "Gamut Error Threshold Level".

GAMUT indication

NORMAL: The upper and lower limits do not exceed the specified level.

ERROR: The specified level is exceeded.

Blank: Gamut errors are not being detected.

(2) Composite Gamut Display

COMP. GAMUT on the status display screen indicates whether level errors have occurred when the signal was converted into composite signal.

Signals that meet the prescribed levels as Y, C_B, C_R signals may exceed the prescribed levels when converted to composite signal. Composite gamut error monitors the level using the signal converted to composite signal.

You can set upper and lower limits for the composite gamut error detection values.

To detect composite gamut errors, the composite gamut error detection in section 11.6.3, "Detection ON/OFF of Errors" must be turned ON.

For the procedure in setting the threshold levels of composite gamut errors, see section 11.7.2, "Composite Gamut Error Threshold Level".

COMP. GAMUT indication

NORMAL: The specified upper and lower limits are not exceeded after converting to a composite signal.

ERROR: The specified level is exceeded after converting to a composite signal.

Blank: Composite gamut errors are not being detected.

11.1.4 Status Display of Embedded Audio

(1) BCH Display

BCH on the status display screen indicates errors in the BCH code of the embedded audio that is multiplexed in the HD-SDI signal.

Since the BCH is multiplexed only in HD-SDI signals, it is not indicated for SD-SDI signals.

The LV 5750 does not have an error correction function. Therefore, errors will not be corrected even when BCH errors occur.

To detect BCH errors, error detection in section 11.6.3, "Detection ON/OFF of Errors" must be turned ON.

BCH indication

NORMAL: BCH error is not occurring in the embedded audio.

ERROR: BCH error occurred in the embedded audio.

Blank: BCH errors in the embedded audio are not being detected.

(2) Channel Display

CHANNEL on the status display screen indicates embedded audio channels that are multiplexed in the SDI signal.

The multiple channel display can show all 16 channels as defined by the standard.

The presence of each embedded audio channel is detected by monitoring the voice control packets. If the voice control packet flag is not valid, multiplexed channels are not indicated even if embedded audio packets are multiplexed in the SDI signal

CHANNEL indication

-: Embedded audio is not multiplexed.

Value: Audio channels corresponding to the indicated values are multiplexed.

11.1.5 Other Status Displays

(1) Cable Display

CABLE LENGTH on the status display indicates the attenuation by converting the attenuation of the input SDI signal to an equivalent cable length by assuming the SDI signal intensity reference to be 800 mV.

① For HD-SDI signals

The equivalent cable length measurement for HD-SDI signals converts the signal attenuation to an LS-5CFB, L-7CHD or 1694A cable length.

Select the type of cable length to be converted into in section 11.9.1, "HD-SDI Cable Selection."

The display range is as follows:

• LS-5CFB and 1694A

<5 m, 5 m, ..., 125 m, >130 m The display resolution is 5 m.

• L-7CHD

<10 m, 10 m, ..., 200 m, >200 m The display resolution is 10 m.

② For SD-SDI signals

The equivalent cable length measurement for SD-SDI signals converts the signal attenuation to a 5C2V, 8281, or 1505A cable length.

Select the type of cable length to be converted into in section 11.9.2, "SD-SDI Cable Selection."

The display range is as follows:

<50 m, 50 m, ..., 295 m, >300 m The display resolution is 5 m.

(2) Error Count Indication

ERROR COUNT on the status display indicates the number of detected errors. The indication range is between 0 and 100,000. You can switch the error count indication to a mode that counts once per second or a mode that counts once per field. For details, see section 11.6.2, "Error Count Rate Setting."

(3) Elapsed Time since Error Reset

FROM RESET on the status display indicates the current elapsed time since error reset.

The built-in realtime clock is used to display the elapsed time.

(4) Error Log Mode Display

LOG MODE on the status display indicates the operation status of the error log function.

You can select the error log operation in section 11.2.2, "Event Log Start/Stop."

LOG MODE indication

NOW LOGGING: Error log function is enabled.

LOG STOPPED: Error log function is disabled.

11.2 Event Log

Select **F.1** LOG from the status display screen to show a log list display of error detection information.

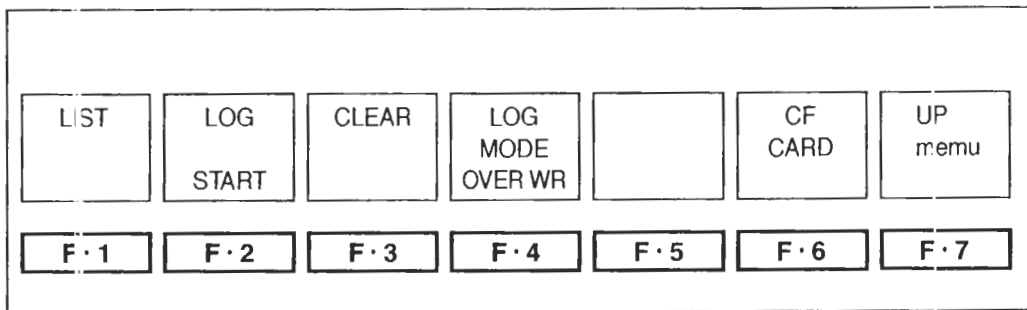

Figure 11.3 Event log display menu

11.2.1 Event log list display

[**STATUS**] → [**F.1**] LOG]

Select [**F.1**] LOG from the status display menu that appears by pressing the STATUS key (F17) to show the event log list.

The event log handles consecutive errors of the same type as a single log incident. Up to 1,000 errors can be stored in the log.

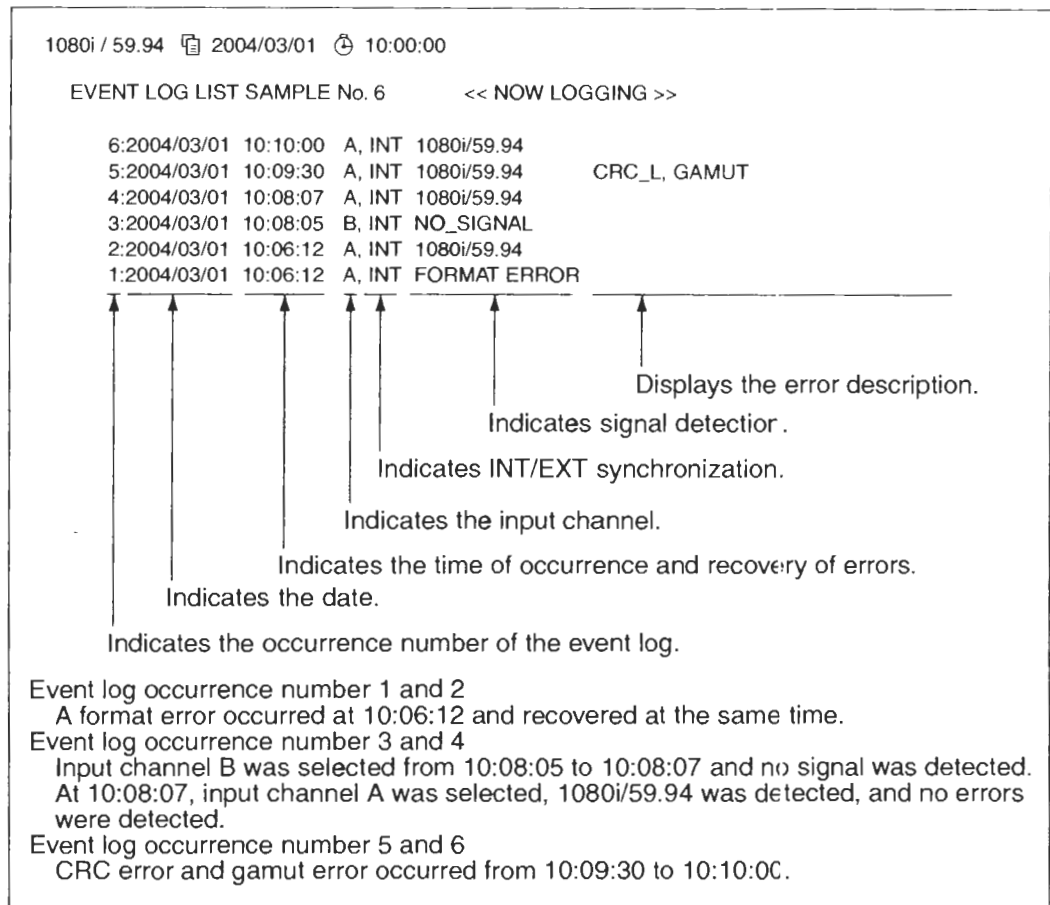

Figure 11.4 Event Log Display

Error information display

The error information column in the event log only takes the log of the items whose error detection has been turned ON.

The error items are displayed using abbreviations. See the table below for the abbreviations and the error detection information.

The event log records one event per line. If multiple errors occur simultaneously, all the errors cannot be displayed. If this happens, you can save the errors to a compact flash memory card as text and view all the error items.

Abbreviation	Error Description
TRS	TRS error
LINE	HD-SDI line number error
CRC_L	HD-SDI Y video signal transmission error
CRC_C	HD-SDI C _B , C _R video signal transmission error
EDH	SD-SDI transmission error
GMUT	Gamut error
CGMUT	Level error when the signal is converted into composite signal
PRTY	Ancillary data parity error
CHK	Ancillary data checksum error
BOH	Embedded audio transmission error
CABL	Cable length error

Table 11.3 Abbreviations in the event log

11.2.2 Starting/Stopping the Event Log

[**STATUS**] → [**F.1**] LOG → [**F.2**] LOG : START / STOP]

To start or stop the event log, press [**F.2**] LOG from the event log display menu to select START or STOP.

11.2.3 Clearing the Event Log

[**STATUS**] → [**F.1**] LOG → [**F.3**] CLEAR]

To clear the event log, press [**F.3**] CLEAR from the event log display menu.

If you clear the event log, the error count on the status display is reset to 0, and all errors are cleared.

11.2.4 Log Operation Mode

[**STATUS**] → [**F.1**] LOG → [**F.4**] LOG MODE: OVER WR / STOP]

Up to 1000 items can be recorded in the event log.

You can select the operation when the log exceeds 1000 items. You can select to overwrite old logs or stop logging when 1000 items have been recorded.

To select the log operation mode, press [**F.4**] LOG MODE from the event log display menu and select OVER WR (for overwrite) or STOP.

11.2.5 Storage to the Compact Flash Card

The event log can be stored to a compact flash card as a text data. The procedure is indicated below.

* Use FAT16 for the file system on the compact flash card.

Writing is not possible on other file systems such as FAT32 and NTFS.

- ① Showing the save menu to the compact flash card
 [STATUS] → [F.1] LOG → [F.6] CF CARD]
 Press [F.6] CF CARD from the event log display menu to show the compact flash card save menu.

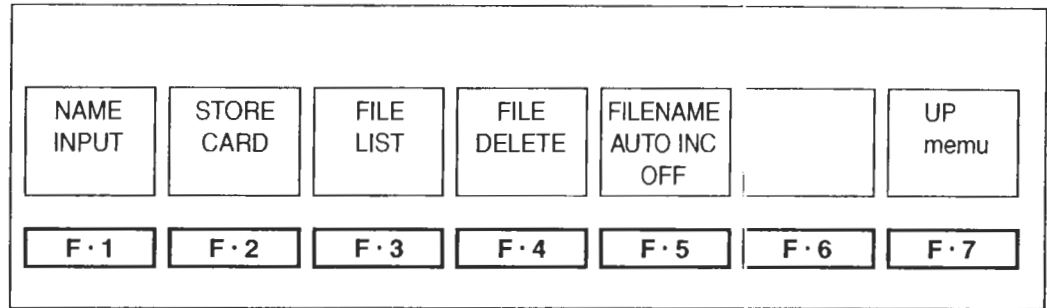

Figure 11.5 Compact Flash Card Save Menu

- ② Specifying the file name
 [STATUS] → [F.1] LOG → [F.6] CF CARD → [F.1] NAME INPUT]
 From the compact flash card storage menu, press [F.1] NAME INPUT to show the file name entry screen.
 Enter the file name using the function key ([F.1] to [F.7]) ② and the function dial ([F.D]) ①. After you finish entering the file name, press [F.7] up menu. If a space is included in the file name, it is converted to an underscore.

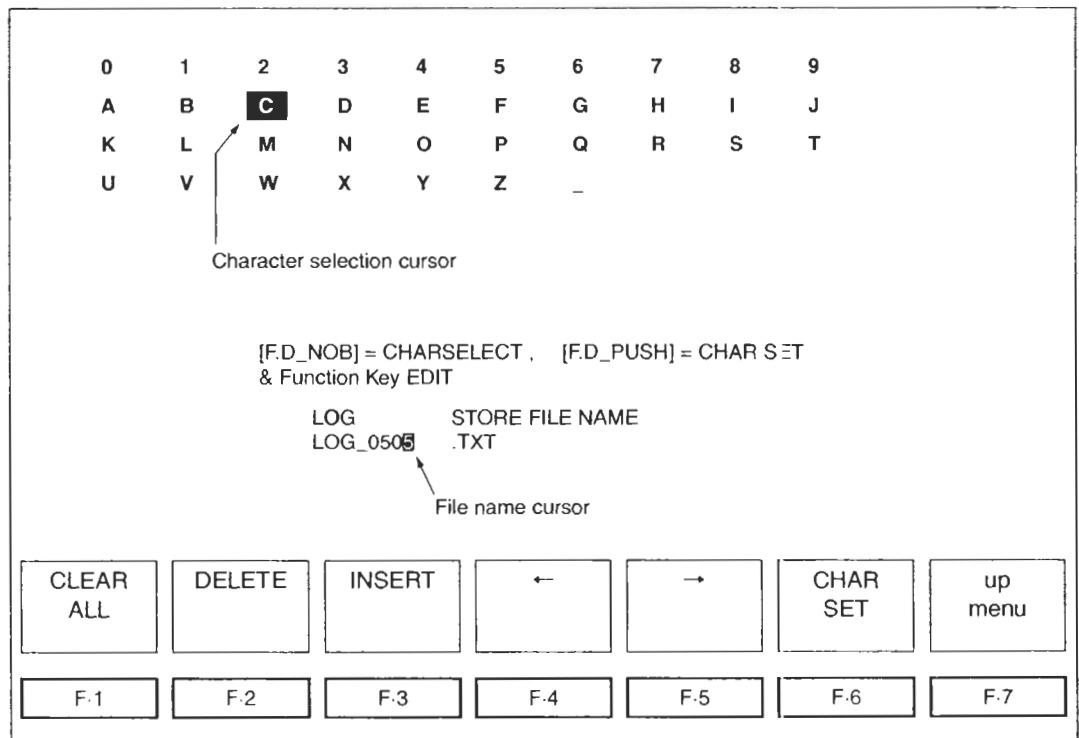

Figure 11.6 File name entry screen

Function Key	Description
F-1 CLEAR ALL	Clears the file name
F-2 DELETE	Clears the character at the file name cursor
F-3 INSERT	Enter a single space at the file name cursor
F-4 ←	Moves the file name cursor to the left by a character
F-5 →	Moves the file name cursor to the right by a character
F-6 CHAR SET	Applies the character at the character selection cursor to the file name.
F-7 up menu	Confirms the file name

Table 11.4 File Name Entry Menu

③ Saving the event log to the card

[[STATUS] → [F-1] LOG → [F-6] CF CARD → [F-2] STORE CARD]

Check that a compact flash card is inserted in the dedicated interface card for the LV 5750. (The interface card is inserted in the external IF slot ②4 on the rear panel.) Then press [F-2] STORE CARD.

The event log is saved to the compact flash card as a text file.

If a compact flash card is not inserted in the dedicated interface card, a message "No Card In Slot" is displayed.

If a text file with the same name already exists on the compact flash card, [F-1] OVER WR YES, [F-3] OVER WR NO appears. Press the [F-1] key to overwrite the file and [F-3] key to cancel.

After the writing of the event log is complete, a file list of the compact card is displayed.

The file list only displays the event log text files.

11.2.6 File List of the Compact Flash Card

[[STATUS] → [F-1] LOG → [F-6] CF CARD → [F-3] FILE LIST]

To display the file list of the compact flash card, press [F-3] FILE LIST from the compact flash card storage menu. The file list only displays the event log text files.

If a compact flash card is not inserted in the dedicated interface card, a message "No Card In Slot" is displayed.

11.2.7 Log File Deletion

[[STATUS] → [F-1] LOG → [F-6] CF CARD → [F-4] FILE DELETE]

To delete an event log file, press [F-4] FILE DELETE from the compact flash card save menu. If you then press [F-1] DELETE YES, the selected log file is deleted. If you press [F-3] DELETE NO, the file is not deleted, and the screen returns to the compact flash card save menu.

11.2.8 Auto Increment of File Names

[**STATUS**] → [**F.1**] LOG → [**F.6**] CF CARD → [**F.5**] FILENAME AUTO INC : ON / OFF]

A number can be added automatically to the file name of data stored to the compact flash memory card.

11.3 Data Dump Display

Select [**F.2**] DATA DUMP from the status display menu to show the data dump display screen. The data dump of the selected line and the data dump display menu are displayed.

1080i / 59.94				2004/03/01		10:00:00	
	DATA DUMP LINE #	1					
	SAMPLE	Y	Cb/Cr				
[EAV]	<1920>	3FF	3FF				
[EAV]	<1921>	000	000				
[EAV]	<1922>	000	000				
[EAV]	<1923>	2D8	2D8				
	<1924>	204	204				
	<1925>	200	200				
	<1926>	2BB	2F7				
	<1927>	23C	1E8				
	<1928>	040	200				
	<1929>	040	200				
	<1930>	040	200				
	<1931>	040	200				
	<1932>	040	200				
	<1933>	040	200				
	<1934>	040	200				
	<1935>	040	200				
MODE	DISPLAY	EAV	SAV	F.D	CF	up	
RUN	SERIAL	JUMP	JUMP	LINE	CARD	menu	
F.1	F.2	F.3	F.4	F.5	F.6	F.7	

Figure 11.7 Data dump display and data dump display menu

11.3.1 Data Dump Display Auto Updating and Hold

[**STATUS**] → [**F.2**] DATA DUMP → [**F.1**] MODE : RUN / HOLD]

The data dump display can be automatically updated or held. From the data dump display menu, press [**F.1**] MODE to select RUN to automatically update the data dump or select HOLD to hold the data dump.

11.3.2 Data Dump Display Format Selection

[[STATUS] → [F-2] DATA DUMP → [F-2] DISPLAY:SERIAL / COMPO / BINARY]

There are three methods of displaying data dumps: serial display which displays the serial data array after parallel conversion, composite display which displays components individually for each waveform channel, and binary display. In the serial data array method, the intensity signal (Y) and chrominance difference signal (C_B, C_R) are displayed separately for HD-SDI signals.

- SERIAL:** Displays the data dump using a serial data array after parallel conversion.
- COMPONENT:** Displays the data dump using a serial data array after parallel conversion that has been separated into Y, C_B, C_R.
- BINARY:** Displays the data dump using a serial data array after parallel conversion in binary notation.

1080i / 59.94 2004/03/01 10:00:00			
DATA DUMP LINE #	1		
	SAMPLE	Y	Cb/Cr
[EAV]	<1920>	3FF	3FF
[EAV]	<1921>	000	000
[EAV]	<1922>	000	000
[EAV]	<1923>	2D8	2D8
	<1924>	204	204
	<1925>	200	200
	<1926>	2BB	2F7
	<1927>	23C	1E8
	<1928>	040	200
	<1929>	040	200
	<1930>	040	200
	<1931>	040	200
	<1932>	040	200
	<1933>	040	200
	<1934>	040	200
	<1935>	040	200

(a) HD-SDI serial data array display

1080i / 59.94 2004/03/01 10:00:00				
DATA DUMP LINE #	1			
	SAMPLE	Y	Cb	Cr
[EAV]	<1920>	3FF	3FF	
[EAV]	<1921>	000		000
[EAV]	<1922>	000	000	
[EAV]	<1923>	2D8		2D8
	<1924>	204	204	
	<1925>	200		200
	<1926>	2BB	2F7	
	<1927>	23C		1E8
	<1928>	040	200	
	<1929>	040		200
	<1930>	040	200	
	<1931>	040		200
	<1932>	040	200	
	<1933>	040		200
	<1934>	040	200	
	<1935>	040		200

(b) HD-SDI component display

625i / 50 2004/03/01 10:00:00			
DATA DUMP LINE #	1		
	SAMPLE	COLOR	DATA
[EAV]	< 720>	Cb	3FF
[EAV]	< 721>	Y	000
	< 722>	Cr	000
	< 723>	Y'	2D8
	< 724>	Cb	000
	< 725>	Y	3FF
	< 726>	Cr	3FF
	< 727>	Y'	2FF
	< 728>	Cb	2C0
	< 729>	Y	224
	< 730>	Cr	290
	< 731>	Y'	20D
	< 732>	Cb	21F
	< 733>	Y	292
	< 734>	Cr	20D
	< 735>	Y'	11F

(c) SD-SDI serial data array display

625i / 50 2004/03/01 10:00:00				
DATA DUMP LINE #	1			
	SAMPLE	Y	C.ADR	Cb Cr
[EAV]	< 720>	0	<360>	3FF 000
[EAV]	< 721>	2D8		
[EAV]	< 722>	3FF	<361>	000 3FF
[EAV]	< 723>	2FF		
	< 724>	224	<362>	224 290
	< 725>	20D		
	< 726>	292	<363>	21F 20D
	< 727>	11F		
	< 728>	20D	<364>	294 11F
	< 729>	296		
	< 730>	21F	<365>	20D 170
	< 731>	1BC		
	< 732>	172	<366>	21E 1BC
	< 733>	11E		
	< 734>	1BC	<367>	174 11E
	< 735>	176		

(d) SD-SDI component display

1080i / 59.94 2004/03/01 10:00:00			
DATA DUMP	LINE #	1	
[EAV]	SAMPLE	Y	Cb/Cr
<1920>	1111111111	1111111111	1111111111
<1921>	0000000000	0000000000	0000000000
<1922>	0000000000	0000000000	0000000000
<1923>	1011011000	1011011000	1011011000
<1924>	1000000100	1000000100	1000000100
<1925>	1000000000	1000000000	1000000000
<1926>	1010111011	1011110111	1011110111
<1927>	1000111100	0111101000	0111101000
<1928>	0001000000	1000000000	1000000000
<1929>	0001000000	1000000000	1000000000
<1930>	0001000000	1000000000	1000000000
<1931>	0001000000	1000000000	1000000000
<1932>	0001000000	1000000000	1000000000
<1933>	0001000000	1000000000	1000000000
<1934>	0001000000	1000000000	1000000000
<1935>	0001000000	1000000000	1000000000

(e) Binary display

Figure 11.8 Data dump display format of SDI signals

11.3.3 Auto Search of EAV/SAV

[**STATUS**] → [**F.2**] DATA DUMP → [**F.3**] EAV JUMP]
 [**STATUS**] → [**F.2**] DATA DUMP → [**F.4**] SAV JUMP]

You can select whether to display the start sample number of the data dump display using the EAV sample number or SAV sample number. Press [**F.3**] EAV JUMP from the data dump display menu to display the data dump from the EAV sample number; press [**F.4**] SAV JUMP to display the data dump from the SAV sample number.

11.3.4 Line Number and Sample Number Selection

[**STATUS**] → [**F.2**] DATA DUMP → [**F.5**] F.D: LINE / SAMPLE]

To change the line number or sample number of the data dump display, turn the function dial (**F.D**) ①. If [**F.5**] F.D is set to the LINE, the line number is varied. If [**F.5**] F.D is set to SAMPLE, the sample number is varied.

LINE: Sets the range of lines that can be selected using the function dial (**F.D**) ① to the entire frame.

SAMPLE: Selects the sample number of the line specified using the function dial (**F.D**) ①.

11.3.5 Storage to the Compact Flash Card

The selected one line of the data dump can be saved to the compact flash card. The procedure is indicated below.

* Use FAT16 for the file system on the compact flash card.

Writing is not possible on other file systems such as FAT32 and NTFS.

① Showing the save menu to the compact flash card

[**[STATUS]** → **[F.2]** DATA DUMP → **[F.6]** CF CARD]

Press **[F.6]** CF CARD from the data dump display menu to show the compact flash card save menu.

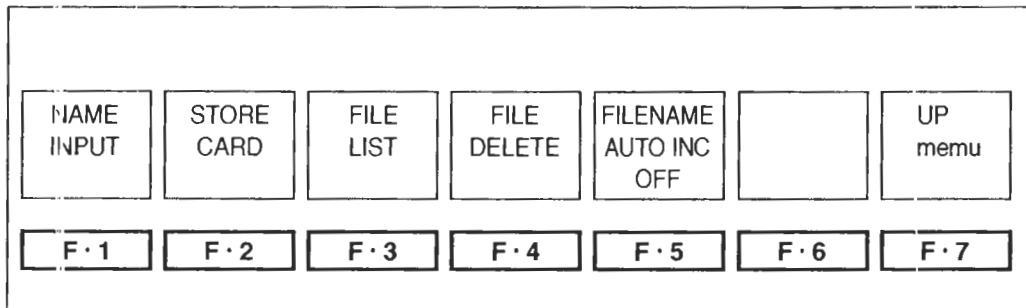

Figure 11.9 Compact Flash Card Save Menu

② Specifying the file name

[**[STATUS]** → **[F.2]** DATA DUMP → **[F.6]** CF CARD → **[F.1]** NAME INPUT]

From the compact flash card save menu, press **[F.1]** NAME INPUT to show the file name entry screen.

Enter the file name using the function key (**[F.1]** to **[F.7]**) ② and the function dial (**[F.D]**) ⑱. After you finish entering the file name, press **[F.7]** up menu. If a space is included in the file name, it is converted to an underscore.

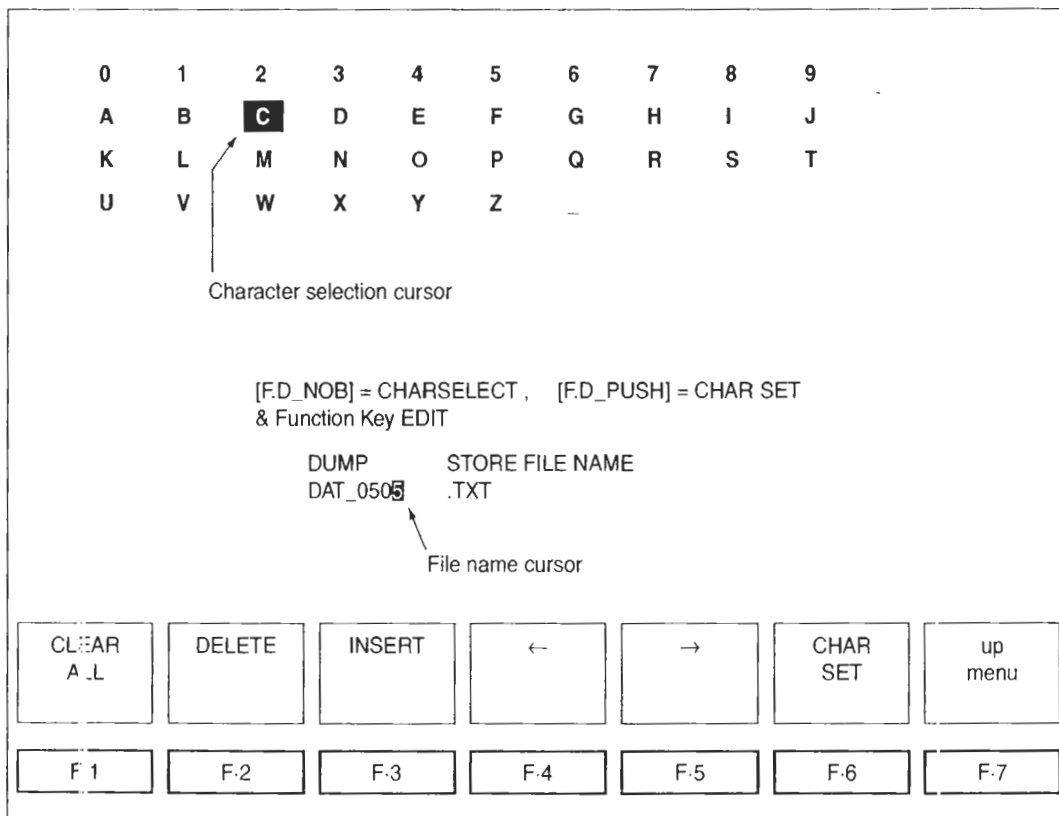

Figure 11.10 File name entry screen

Function Key	Description
F-1 CLEAR ALL	Clears the file name
F-2 DELETE	Clears the character at the file name cursor
F-3 INSERT	Enter a single space at the file name cursor
F-4 ←	Moves the file name cursor to the left by a character
F-5 →	Moves the file name cursor to the right by a character
F-6 CHAR SET	Applies the character at the character selection cursor to the file name.
F-7 up menu	Confirms the file name

Table 11.5 File Name Entry Menu

③ Saving the data dump to the card

[**STATUS** → **F-2** DATA DUMP → **F-6** CF CARD → **F-2** STORE CARD]

Check that a compact flash card is inserted in the dedicated interface card for the LV 5750. (The interface card is inserted in the external IF slot ② on the rear panel.) Then press **F-2** STORE CARD.

The data dump is saved to the compact flash card as a text file.

If a compact flash card is not inserted in the dedicated interface card, a message "No Card In Slot" is displayed.

If a text file with the same name already exists on the compact flash card, **F-1** OVER WR YES, **F-3** OVER WR NO appears. Press the **F-1** key to overwrite the file and **F-3** key to cancel.

After the writing of the data dump is complete, a file list of the compact card is displayed.

The file list only displays the data dump text files.

11.3.6 File List of the Compact Flash Card

[**STATUS** → **F-2** DATA DUMP → **F-6** CF CARD → **F-3** FILE LIST]

To display the file list of the compact flash card, press **F-3** FILE LIST from the compact flash card save menu. The file list only displays the text files of the data dump.

If a compact flash card is not inserted in the dedicated interface card, a message "No Card In Slot" is displayed.

11.3.7 Data Dump File Deletion

[**STATUS** → **F-2** DATA DUMP → **F-6** CF CARD → **F-4** FILE DELETE]

To delete a data dump file, press **F-4** FILE DELETE from the compact flash card save menu. If you then press **F-1** DELETE YES, the selected data dump file is deleted. If you press **F-3** DELETE NO, the file is not deleted, and the screen returns to the compact flash card save menu.

11.4 Status Display of Embedded Audio

The LV 5750 enables you to view the bit corresponding to the channel status bit of the AES/EBU audio packet in the embedded audio signal multiplexed in the SDI signal. However, the bit is not displayed when the format is type II data format (consumer mode).

You can display the channel status bit by selecting any channel from the 8 channels of audio signals of 2 groups that were selected in section 9.2, "Embedded Audio Group Selection."

Press **[F-3] AUDIO** from the status display screen to display the detailed status of embedded audio and the channel selection menu.

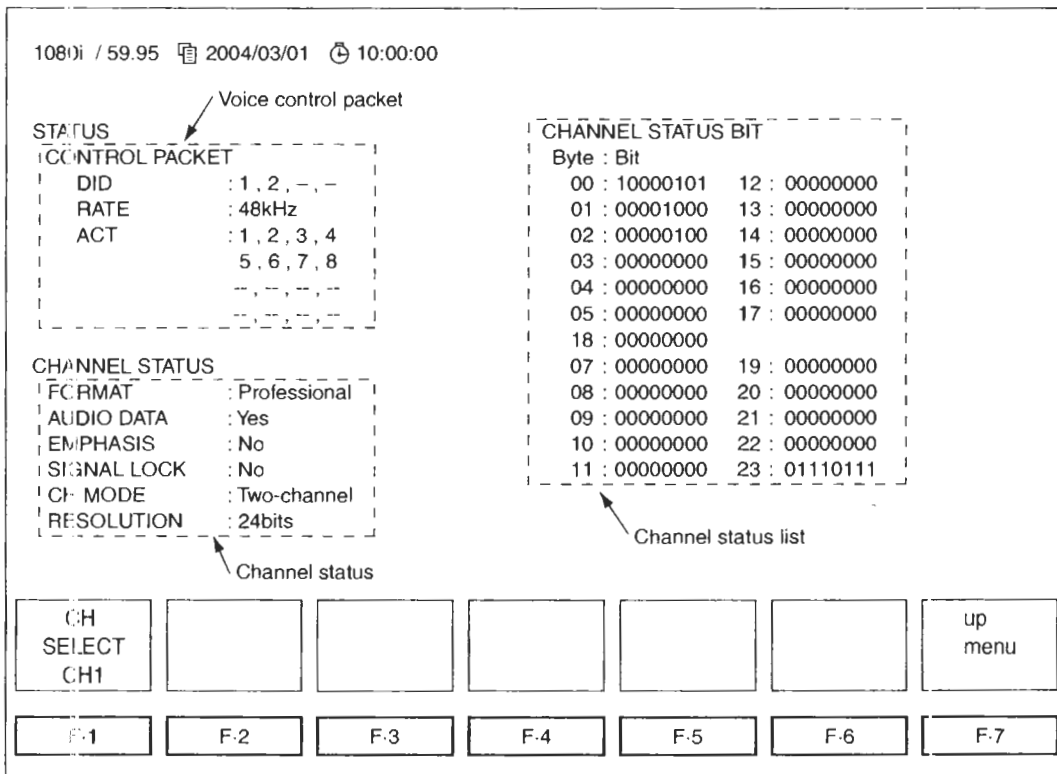

Figure 11.11 Detailed status display of embedded audio

11.4.1 Channel Selection

You can switch the audio channel on the channel status display using **[F-1] CH SELECT**.

The channels that you can select are determined by the selection you make in section 9.2, "Embedded Audio Group Selection."

For details, see section 9.2, "Embedded Audio Group Selection."

11.4.2 Voice Control Packets

For HD-SDI, the voice control packets are normally multiplexed in line 9 or line 571 (interlace only) of the horizontal ancillary data area of the Y channel. For 525i/59.94, the packets are multiplexed in line 12 and line 275 of the horizontal ancillary data area. For 625i/50, the packets are multiplexed in line 8 and line 321. However, if the sampling frequency of the audio signal is 48 kHz, voice control packets do not need to be multiplexed.

The voice control packet display shows the following information from the data multiplexed in the SDI signal as text.

DID indication

Checks the DID of the voice control packets that are multiplexed in the SDI signal and displays the multiplexed audio groups.

Value: The audio groups indicated by the values are multiplexed.

-: Audio group that is not multiplexed.

ACT indication

Checks the ACT of voice control packets and displays the audio channels that are multiplexed in the SDI signal as embedded audio.

Value: The audio channels indicated by the values are multiplexed.

-: Audio channel that is not multiplexed.

RATE indication

Check the RATE of voice control packets and displays the sampling frequency of the selected audio group.

11.4.3 Channel Status

The channel status of the detailed status display of embedded audio shows information by analyzing the channel status bit of embedded audio packets.

FORMAT indication

Indicates whether the signal is an audio signal for the broadcasting studio or a signal for consumer audio devices or the like.

Professional: Indicates that the signal is for the broadcasting studio.

Consumer: Indicates that the signal is for consumer audio devices or audio software manufacturing.

AUDIO DATA indication

Indicates whether the audio packet is an audio signal or data other than the audio signal.

Yes: Audio signal

No: Signal other than audio

EMPHASIS indication

Indicates the audio signal emphasis setting.

Not_indicated: No emphasis indication

No: No emphasis

50/15us: Emphasis time constant of 50/15 μ s

CCIT_J17: CCITT J.17 (800 Hz insertion loss of 6.5 dB)

Reserved: Received undefined data

SIGNAL LOCK indication

Lock condition of the source sampling frequency

Yes: Locked

No: Not locked

CH MODE indication

Indicates channel mode setting.

Not_indicated: No mode indication

Two-channel: 2 channel mode

Single-channel: 1 channel mode

Primary/secondary: Primary/Secondary mode

Stereo: Stereo mode

Reserved: Received undefined data

RESOLUTION indication

Indicates quantization accuracy.

24bits: Indicates audio data of 24-bit quantization accuracy.

20bits: Indicates audio data of 20-bit quantization accuracy.

11.4.4 Channel Status List Display

The channel status list of the detailed status display of embedded audio shows all 192 bits of the channel status of embedded audio packets.

11.5 Ancillary Data Display

The LV 5750 can display the analyzed results of the ancillary data that is multiplexed in the SDI signal. Press **[F.4]** ANC PACKET from the status display menu to show the ancillary data display menu.

However, for audio control packets, check the data as described in section 11.1.4, "Status Display of Embedded Audio."

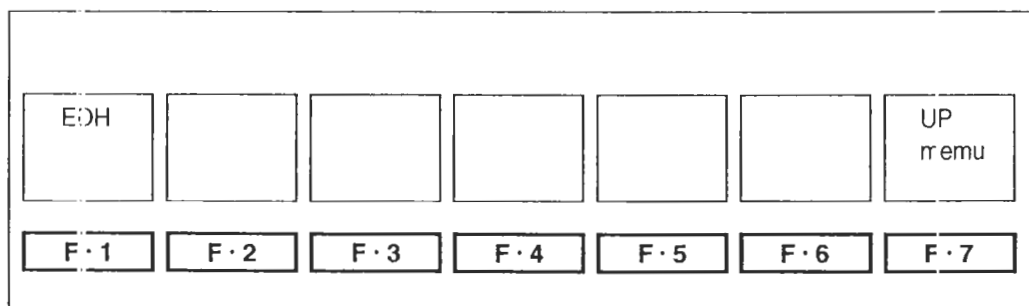

Figure 11.12 Ancillary data display menu

11.5.1 EDH Status Display

In the case of SD-SDI signals, [F.4] EDH is displayed in the status display menu, the detailed EDH status can be displayed.

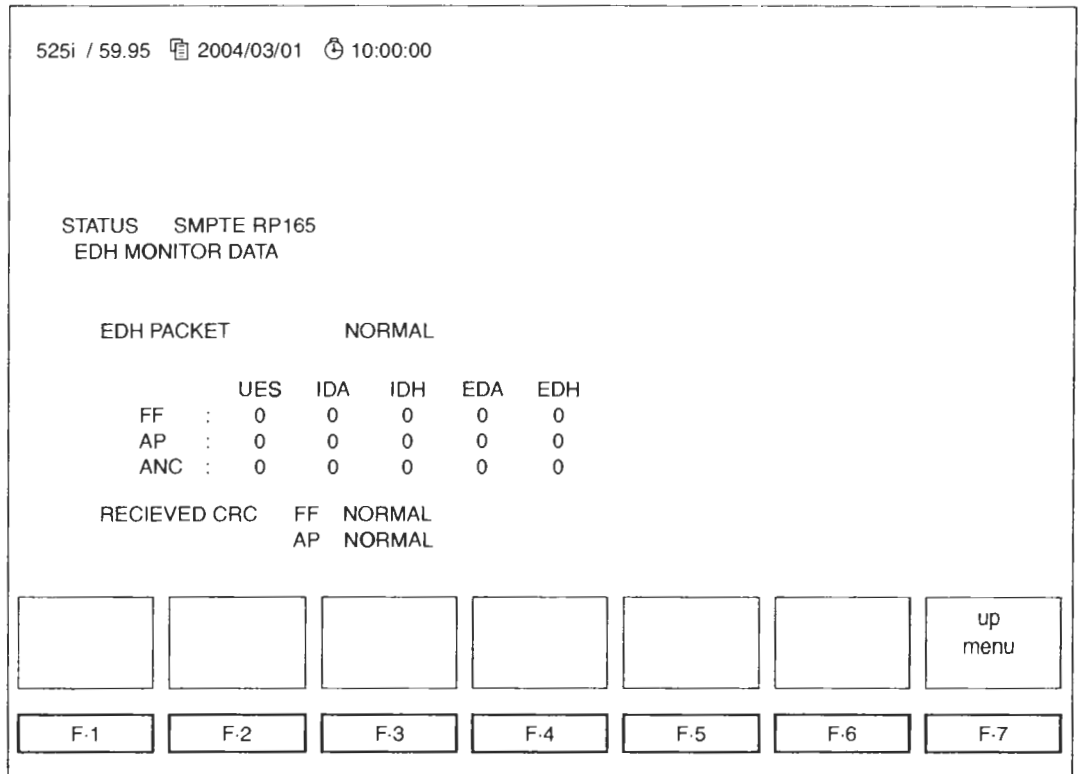

Figure 11.13 Detailed EDH status display

The EDH packet flag indicates the contents of the EDH packet that is multiplexed in the input SDI signal. RECEIVED CRC indicates the result of the comparison between the CRC in the EDH packet and the CRC calculated from the data.

Because the SDI output is delivered by passing through only the serial reclock circuit, the packet contents are not overwritten even if an error occurs in the RECEIVED CRC.

The details of each flag are shown below.

- FF: Full field. A CRC code is generated from all the data in a single field, and the result of the error detection is displayed.
- AP: Active picture. A CRC code is generated from the data in the active video period, and the result of the error detection is displayed.
- ANC: Ancillary data. A parity bit and checksum are generated from the ancillary data, and the result of the error detection is displayed.
- EDH: Transmission error detection flag immediately before the LV 5750. A value of 0 indicates normal; 1 indicates an error.
- EDA: Transmission error detection flag from a device before the LV 5750. A value of 0 indicates normal; 1 indicates an error.
- IDH: Error detection flag in the data transmission system inside the LV 5750. A value of 0 indicates normal; 1 indicates an error.

IDA: Data transmission error detection flag in the device before the LV 5750.
 A value of 0 indicates normal; 1 indicates an error.

UES: Indicates whether the previous equipment supports EDH packets.
 0: The entire SDI signal system supports EDH packets.
 1: An equipment that does not support EDH packets is connected.

RECEIVED CRC FF: Full field CRC reception error
 NORMAL: The full field CRC of the EDH packet and the full field CRC recalculated from the received data match (no reception error).
 ERROR: The full field CRC of the EDH packet and the full field CRC recalculated from the received data do not match (reception error).

RECEIVED CRC AP: Active picture CRC reception error
 NORMAL: The active picture CRC of the EDH packet and the active picture CRC recalculated from the received data match (no reception error).
 ERROR: The active picture CRC of the EDH packet and the active picture CRC recalculated from the received data do not match (reception error).

11.6 Error Detection Setting

Press **F.5** ERROR CONFIG from the status display menu to show the error configuration menu as shown in figure 11.14.

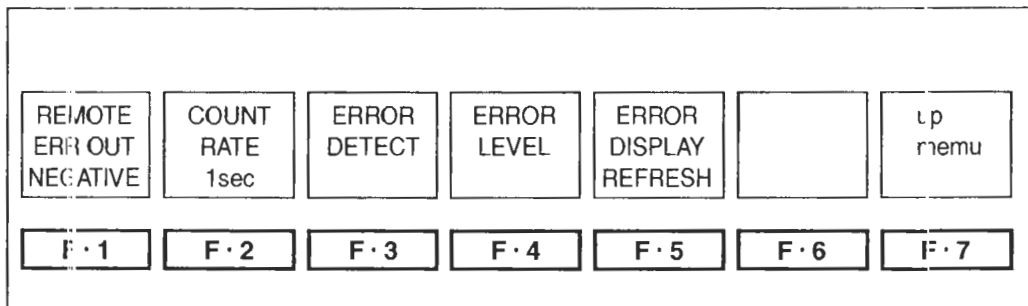

Figure 11.14 Error configuration menu

Function Key	Description
F.1 REMOTE ERR OUT	Sets the error signal output when the Remote Control Unit sold separately is installed
F.2 COUNT RATE	Sets the count rate of the error count.
F.3 ERROR DETECT	Sets whether to detect each error.
F.4 ERROR LEVEL	Sets the to error threshold level.
F.5 ERROR DISPLAY	Selects whether to refresh or hold the error display.

Table 11.6 Error configuration menu description

11.6.1 Error Alarm Setting

Press [F.1] REMOTE ERR OUT from the error setup menu to select the polarity of the error signal that is output from the optional Remote Control Unit that is sold separately.

[[STATUS] → [F.5] ERROR CONFIG → [F.1] REMOTE ERR OUT : OFF / POSITIVE / NEGATIVE]

Error alarm output pins are assigned to the REMOTE connector of the optional Remote Control Unit that is inserted in the external IF slot ④ on the rear panel. This output transmits a pulse when an error occurs in any of the items that have been turned ON in section 11.6.3, "Detection ON/OFF of Errors.

OFF: Errors are not output from the remote connector.

POSITIVE: A high level signal is output when an error occurs.

NEGATIVE: A low level signal is output when an error occurs.

For the location of the output pin, see the instruction manual of the option (Remote Control Unit) that is sold separately.

11.6.2 Error Count Rate Setting

[[STATUS] → [F.5] ERROR CONFIG → [F.2] COUNT RATE:V RATE / 1sec]

Press [F.2] COUNT RATE from the error configuration menu to select the count rate of the error count on the status display screen.

V RATE: Increments the error count per field (frame for progressive). Even if multiple errors occur within a field, the error count is incremented only by 1.

1sec: Increments the error count per second. Even if multiple errors occur within a second, the error count is incremented only by 1.

11.6.3 Detection ON/OFF of Errors

Press [F.3] ERROR DETECT from the error configuration menu to show the error detection setup menu. You can turn ON/OFF the error detection function of each error from this menu.

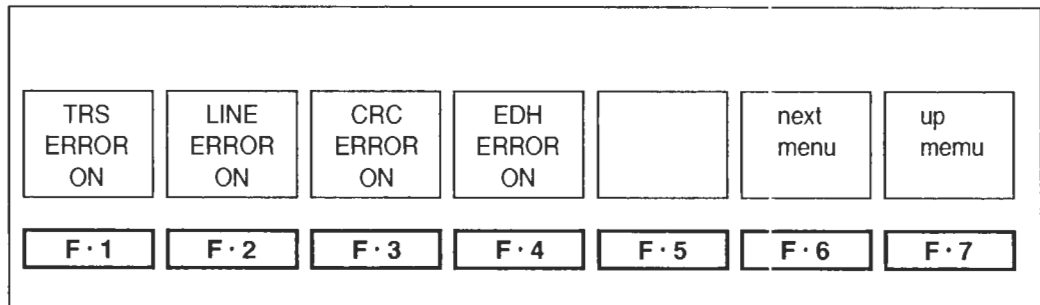

(a) Error detection setup menu page 1

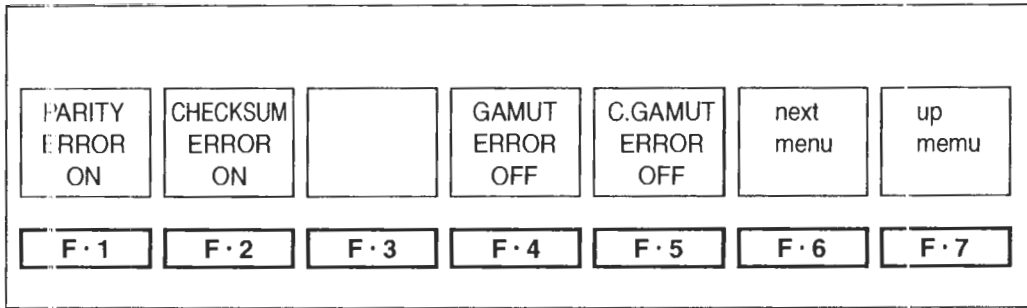

(b) Error detection setup menu page 2

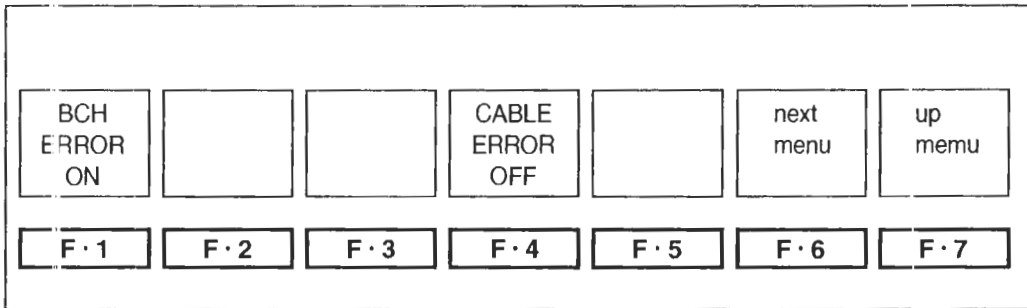

(c) Error detection setup menu page 3

Figure 11.15 Error detection setup menu

(1) TRS Error ON/OFF

[[STATUS] → [F.5] ERROR CONFIG → [F.3] ERROR DETECT → [F.1] TRS ERROR:ON / OFF]

To turn ON/OFF the TRS error detection function, press [F.1] TRS ERROR from the error detection setup menu to select ON or OFF.

(2) Line Number Error ON/OFF

[[STATUS] → [F.5] ERROR CONFIG → [F.3] ERROR DETECT → [F.2] LINE ERROR :ON / OFF]

To turn ON/OFF the line number error detection function, press [F.2] LINE ERROR from the error detection setup menu to select ON or OFF.

The detection function only works on HD-SDI signals.

(3) CRC Error ON/OFF

[[STATUS] → [F.5] ERROR CONFIG → [F.3] ERROR DETECT → [F.3] CRC ERROR:ON / OFF]

To turn ON/OFF the CRC error detection function when HD-SDI signals are input, press [F.3] CRC ERROR from the error detection setup menu to select ON or OFF.

(4) EDH Error ON/OFF

[**STATUS**] → [**F.5**] ERROR CONFIG → [**F.3**] ERROR DETECT → [**F.4**] EDH ERROR:ON / OFF]

To turn ON/OFF the EDH error detection function when SD-SDI signals are input, press [**F.4**] EDH ERROR from the error detection setup menu to select ON or OFF.

If the function is turned OFF, the result of EDH error detection is not displayed on the status display screen. However, the status of the EDH flag is displayed in the detailed status display of EDH.

(5) Parity Error ON/OFF

[**STATUS**] → [**F.5**] ERROR CONFIG → [**F.3**] ERROR DETECT → [**F.6**] next menu → [**F.1**] PARITY ERROR:ON / OFF]

To turn ON/OFF the parity error detection function, press [**F.6**] next menu from the error detection setup menu followed by [**F.1**] PARITY ERROR to select ON or OFF.

(6) Checksum Error ON/OFF

[**STATUS**] → [**F.5**] ERROR CONFIG → [**F.3**] ERROR DETECT → [**F.6**] next menu → [**F.2**] CHECKSUM ERROR : ON / OFF]

To turn ON/OFF the checksum error detection function, press [**F.6**] next menu from the error detection setup menu followed by [**F.2**] CHECKSUM ERROR to select ON or OFF.

(7) Gamut Error ON/OFF

[**STATUS**] → [**F.5**] ERROR CONFIG → [**F.3**] ERROR DETECT → [**F.6**] next menu → [**F.4**] GAMUT ERROR:ON / OFF]

To turn ON/OFF the gamut error detection function, press [**F.6**] next menu from the error detection setup menu followed by [**F.4**] GAMUT ERROR to select ON or OFF.

(8) Composite Gamut Error ON/OFF

[**STATUS**] → [**F.5**] ERROR CONFIG → [**F.3**] ERROR DETECT → [**F.6**] next menu → [**F.5**] C.GAMUT ERROR:ON / OFF]

To turn ON/OFF the composite gamut error detection function, press [**F.6**] next menu from the error detection setup menu followed by [**F.5**] C.GAMUT to select ON or OFF.

(9) BCH Error ON/OFF

[**STATUS**] → [**F.5**] ERROR CONFIG → [**F.3**] ERROR DETECT → [**F.6**] next menu → [**F.6**] next menu → [**F.1**] BCH ERROR:ON / OFF]

To turn ON/OFF the BCH error detection function, press [**F.6**] next menu twice from the error detection setup menu followed by [**F.1**] BCH ERROR to select ON or OFF.

The detection function only works on HD-SDI signals.

(10) Equivalent Cable Length Meter Alarm ON/OFF

[**[STATUS]** → **[F.5]** ERROR CONFIG → **[F.3]** ERROR DETECT → **[F.6]** next menu → **[F.6]** next menu → **[F.4]** CABLE ERROR :ON / OFF]

To turn ON/OFF the function for sounding an alarm (cable length meter indicated using red characters) when the cable length measured by the equivalent cable length meter function exceeds a specified value, press **[F.6]** next menu twice from the error detection setup menu followed by **[F.4]** CABLE ERROR to select ON or OFF.

11.7 Detection Value Setting of Errors

Select **[F.4]** ERROR LEVEL from the error configuration menu to show the error level selection menu for setting the threshold levels for error detection.

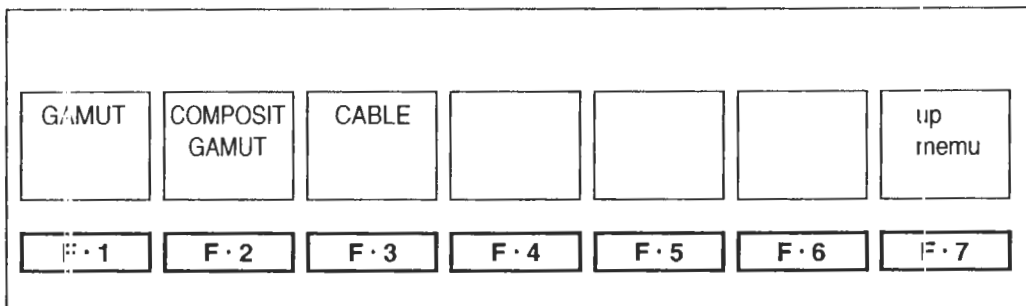

Figure 11.16 Error level item selection menu

Function Key	Description
F.1 GAMUT	Sets the gamut error threshold level.
F.2 COMPOSIT GAMUT	Sets the composite gamut error threshold level.
F.3 CABLE	Set the cable length meter error threshold level.

Table 11.7 Description of the error level item selection menu

11.7.1 Gamut Error Threshold Level

Press **[F.1]** GAMUT from the error level item selection menu to show the gamut error threshold level setup menu. You can set the gamut error threshold level from this menu.

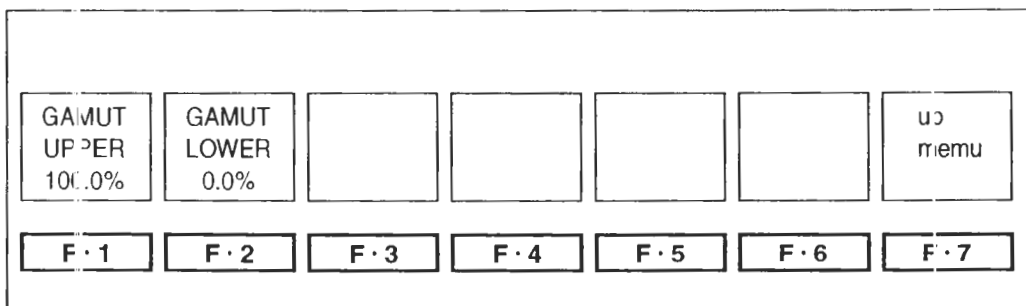

Figure 11.17 Gamut error threshold level setup menu

[**STATUS**] → [**F.5**] ERROR CONFIG → [**F.4**] ERROR LEVEL → [**F.1**] GAMUT → [**F.1**] GAMUT UPPER:90.8% ~ 109.4%]

[**STATUS**] → [**F.5**] ERROR CONFIG → [**F.4**] ERROR LEVEL → [**F.1**] GAMUT → [**F.2**] GAMUT LOWER:-7.2% ~ 6.1%]

From the gamut error threshold level setup menu, press [**F.1**] GAMUT UPPER or [**F.2**] GAMUT LOWER and set the threshold levels to define signal levels used to determine gamut errors.

If a signal level greater than the UPPER value is detected, a gamut error occurs.
If a signal level smaller than the LOWER value is detected, a gamut error occurs.

11.7.2 Composite Gamut Error Threshold Level

Press [**F.2**] COMPOSIT GAMUT from the error level item selection menu to show the composite gamut error threshold level setup menu. You can set the composite gamut error threshold level from this menu.

C. GAMUT UPPER 100.0%	C. GAMUT LOWER 0.0%					up menu
[F.1]	[F.2]	[F.3]	[F.4]	[F.5]	[F.6]	[F.7]

Figure 11.18 Composite gamut error threshold level setup menu

[**STATUS**] → [**F.5**] ERROR CONFIG → [**F.4**] ERROR LEVEL → [**F.2**] COMPOSIT GAMUT → [**F.1**] C. GAMUT UPPER:90.0% ~ 135.0%]

[**STATUS**] → [**F.5**] ERROR CONFIG → [**F.4**] ERROR LEVEL → [**F.2**] COMPOSIT GAMUT → [**F.2**] C. GAMUT LOWER:-40.0% ~ -20.0%]

From the composite gamut error threshold level setup menu, press [**F.1**] COMPOSIT UPPER or [**F.2**] COMPOSIT LOWER and set the threshold levels to define signal levels used to determine composite gamut errors.

If a signal level greater the specified UPPER value is detected when the SDI signal is converted to composite signal, a composite gamut error occurs.

If a signal level less than the specified LOWER value is detected when the SDI signal is converted to composite signal, a composite gamut error occurs.

11.7.3 Detection Value of Equivalent Cable Length Meter Error

Press **[F.3]** CABLE from the error level item selection menu to show the cable length meter error threshold level setup menu. You can set the cable length meter error threshold level from this menu.

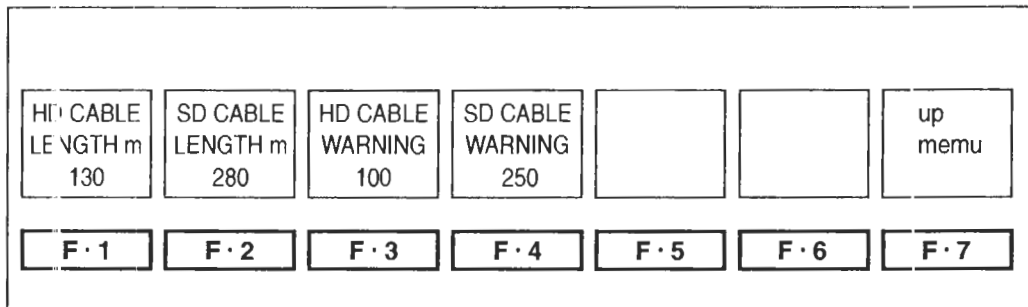

Figure 11.19 Cable length meter error threshold level setup menu

(1) Cable Length Meter Error of HD-SDI Signals

[**[STATUS]**] → **[F.5]** ERROR CONFIG → **[F.4]** ERROR LEVEL → **[F.3]** CABLE
→ **[F.1]** HD CABLE LENGTH: 5m ~ 200m]

From the cable length meter error threshold setup menu, press **[F.1]** HD CABLE LENGTH and set the cable length (signal attenuation) used to determine equivalent cable length meter errors in the HD-SDI input signal.

If the cable length meter indication is greater than the specified value, an equivalent cable length meter error occurs.

If an error occurs, the equivalent cable length meter indication for CABLE LENGTH in the status display menu is shown in red.

(2) Cable Length Meter Error of SD-SDI Signals

[**[STATUS]**] → **[F.5]** ERROR CONFIG → **[F.4]** ERROR LEVEL → **[F.3]** CABLE
→ **[F.2]** SD CABLE LENGTH: 50m ~ 300m]

From the cable length meter error threshold setup menu, press **[F.2]** SD CABLE LENGTH and set the cable length (signal attenuation) used to determine equivalent cable length meter errors in the SD-SDI input signal.

If the cable length meter indication is greater than the specified value, an equivalent cable length meter error occurs.

If an error occurs, the equivalent cable length meter indication for CABLE LENGTH in the status display menu is shown in red.

(3) Cable Length Meter Alarm of HD-SDI Signals

[**[STATUS]**] → **[F.5]** ERROR CONFIG → **[F.4]** ERROR LEVEL → **[F.3]** CABLE
→ **[F.3]** HD CABLE WARNING: 5m ~ 200m]

From the cable length meter error threshold setup menu, press **[F.3]** HD CABLE WARNING and set the cable length (signal attenuation) used to determine equivalent cable length meter alarms of the HD-SDI input signal.

If the cable length meter indication is greater than the specified value, an equivalent cable length meter alarm is indicated.

If an alarm occurs, the equivalent cable length meter indication for CABLE LENGTH in the status display menu is shown in yellow.

(4) Cable Length Meter Alarm of SD-SDI Signals

[**[STATUS]** → **[F.5]** ERROR CONFIG → **[F.4]** ERROR LEVEL → **[F.3]** CABLE
→ **[F.4]** SD CABLE WARNING: 50m ~ 300m]

From the cable length meter error threshold setup menu, press **[F.4]** SD CABLE WARNING and set the cable length (signal attenuation) used to determine equivalent cable length meter alarms of the SD-SDI input signal.

If the cable length meter indication is greater than the specified value, an equivalent cable length meter alarm is indicated.

If an alarm occurs, the equivalent cable length meter indication for CABLE LENGTH in the status display menu is shown in yellow.

11.8 Error Display Operation

[**[STATUS]** → **[F.5]** ERROR CONFIG → **[F.5]** ERROR DISPLAY: REFRESH / HOLD]

There are two methods of displaying errors on the status display. The error indication can be set to disappear after approximately 1 second or remain displayed until the error is reset.

From the status display menu, press **[F.5]** ERROR DISPLAY. Select REFRESH to display error indications for approximately 1 second. Select HOLD to hold error indications until errors are reset.

11.9 Cable Selection of the Cable Length Meter

You can select the type of cable to which the SDI signal level is converted on the cable length meter on the status display.

From the status display menu, press **[F.6]** CABLE LENGTH to show the cable selection menu of the equivalent cable length meter.

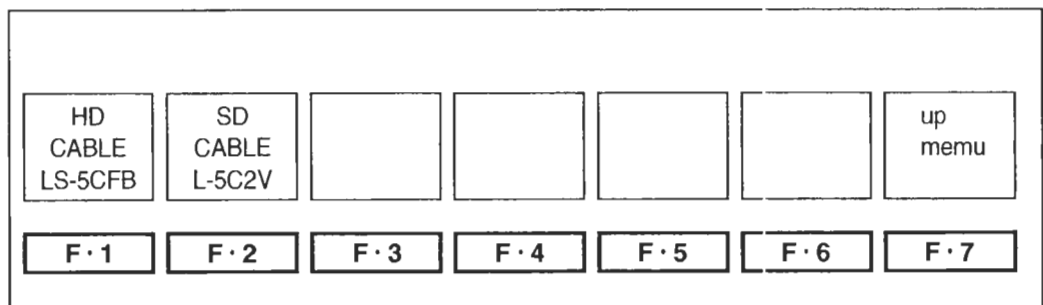

Figure 11.20 Cable selection menu of the cable length meter

11.9.1 HD-SDI Cable Selection

[**[STATUS]** → **[F.6]** CABLE LENGTH → **[F.1]** HD CABLE: LS-5CFB / 1694A / L-7CHD]

To select the type of cable for the conversion on the HD-SDI cable length meter, press **[F.1]** HD CABLE from the cable selection menu of the cable length meter. Select LS-5CFB, 1694A or L-7CHD.

11.9.2 SD-SDI Cable Selection

[**STATUS**] → [**F.6**] CABLE LENGTH → [**F.2**] SD CABLE: L-5C2V / 8281 / 1505A]

To select the type of cable for the conversion on the SD-SDI cable length meter, press [**F.2**] SD CABLE from the cable selection menu of the cable length meter. Select L-5C2V, 8281, or 1505A.

11.10 Error Reset

[**STATUS**] → [**F.7**] ERROR RESET]

To reset the error indication on the status display screen and the error log, press [**F.7**] RESET from the status display menu. The error indication is reset with a beep sound.

12. CAPTURE FUNCTION

The LV 5750 can copy the screen display to the internal memory or a compact flash card. If the screen display is saved to the internal memory, the data is lost when the screen display is changed or when the power is turned OFF. If the screen display is saved to a compact flash card, the data is saved even when the power is turned OFF. The data can be read on a PC as bitmap images.

Press the CAPTURE key ⑤ to capture the screen image to the internal memory of the LV 5750. The capture menu appears.

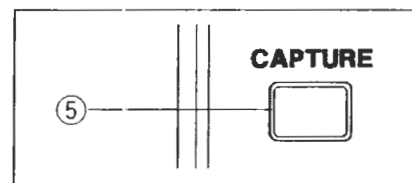

Figure 12.1 CAPTURE key ⑤

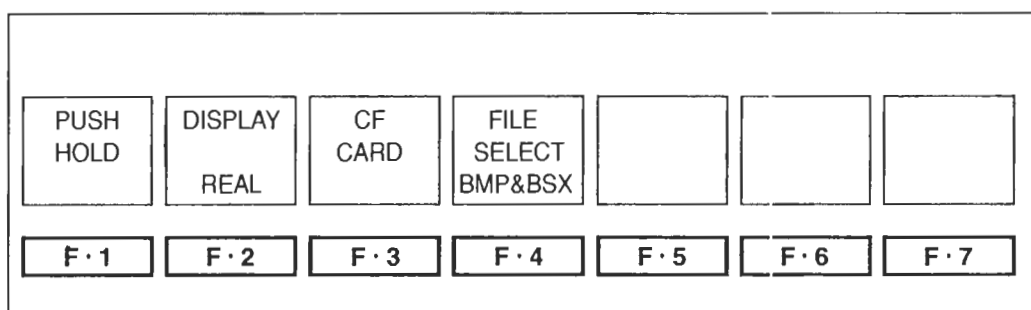

Figure 12.2 Capture menu

Function Key	Description
F·1 PUSH HOLD	Captures the screen to the internal memory.
F·2 DISPLAY	Selects to display the captured image.
F·3 CF CARD	Performs compact flash card operation.
F·4 FILE SELECT	Selects the file type to be saved, BMP or BSX.

Table 12.1 Capture Menu Description

Carry out the following procedure to use the capture function.

- (1) Show the display you wish to capture.
- (2) Press the CAPTURE key ⑤ to capture the displayed contents in the LV 5750.
- (3) Press **[F·2]** DISPLAY to select whether to show the captured image or the current content. You can also select overlay display.
To store to a compact flash card, continue with the following procedure.
- (4) Press **[F·3]** CF CARD to show the compact flash card storage menu.
- (5) Press **[F·1]** NAME INPUT to specify the name of the captured image file.
After you have specified the name, press **[F·7]** up menu.
- (6) Press **[F·2]** STORE CARD to store the data to the compact flash card.

12.1 Screen capture

To use the capture function, show the display you wish to capture.

Then, press the CAPTURE key ⑤ to capture the displayed contents in the LV 5750.

The image data captured in the internal memory is cleared when you switch the screen display such as when you switch from the waveform display to the vectorscope display. The contents in the internal memory are also cleared when the power is turned OFF.

Simply capturing the display does not show the captured image on the screen. Carry out the procedure described in section 12.2, "Display Selection" to show the captured image.

Press **F.1** PUSH HOLD from the capture menu to capture the displayed contents again.

12.2 Display Selection

You can select how the captured data in the internal memory is displayed.

You can select the display method from 1) display the newest information, 2) display the captured image, and 3) display the newest information and captured image overlaid.

When using overlay display, the brightness of the newest information is cut to half, and the brightness of cyan is cut to half on the captured image.

DISPLAY selection

REAL: Displays the newest information.

HOLD: Displays the captured image.

BOTH: Displays both newest information and captured image overlaid.

If you select HOLD, the video signal waveform display, vectorscope display, audio waveform display, data dump, and picture display show the captured image. However, the scale, readout, and audio level meter continue showing the newest information.

The bitmap data stored to the compact flash card is the information existing at the time the capture operation is carried out.

12.3 Storage to the Compact Flash Card

The image data captured in the internal memory of the LV 5750 is cleared when you switch the display or when you turn OFF the power.

To keep the captured image from being cleared, the data must be stored to a compact flash card. By storing the data in a compact flash card, the image can be displayed on another device such as your PC, or it can be rewritten to the internal memory of the LV 5750 at a later time.

The captured image can be transmitted directly to a PC via the Ethernet network.

* Use FAT16 for the file system on the compact flash card.

Writing is not possible on other file systems such as FAT32 and NTFS.

① Showing the compact flash card storage menu

[CAPTURE] → [F.3] CF CARD]

From the error log display menu, press [F.3] CF CARD to show the compact flash card storage menu.

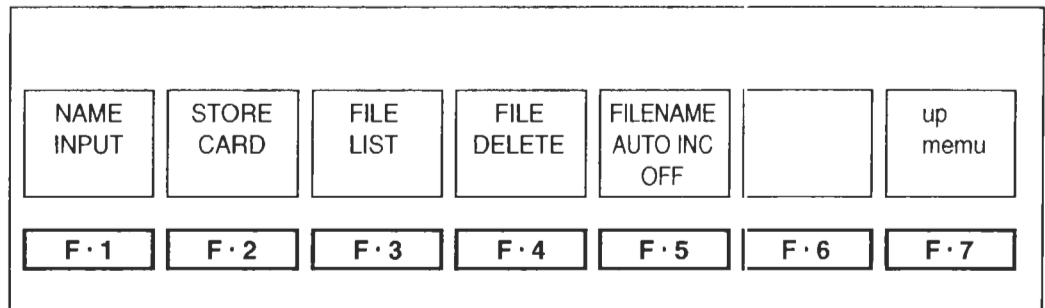

Figure 12.3 Compact flash card storage menu

② Specifying the file name

[CAPTURE] → [F.3] CF CARD → [F.1] NAME INPUT]

From the compact flash card storage menu, press [F.1] NAME INPUT to show the file name entry screen.

Enter the file name using the function key ([F.1] to [F.7]) ② and the function dial ([F.D]) ⑱. After you finish entering the file name, press [F.7] up menu. If a space is included in the file name, it is converted to an underscore.

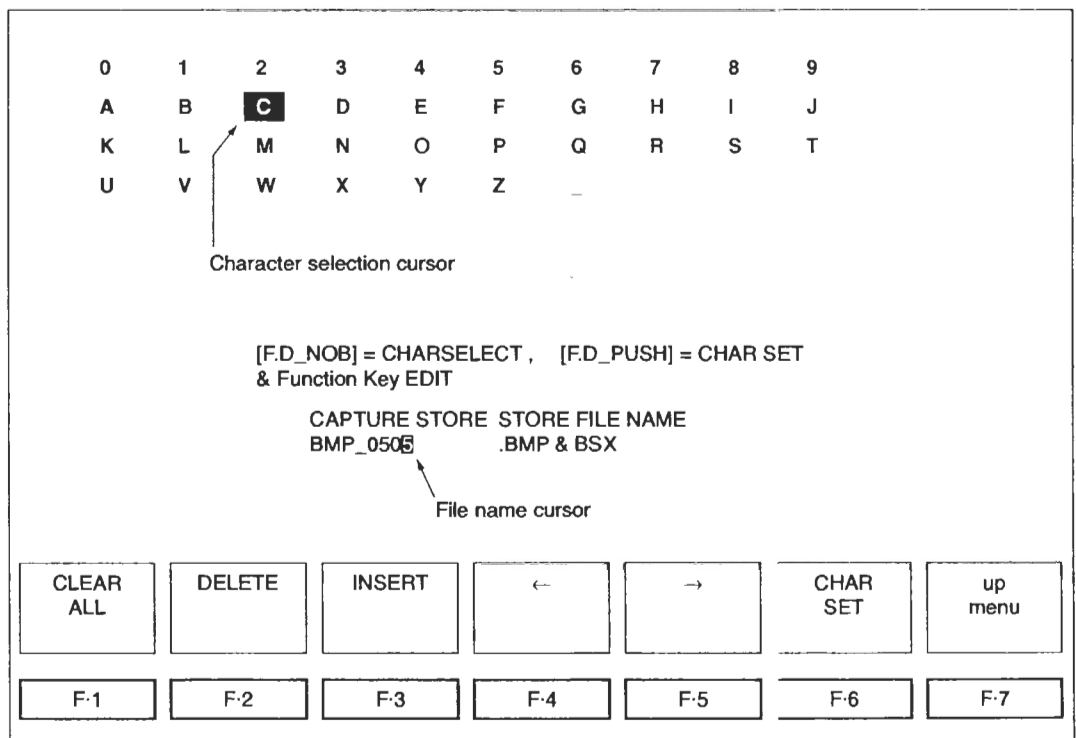

Figure 12.4 File name entry screen

Function Key	Description
F 1 CLEAR ALL	Clears the file name
F 2 DELETE	Clears the character at the file name cursor
F 3 INSERT	Enter a single space at the file name cursor
F 4 ←	Moves the file name cursor to the left by a character
F 5 →	Moves the file name cursor to the right by a character
F 6 CHAR SET	Applies the character at the character selection cursor to the file name.
F 7 up menu	Confirms the file name

Table 12.2 File name entry menu

③ Storing the image data to the card

[[CAPTURE] → [F.3] CF CARD → [F.2] STORE CARD]

Check that a compact flash card is inserted in the dedicated interface card for the LV 5750. (The interface card is inserted in the external IF slot ②④ on the rear panel.) Then press [F.2] STORE CARD.

The image data is saved to the compact flash card as a capture data file.

If a compact flash card is not inserted in the dedicated interface card, a message "No Card In Slot" is displayed.

After the writing of the capture data is complete, a file list of the compact card is displayed.

The file list only displays the capture data bitmap files.

* **BSX files**

When a captured image data is written to the compact flash card, a BMP (bitmap) file and a BSX file are created. The bitmap file is used when displaying the captured image data on another device such as your PC. The BSX file is used to recall the image data on the LV 5750 and contains setup items of the LV 5750 that were used at the time the image was captured in addition to the waveform data.

Bitmap data cannot be used to recall the captured image on the LV 5750. To select whether to save the BSX file or BMP file, carry out the procedure given in section 12.8, "Storage File Selection."

12.4 Recalling from the Compact Flash Card

[**CAPTURE**] → [**F.3**] CF CARD → [**F.6**] RECALL CARD]

BSX files are needed to recall the image data stored to the compact flash card. Insert the compact flash card containing the BSX file into the CF CARD slot on the rear panel. From the capture menu, press [**F.3**] FILE LIST to show a list of captured image files on the compact flash card.

Select the file to be recalled from the list using the function dial [**F.D**] ①9.

Next, press [**F.6**] RECALL CARD to recall the captured image into the LV 5750.

The LV 5750 is configured according to the settings included in the BSX file.

However, the audio level meter display and the readout values at the time errors occurred cannot be recalled from the compact flash card, because they are not stored in the BSX file.

12.5 File List of the Compact Flash Card

[**CAPTURE**] → [**F.3**] CF CARD → [**F.3**] FILE LIST]

To display the file list of the compact flash card, press [**F.3**] FILE LIST from the compact flash card storage menu. The file list only displays the captured BSX files.

If a compact flash card is not inserted in the dedicated interface card, a message "No Card In Slot" is displayed.

12.6 Deletion of Capture Files

[**CAPTURE**] → [**F.3**] CF CARD → [**F.4**] FILE DELETE]

To delete a capture file, press [**F.4**] FILE DELETE from the compact flash card storage menu. Then, press [**F.1**] DELETE YES to delete the selected capture file. Press [**F.3**] DELETE NO to not delete the file. The screen returns to the compact flash card storage menu.

12.7 Auto Increment of File Names

[**STATUS**] → [**F.1**] LOG → [**F.6**] CF CARD → [**F.5**] FILENAME AUTO INC : ON / OFF]

A number can be added automatically to the file name of data stored to the compact flash memory card.

12.8 Storage File Selection

[**CAPTURE**] → [**F.4**] FILE SELECT: BMP&BSX / BMP / BSX]

From the capture menu, press [**F.4**] FILE SELECT. You can select the type of file for storing the captured image data to the compact flash card.

BMP&BSX: Stores the bitmap file and BSX file to the compact flash card. One capture image requires approximately 4.7 MB of free space. The bitmap file can be used to display the image on a device such as a PC, and the BSX file can be used to display the image on the LV 5750.

- 3MP: Stores only the bitmap file to the compact flash card.
One capture image requires approximately 2.4 MB of free space.
The bitmap file cannot be used to display the image on the LV 5750.
- 3SX: Stores only the BSX file to the compact flash card.
One capture image requires approximately 2.4 MB of free space.
The BSX file is used to display the image on the LV 5750.

13. Preset Function

You can register up to 30 sets of settings excluding the power ON/OFF setting and Ethernet settings on the LV 5750 and recall them later.

In addition, settings stored to the memory can be recalled via the REMOTE connector by installing the optional Remote Control Unit sold separately into the external IF slot ④ on the rear panel.

13.1 Recalling of Settings

Press the RECALL key ② to display the recall menu. You can recall stored panel settings from this menu. Recall numbers are assigned to the (F.1 to F.6) function keys ②.

If there are more than six sets of stored settings, press F.7 more to display them.

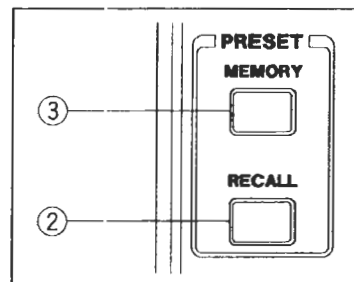

Figure 13.1 RECALL key ②
MEMORY key ③

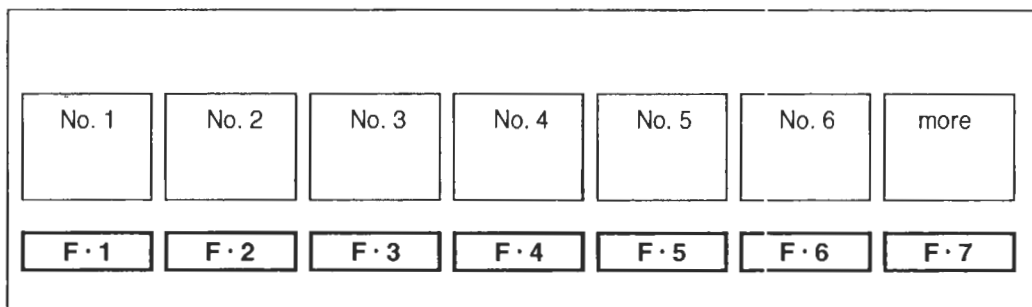
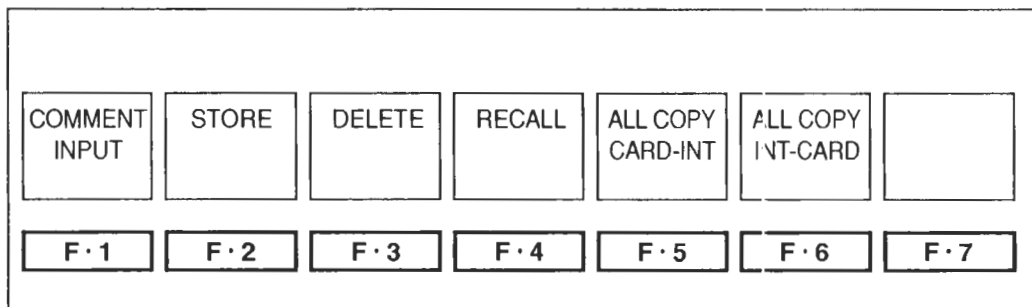

Figure 13.2 Recall menu

13.2 Registration of Settings

Press the MEMORY key ③ to display the memory menu. The settings existing at that point can be saved using this menu. You can attach a comment for each setup item.



Memory menu page

Figure 13.3 Memory menu

Function Key	Description
F·1 COMMENT INPUT	Enters comments
F·2 STORE	Stores the settings
F·3 DELETE	Clears the memory
F·4 RECALL	Recalls presets
F·5 ALL COPY CARD-INT	Copies all the presets stored on the compact flash card to the internal memory
F·6 ALL COPY INT-CARD	Copies all the presets stored in the internal memory to the compact flash card

Table 13.1 Memory Menu Description

13.2.1 Comment Entry

[**MEMORY**] → [**F·1**] COMMENT INPUT]

You can enter a comment for each preset number.

To enter a comment, press [**F·1**] COMMENT from the memory menu to display the comment entry screen.

Enter the comment using the function key ([**F·1**] to [**F·7**]) ② and the function dial ([**F·D**]) ⑱. When you are done, press [**F·7**] up menu to return.

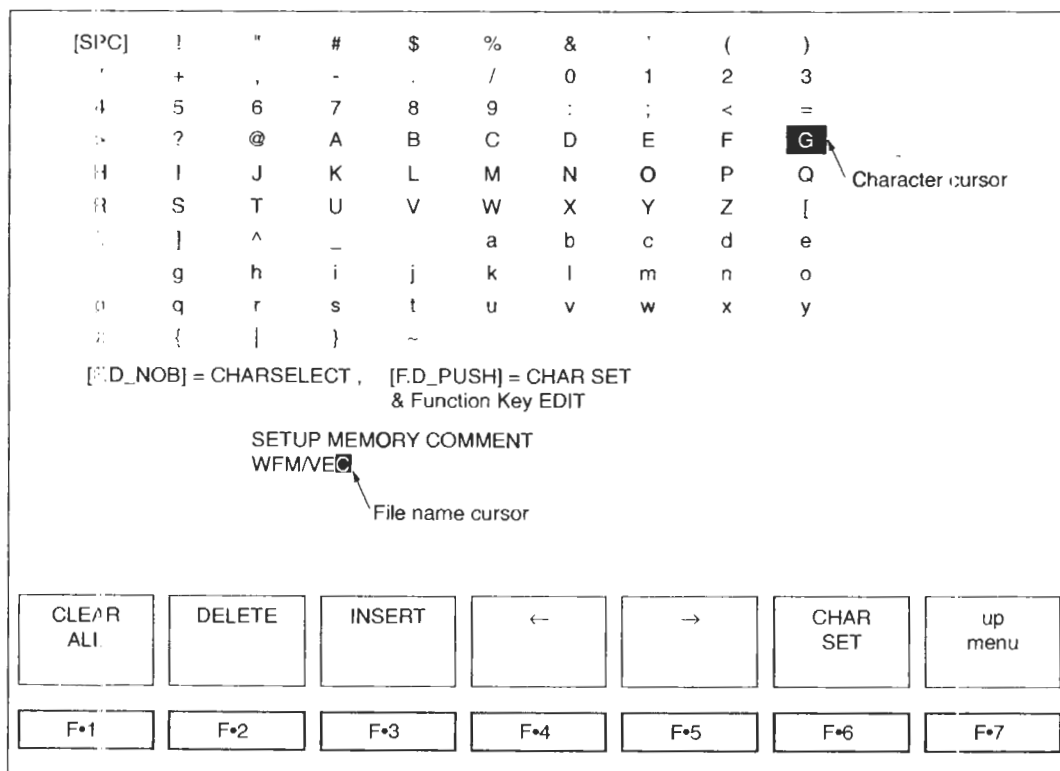

Figure 13.4 File name entry screen

Function Key	Description
F-1 CLEAR ALL	Clears the file name
F-2 DELETE	Clears the character at the file name cursor
F-3 INSERT	Enter a single space at the file name cursor
F-4 ←	Moves the file name cursor to the left by a character
F-5 →	Moves the file name cursor to the right by a character
F-6 CHAR SET	Applies the character at the character selection cursor to the file name.
F-7 up menu	Confirms the file name
F-D	Moves the character cursor

Table 13.2 File name entry menu

13.2.2 Storing of the Settings

After entering the comment, turn the function dial (F·D) ⑨ on the memory menu and select the desired preset number for registering the settings. Then, press F-3 STORE to store the settings.

13.2.3 Deleting of the Settings

To delete settings that have been registered as a preset, turn the function dial (F·D) ⑨ on the memory menu to select the preset number you wish to delete. Then, press F-4 DELETE. F-1 DELETE YES and F-3 DELETE NO appear for you to confirm the operation. Press F-1 to delete or F-3 to cancel.

13.2.4 Editing of Presets

To edit or recall the preset contents, press F-5 RECALL from the memory menu. The screen display keeps showing the list of presets, but when you exit from the memory menu, the recalled settings are activated.

The recall function here is mainly used to move the preset number or copy the contents to another preset number.

After recalling a preset, select a preset number and press F-3 STORE to copy the contents of the recalled preset.

13.3 Copying of All Presets

If you wish to make the presets on multiple LV 5750 monitors the same, you can use the compact flash card to do so.

* Use FAT16 for the file system on the compact flash card.

Writing is not possible on other file systems such as FAT32 and NTFS.

13.3.1 Copying from the CF Card to the Internal Memory

[MEMORY] → [F-5] ALL COPY CARD-INT]

From the memory menu page 2, press F-5 ALL COPY CARD-INT to copy all the presets on the compact flash card to the internal preset memories.

13.3.2 Copying from the Internal Memory to the CF Card

[**M**EMORY] → [**F-6**] ALL COPY INT-CARD]

From the memory menu page 2, press [**F-6**] ALL COPY INT-CARD to copy all the presets in the internal memories to the compact flash card.



LEADER ELECTRONICS CORP.

2-6-33 Tsunashima-Higashi, Kohoku-ku, Yokohama 223-8505, Japan
PHONE: 81-45-541-2123 FAX: 81-45-541-2823

LEADER INSTRUMENTS CORP.

6484 Commerce Drive, Cypress, California 90630 U.S.A.
PHONE: 1-714-527-9300 FAX: 1-714-527-7490

LEADER INSTRUMENTS (H.K.) LTD.

Room 303-304 New East Ocean Centre, 9 Science Museum Road,
Tsimshatsui East, Kowloon, HONG KONG
PHONE: 852-2721-2503 FAX: 852-2723-7573

LEADER

MULTI SDI MONITOR

ADDENDUM INSTRUCTION MANUAL
For Software Version 2.1 or Higher

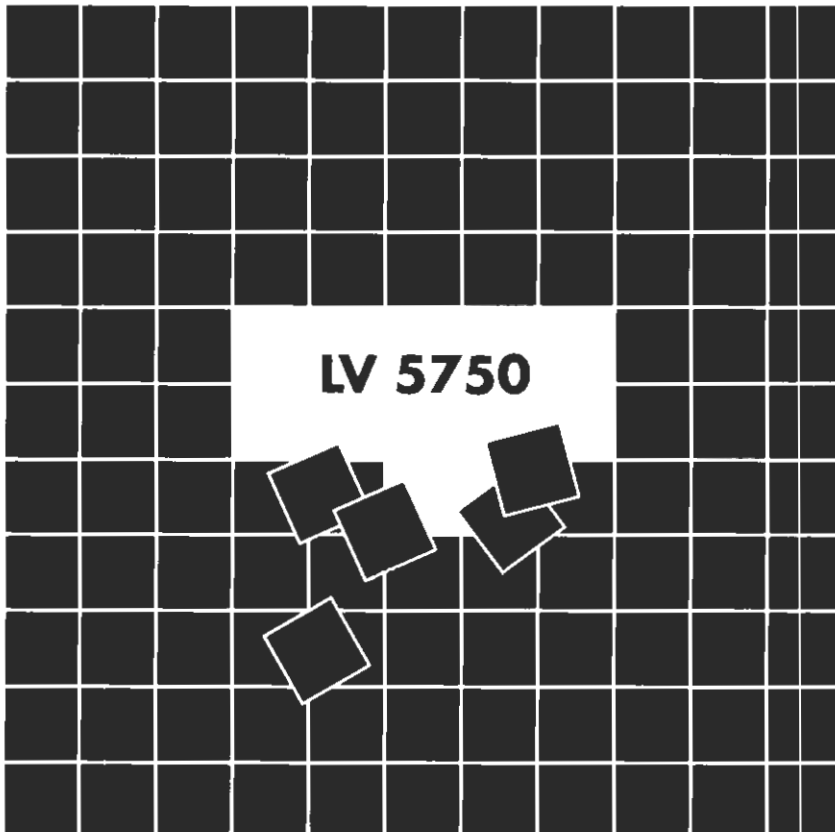

LEADER ELECTRONICS CORP.

TABLE OF CONTENTS

1. SPECIFICATIONS	1-1
1.1 Description	1-1
1.2 New Functions	1-1
2. NOTE	2-1
3. MENU STRUCTURE	3-1
4. SYSTEM CONFIGURATION	4-1
4.1 Additional Video Signal Formats	4-1
4.1.1 Video Signal Formats That Have Been Added	4-1
4.1.2 Video Signal Format Setting	4-1
4.2 Time Code	4-2
4.2.1 Time Code Display	4-2
4.2.2 LTC/VITC Selection	4-2
4.3 Remaining Battery Power Display	4-3
4.4 SNMP Support	4-3
5. BAR DISPLAY	5-1
5.1 Limit Setting	5-1
5.2 Gamut Display Frequency Characteristics	5-2
5.3 Miscellaneous	5-2
5.4 Details of Bar Display	5-2
6. STATUS DISPLAY	6-1
6.1 Supplementary Information Concerning the Status Display	6-1
6.2 Audio CRC Detection Function	6-2
6.2.1 Status Display of the Audio CRC	6-2
6.2.2 Event Log	6-2
6.2.3 Turning the Error Detection ON/OFF	6-2
6.3 V-ANC Monitor Function	6-3
6.3.1 ANC_PACKET Summary Display	6-3
6.3.2 Format ID Display	6-6
6.3.3 Closed Caption Data Display	6-7
6.3.4 Inter-Stationary Control Signal	6-10
6.4 Displaying Ancillary Data Markers Using Data Dump	6-13
7. SNMP COMMUNICATION	7-1
7.1 Description	7-1
7.2 SNMP Version Supported	7-1
7.3 Setup	7-1
7.3.1 Configuring the SNMP Manager	7-1

7.3.2	Setting the LV 5750	7-2
7.4	MIB (Management Information Base)	7-3
7.4.1	Standard MIB	7-3
7.4.1.1	Standard MIB Functions	7-3
7.4.2	Enterprise MIB	7-9
7.4.2.1	Retrieving the Enterprise MIB File	7-9
7.4.2.2	Enterprise MIB Structure	7-9
7.4.2.3	Enterprise MIBs	7-10
7.5	Enterprise Trap	7-25
7.5.1	Trap Community Name	7-25
7.5.2	Setting the IP Address of the SNMP Manager	7-25
7.5.3	Specific Traps	7-25
7.5.4	Description of the Variable Binding List	7-26

1. SPECIFICATIONS

1.1 Description

This addendum instruction manual describes specifications and functions that are added when the LV 5750 firmware is upgraded from version 1.x to 2.1.

When viewing this manual, be sure to also refer to the LV 5750 Instruction Manual.

1.2 New Functions

- Additional Video Signal Formats

The following video signal formats have been added: 720p/50, *1720p/30, *1720p/29.97, *1720p/25, *1720p/24, and *1720p/23.98.

- Audio CRC Error Detection

CRC errors of the channel status data that is multiplexed in the embedded audio can be detected.

- V-ANC Monitor Function

List Display

The presence/absence of ancillary data including V-ANC can be listed.

Format ID Display

Displays the current video mode as defined by ARIB STD B-39 or the PAYLOAD ID packet as defined by SMPTE 352M.

V-ANC Data Display of the ARIB Standard

Displays the inter-stationary control data as defined by ARIB STD-B39.

Displays the closed caption data as defined by ARIB STD-B37.

Standard Supported

Signal Name	Standard Supported	DID	SCID
Format ID	SMPTE 352M	241h	101h
V-ANC ARIB Standard			
Inter-stationary control data	ARIB STD-B39	25Fh	1FEh
Data broadcast trigger signal	ARIB STD-B35	25Fh	1FDh
Digital closed caption	ARIB STD-B37	25Fh	1DFh (HD closed caption) 2DEh (SD closed caption) 2DDh (Analog)
User data 1	ARIB TR-B23	25Fh	2FCh
User data 2	ARIB TR-B23	25Fh	1FBh

- Remaining Battery Power Display
Displays the remaining power in the IDX or Anton/Bauer² battery.
 - SNMP Support
SNMP (Simple Network Management Protocol) can be used to control the LV 5750 and notify SDI signal errors.
 - Time Code Display
Displays the time code (LTC or VITC) as defined by SMPTE RP-188.
 - Gamut Bar Display
Displays a peak level meter for Y, G, B, R, and pseudo-composite signals.
 - Data Dump ADF/DID/DBN/SDID Marker Display
 - Performance Improvements
Support for large capacity compact flash cards and reduction in the time needed to write data
Magnification of the V scale on the composite waveform display
Enhancement to the TRS error detection function (for 525i/59.94)
- *1 Formats whose evaluation verification has not been completed as of March 2005.
- *2 Installation of the Anton/Bauer battery mount is a special order option.

2. NOTE

The hexagonal screws for removing the case are designed so that the screws cannot be inserted more than 5 mm from the inner chassis. If you are using the LV 5750 with the case removed, do not insert the hexagonal screws back into the screw holes. In addition, do not use these screw holes for purposes other than those specified by Leader. Inserting a screw longer than 5 mm can damage the LV 5750.

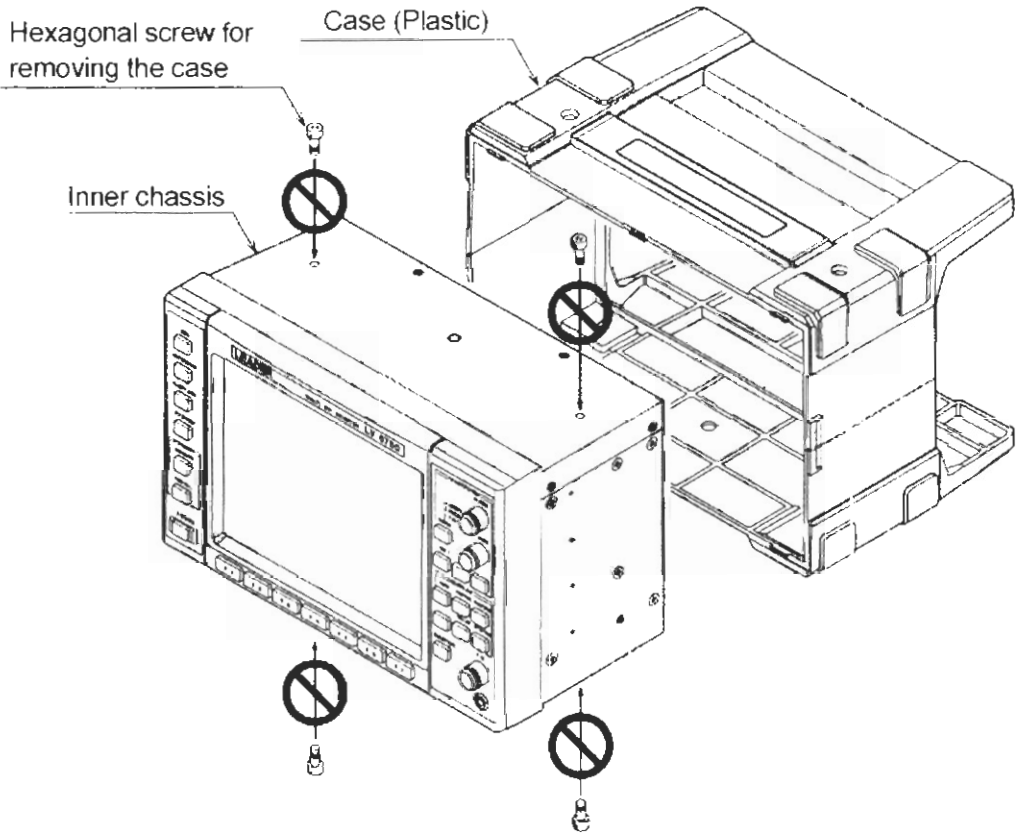
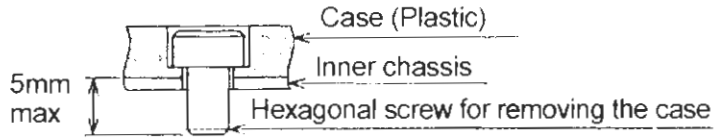

3. MENU STRUCTURE

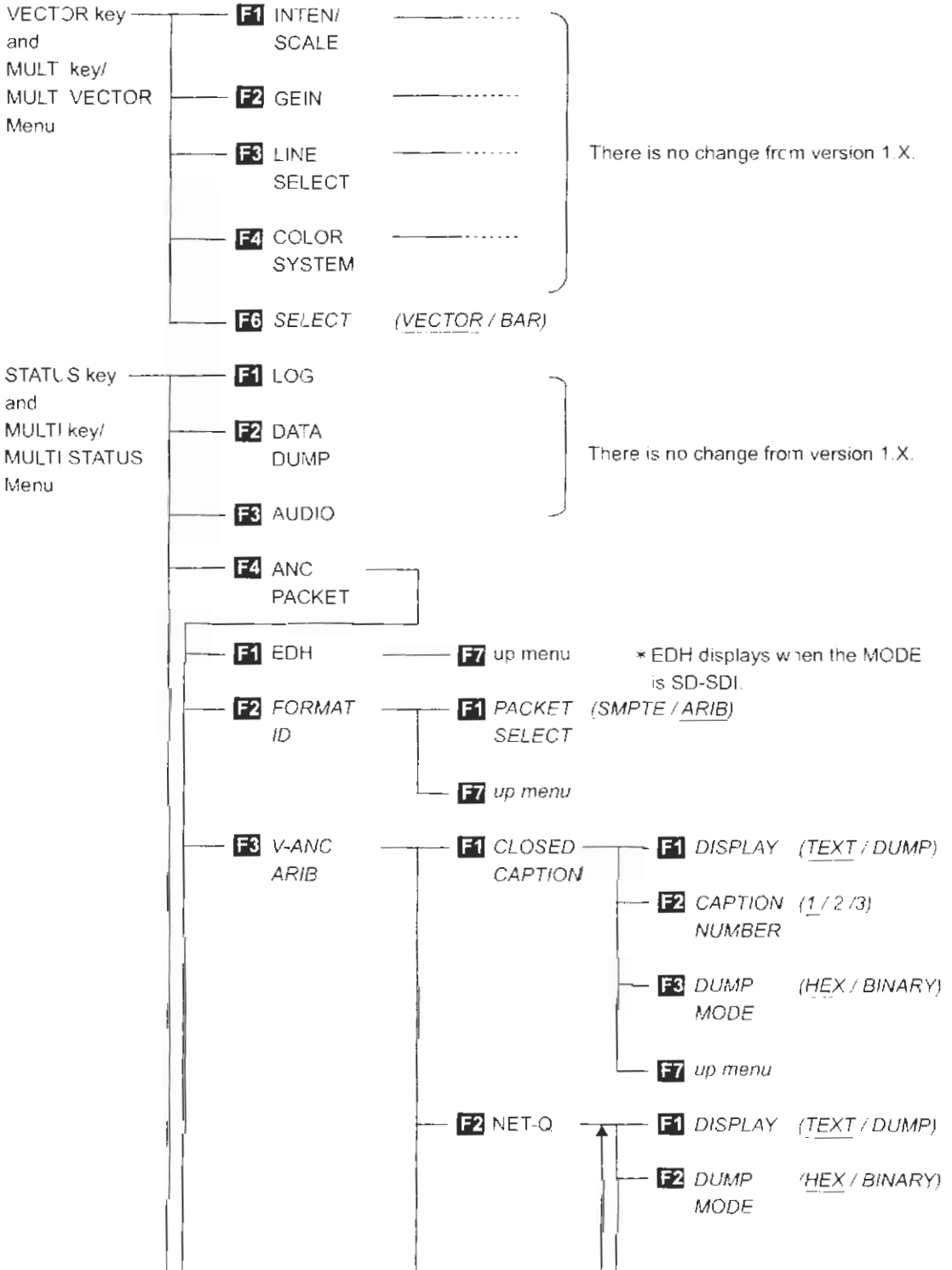

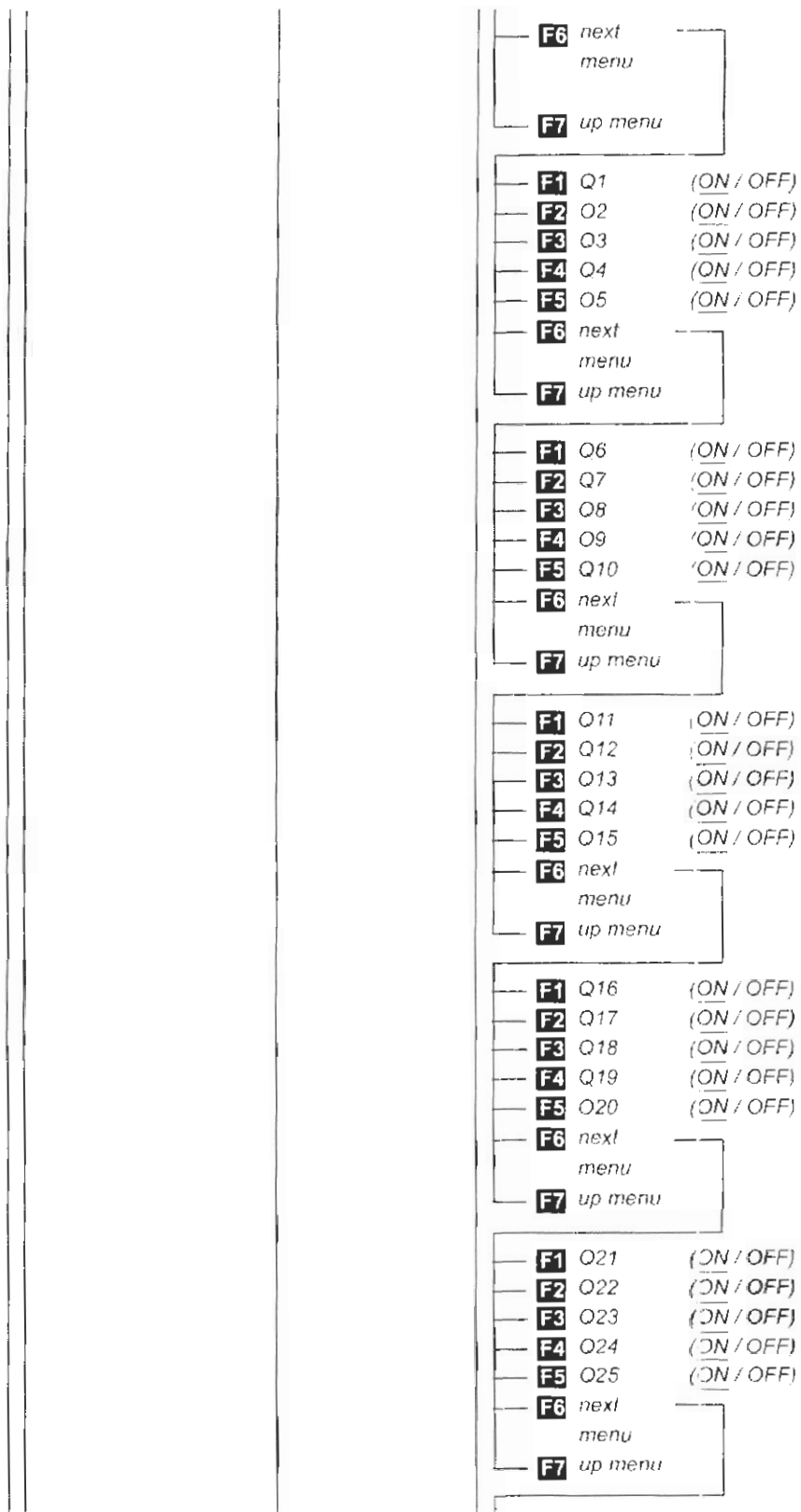

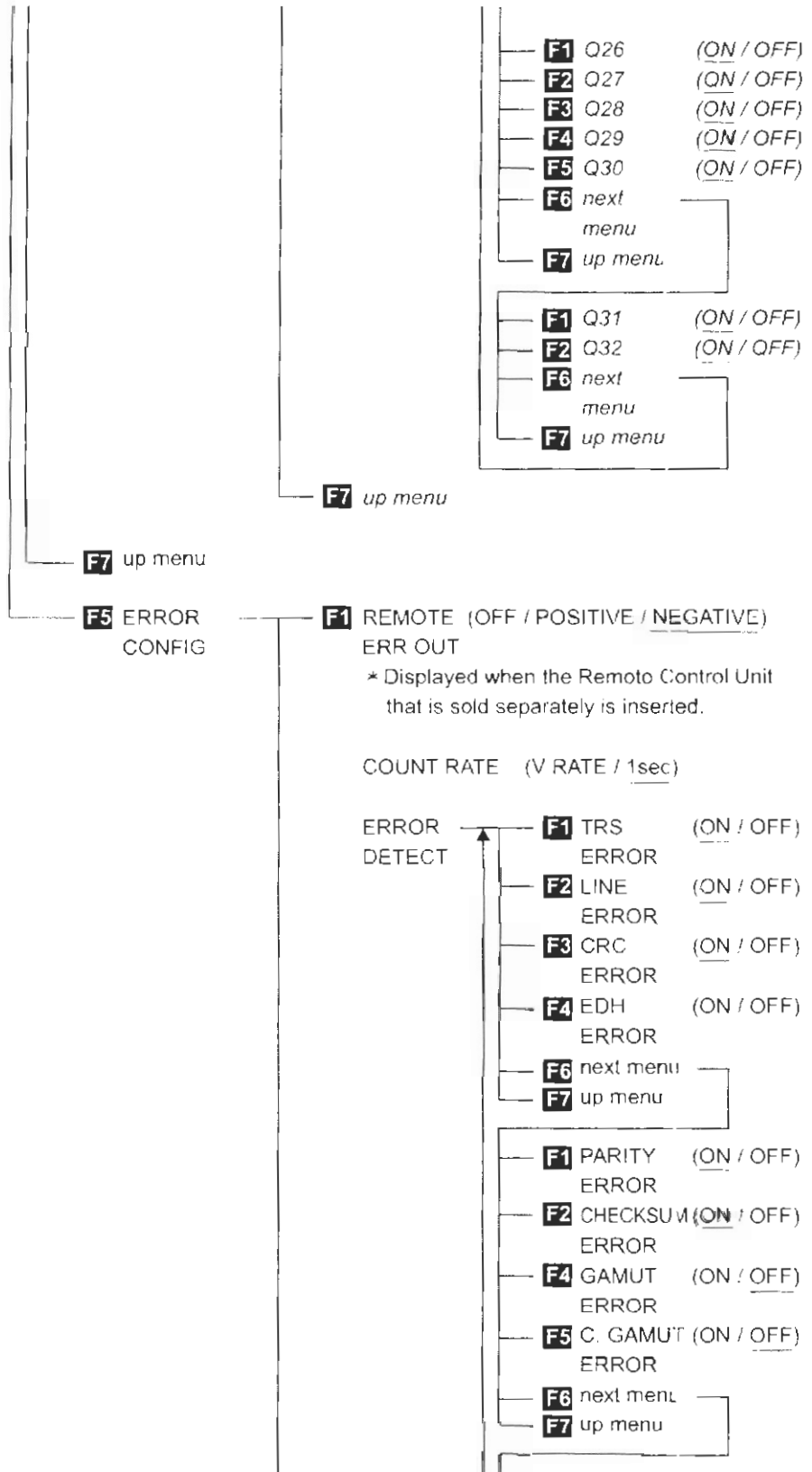

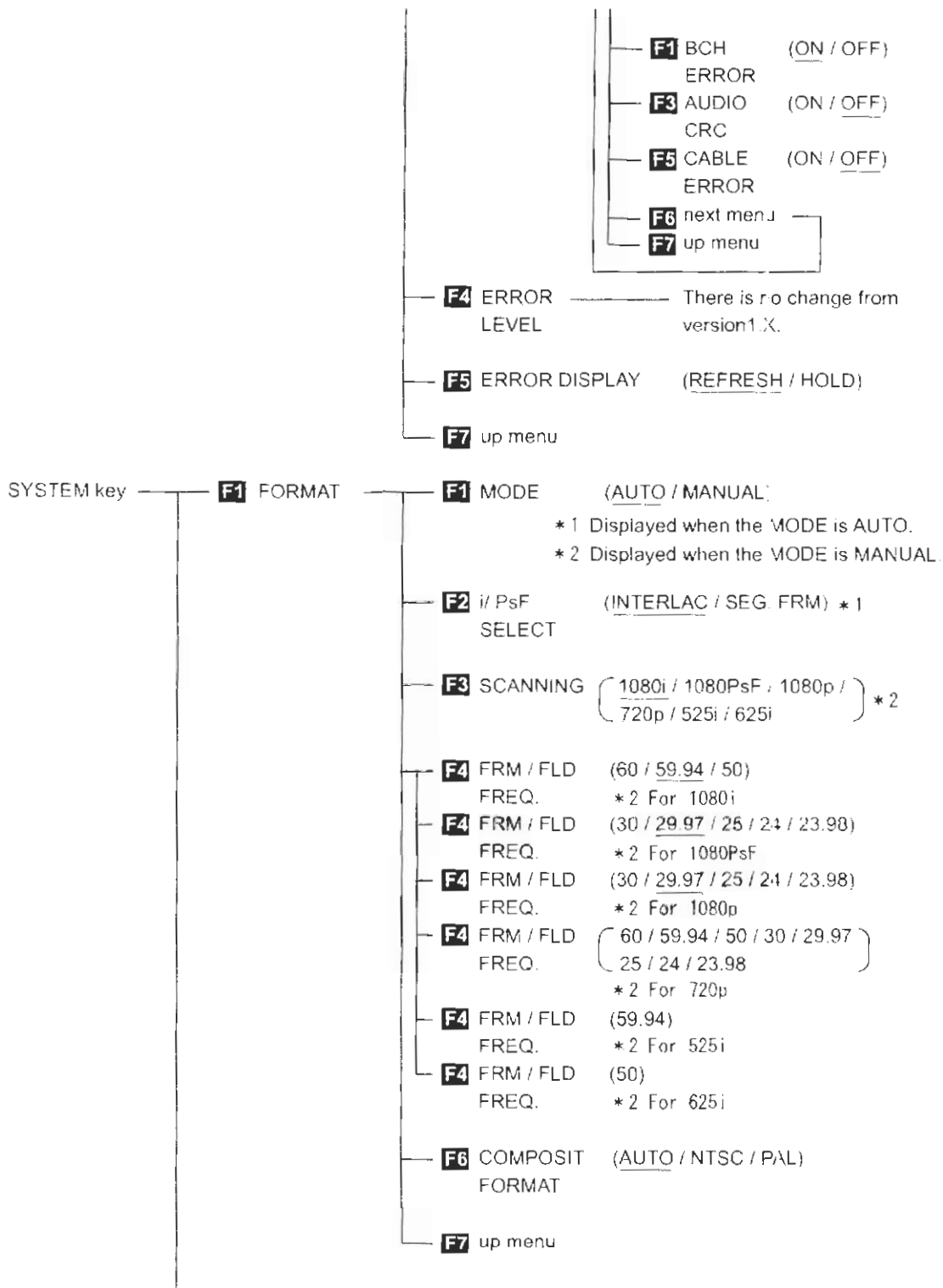

LV 5750 Addendum Instruction Manual

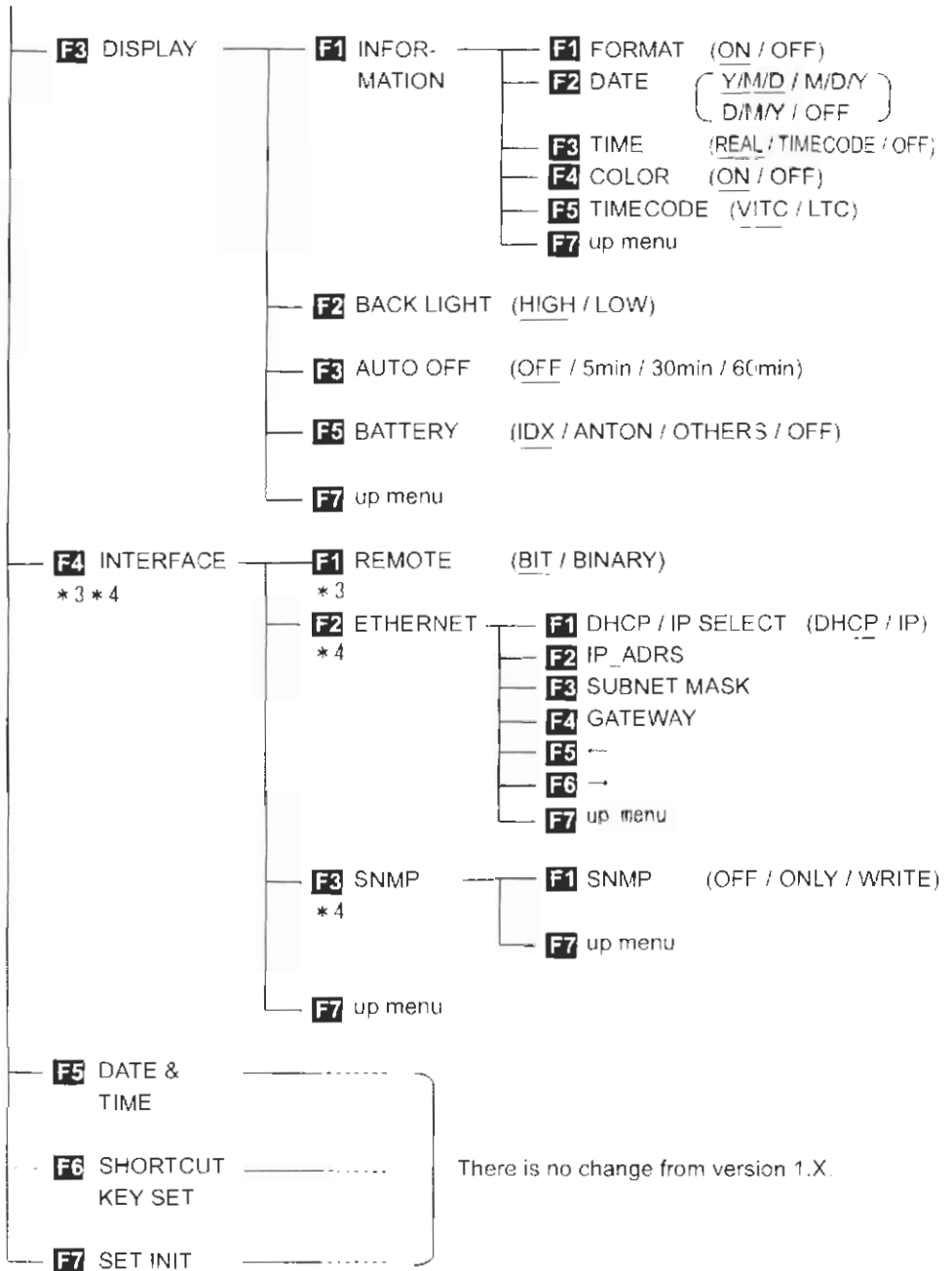

Menus indicated by *italics* are functions that are added when the LV 5750 firmware is upgraded from version 1.X. to 2.1.

* 3 Menu shown when the Remote Control Unit that is sold separately is inserted.

* 4 Menu shown when the Ethernet Unit that is sold separately is inserted.

4. SYSTEM CONFIGURATION

4.1 Additional Video Signal Formats

4.1.1 Video Signal Formats That Have Been Added

The 720p video signal formats 720p/50, 720p/30, 720p/29.97, 720p/25, 720p/24, and 720p/23.98 have been added to the conventional 720p/60 and 720p/59.94.

However, verifications have not been completed for 720p/30, 720p/29.97, 720p/25, 720p/24, and 720p/23.98 as of March 2005.

4.1.2 Video Signal Format Setting

(1) Auto Selection

[SYSTEM] → [F.1] FORMAT → [F.1] MODE : AUTO]

From the video signal format setup menu that appears by pressing the SYSTEM key followed by [F.1] FORMAT, press [F.1] MODE to select AUTO. The input SDI signal can be detected from the supported formats for an automatic setup.

(2) Manual Selection

[SYSTEM] → [F.1] FORMAT → [F.1] MODE : MANUAL]

From the video signal format setup menu that appears by pressing the SYSTEM key followed by [F.1] FORMAT, press [F.1] MODE to select MANUAL. You can manually set the signal among the supported video formats.

Here, if you press [F.3] SCANNING to select 720p, you can press [F.4] FRM/FLD
FREQ to select from the following:

[60 / 59.94 / 50 / 30 / 29.97 / 25 / 24 / 23.98]

For details on the video signal format settings, see section 5.4, "Video Signal Format Setting" in the LV 5750 Instruction Manual.

4.2 Time Code

The time code that is multiplexed in the SDI signal can be displayed in the time display area of the information display shown at the top section of the LV 5750 screen. You can select LTC or VITC as defined by SMPTE RP-188 to display the time code.

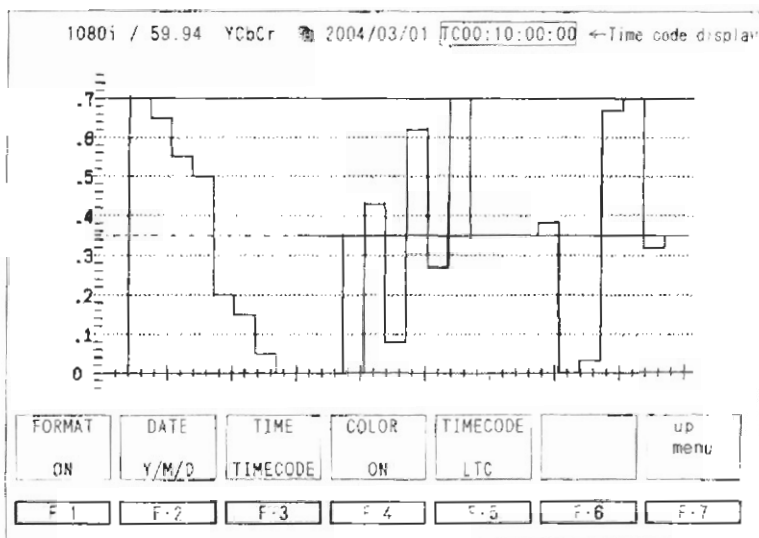

Figure 4-1 Time Code Display and Information Display Menu

4.2.1 Time Code Display

[**SYSTEM** → **F.3** DISPLAY → **F.1** INFORMATION → **F.3** TIME : REAL / TIMECODE / OFF]

To display the time code, press the SYSTEM key, press **F.3** DISPLAY, and then press **F.1** INFORMATION to show the information display menu. Then, press **F.3** TIME to select TIMECODE.

- REAL: Displays the current time (built-in real-time clock)
- TIMECODE: Displays the time code
- OFF: Does not display the time

4.2.2 LTC/VITC Selection

[**SYSTEM** → **F.3** DISPLAY → **F.1** INFORMATION → **F.5** TIMECODE : LTC / VITC]

You can select LTC or VITC as defined by SMPTE RP-188 to display the time code. To make the selection, press **F.5** TIMECODE from the information display menu to select LTC or VITC.

- LTC: Decodes and displays the LTC as defined by SMPTE RP-188.
- VITC: Decodes and displays the VITC as defined by SMPTE RF-188.

4.3 Remaining Battery Power Display

[**SYSTEM** → **F.3** DISPLAY → **F.4** BATTERY : IDX / ANTON / OTHERS / OFF]

The LV 5750 can display an approximate amount of remaining power in an IDX or Anton/Bauer battery.

To display the remaining battery power, press the SYSTEM key and press **F.3** DISPLAY.

From the display setup menu that appears, press **F.4** to specify the corresponding battery manufacturer. If you are using a battery from a manufacturer that is not listed, select OTHERS. In this case, the remaining power is not displayed.

IDX: Select this when using an IDX battery.

ANTON: Select this when using a Anton/Bauer battery.

OTHERS: Select this when using a battery other than IDX or Anton/Bauer. The remaining power is not displayed.

When the battery mount attachment type AC adaptor or the battery without an amount of remaining power output function is used, an amount of remaining power is not displayed correctly.

Therefore, selects OFF or OTHERS, and uses it so as not to display an amount of remaining power.

The remaining battery power is displayed using four level as shown below.

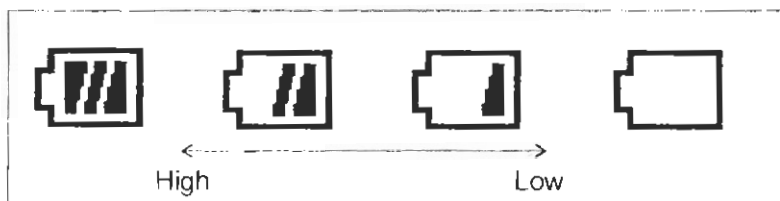

Figure 4-2 Remaining battery power display

4.4 SNMP Support

[**SYSTEM** → **F.4** INTERFACE → **F.3** SNMP → **F.1** SNMP : OFF / ONLY WRITE]

If the Ethernet Unit, an option sold separately, is installed in the LV 5750, error notification and remote control can be carried out using SNMP (Simple Network Management Protocol).

To use the SNMP function, press the SYSTEM key and press **F.4** INTERFACE.

From the interface setup menu that appears, press **F.3** SNMP.

Then, press **F.1** SNMP to disable or enable the SNMP in read-only mode or read/write mode.

- OFF: Disables the SNMP function.
- ONLY: Enables the SNMP in read-only mode.
- WRITE: Enables the SNMP in readable and writable mode.

The interface setup menu appears only when the Ethernet Unit, an option sold separately, is installed.

For details on how to use SNMP, see chapter 7, "SNMP Communication."

5. BAR DISPLAY

Peak levels of video signals can be displayed in place of the vectors.

The bar display that shows the peak levels can display five signals, intensity signal (Y), green (G), blue (B), red (R), and composite (COMP). The LV 5750 also operates in vectorscope mode to support multi screen display.

[**VECTOR**] → [**F·6**] SELECT → VECTOR / BAR]

To enable the bar display, press the VECTOR key to display the vector display menu. Then, press [**F·6**] SELECT to select BAR. If you select VECTOR, the vectorscope display is enabled.

The bar display of G, B, R, and COMP signals shows the levels through a matrix conversion of the Y, C_B, C_R of the SDI signal.

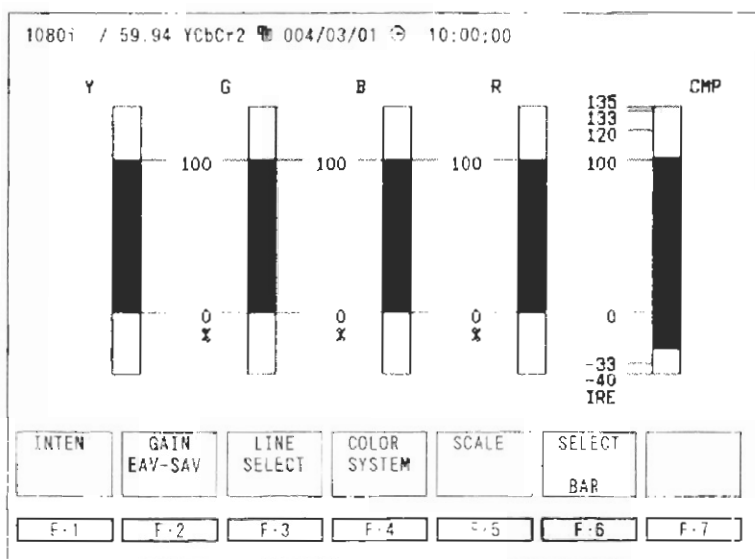

Figure 4-1 Bar display

5.1 Limit Setting

The bar display is normally shown in cyan, but the section exceeding the specified level is shown in red. The selectable range of limits is as follows:

Y Upper limit: The limit is fixed to 100% and cannot be changed.
 Lower limit: The limit is fixed to 0% and cannot be changed.

G,B,R Upper limit: The limit can be set in the range of 90.0 % to 109.4 %.
 Lower limit: The limit can be set in the range of -7.2 % to +6.0 %.
 The limit settings are linked to the gamut error threshold level.
 For the procedure to set the limit, see section 11.7.1 "Gamut Error Threshold Level" in the LV 5750 Instruction Manual.

CMP Upper limit: The limit can be set in the range of 90.0 % to 135.0 %.

Lower limit: The limit can be set in the range of -40.0 % to -20.0 %.

The limit settings are linked to the composite gamut error threshold level. For the procedure to set the limit, see section 11.7.2, "Composite Gamut Error Threshold Level" in the LV 5750 Instruction Manual.

5.2: Gamut Display Frequency Characteristics

To eliminate transient gamut errors such as overshoot on the bar display, the peak level is detected through a low pass filter with the following characteristics.

- HD-SDI: Approx. 5 MHz low pass filter
- SD-SDI: Approx. 1.8 MHz low pass filter

5.3 Miscellaneous

Detection is performed on all lines regardless of the line selector ON/OFF setting on the bar display.

5.4 Details of Bar Display

• Bar Display Contents

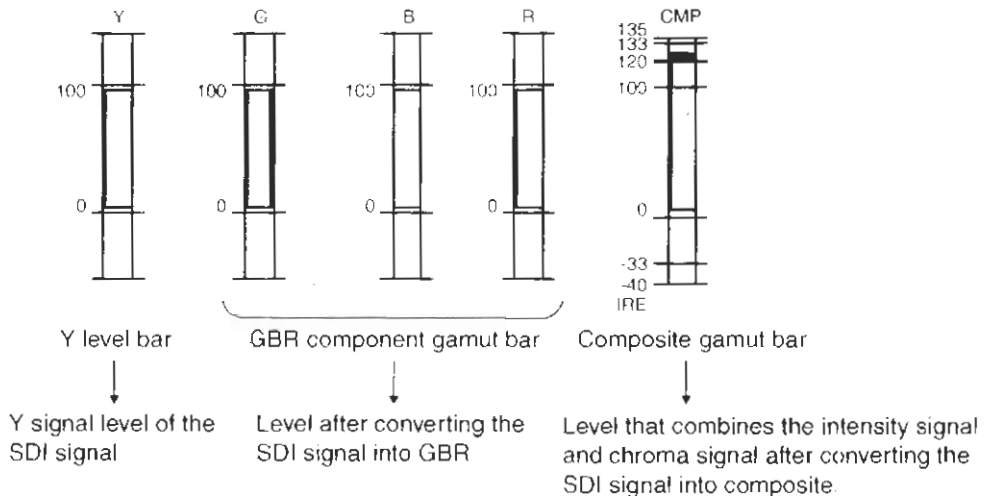

Figure 5-1 Bar display contents

• Component Bar Display Contents

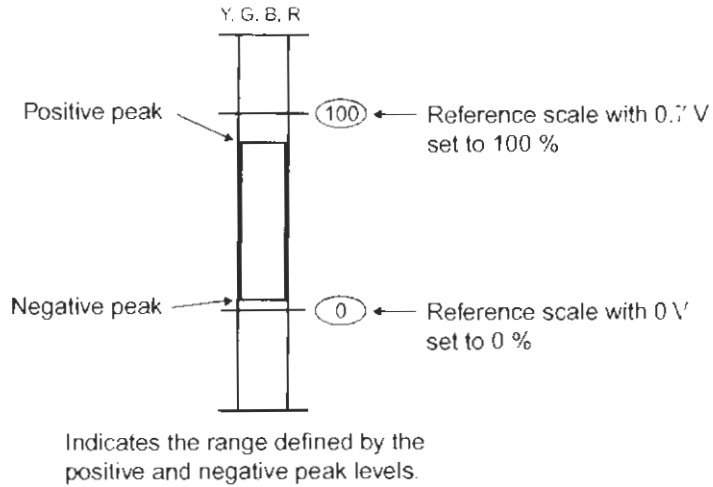

Figure 5-2 Bar display contents of component signal

• Composite Bar Display Contents

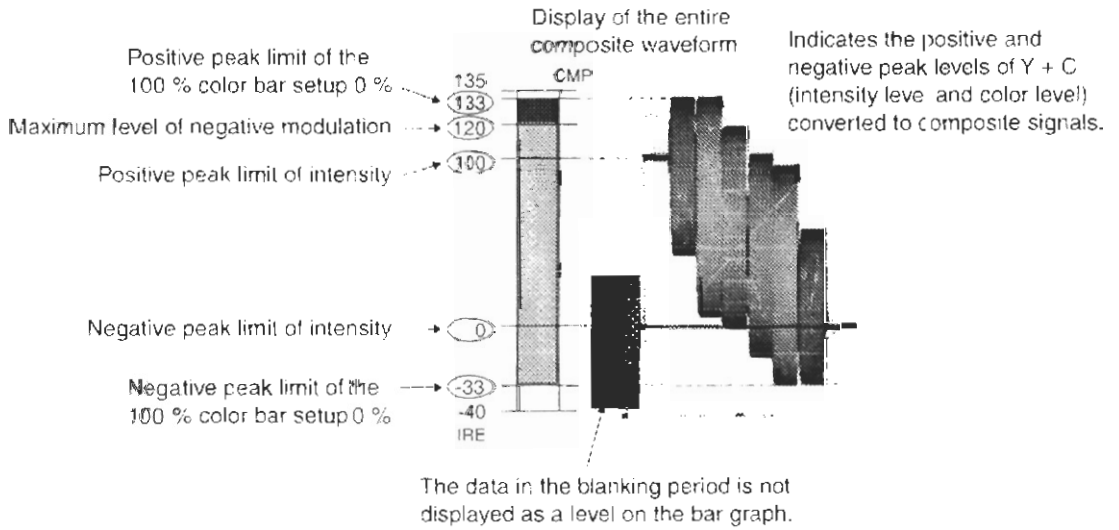

Figure 5-3 Bar display contents of composite signal

6. STATUS DISPLAY

6.1 Supplementary Information Concerning the Status Display

(1) Error Display

The status display shows "NORMAL" when there is no error in each measurement item and shows "ERROR" when an error occurs. When an error occurs, the "ERROR" display is held for 1 second.

(2) Compact Flash Card

When saving data such as error logs and data dumps to a compact flash card, use a card of a flash memory type.

Micro drives are not supported.

(3) EDH Error Detection

If the EDH error detection is turned ON while applying an SD-SDI signal and a TRS error occurs, the EDH item displays "----". If this happens and the TRS error detection is ON, the error is counted as a TRS error but not as an EDH error. In addition, EDH is not detected when a TRS error occurs regardless of whether the TRS error detection setting is ON or OFF.

(4) Reserved Area Error

The reserved area error is a measurement item that results in error when the data assigned to TRS or ADF such as 000h or 3FFh occurs outside a given area. The reserved area error also occurs when a TRS error occurs.

6.2 Audio CRC Detection Function

6.2.1 Status Display of the Audio CRC

A CRC error detection function of audio signals has been added to the status display that is shown when the STATUS key is pressed. The audio signal CRC error is detected by calculating the CRC of the channel status bits in the audio signal that is multiplexed in the SDI signal.

The audio CRC detection function is turned OFF by default.

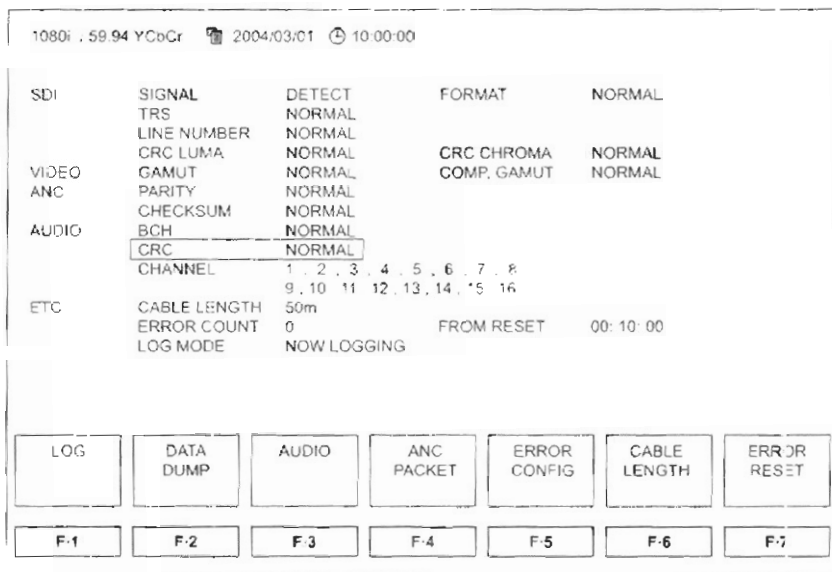

Figure 6-1 Status screen and status display menu

6.2.2 Event Log

The result of audio CRC detection can be logged to an event log. When an audio CRC error occurs, "CRC_ERR" is indicated in the area displaying the error information.

For details on event logs, see section 11.2, "Event Log" in the LV 5750 Instruction Manual.

6.2.3 Turning the Error Detection ON/OFF

[STATUS] → [F-5] ERROR CONFIG → [F-3] ERROR DETECT → [F-6] next menu → [F-6] next menu → [F-3] AUDIO CRC : ON / OFF]

The audio CRC detection function is turned OFF by default.

To start the error detection, press [F-5] ERROR CONFIG from the status display menu (press the STATUS key) of Figure 4-1. Then, press [F-3] ERROR DETECT and [F-6] next menu twice. Press [F-3] AUDIO CRC to select ON. If you select OFF, audio CRC errors are not detected.

6.3 V-ANC Monitor Function

6.3.1 ANC_PACKET Summary Display

[STATUS] → [F.4] ANC PACKET]

Press [F.4] ANC PACKET from the status display menu that appears by pressing the STATUS key to show the list of the presence/absence of ANC data that is detectable.

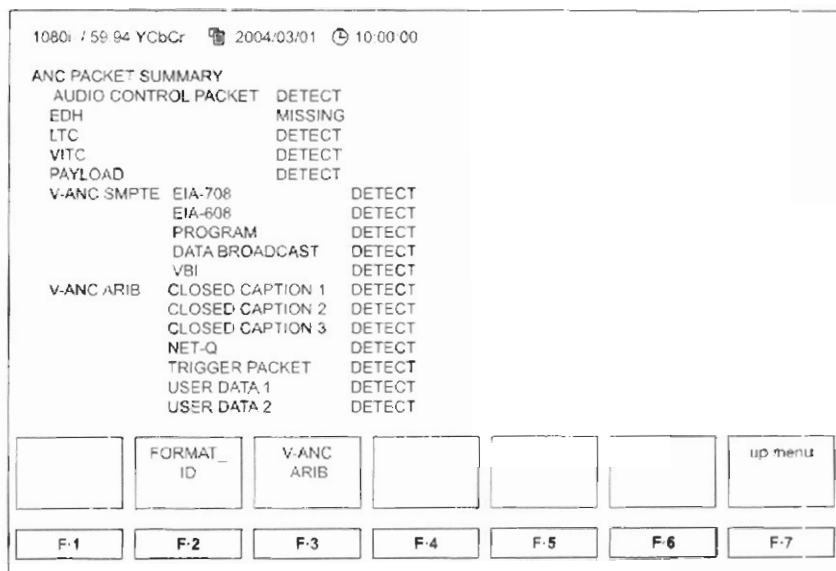

Figure 6.2 ANC Packet Detection Display and ANC Packet Menu

① AUDIO CONTROL PACKET

Control data for the embedded audio.

Multiplex line

- HD-SDI Line 9 and 571 of the Y channel
- SD-SDI Line 12 and 275

* Details of audio control packet are displayed using [STATUS] → [F.3] AUDIO.

② EDH (Error Detection and Handling)

Packet for detecting SD-SDI transmission errors.

When multiple devices are connected, this packet allows you to track the device in which the error occurred.

Error is detected on the full field and active picture.

Multiplex line

- 525/59.94 Line 9 and 272
- 625/50 Line 5 and 318

* Details of EDH are displayed using [STATUS] → [F.4] ANC PACKET → [F.1] EDH.

For HD-SDI, EDH does not display.

- ③ LTC (Linear/Longitudinal Time Code)
A type of time code that is multiplexed in the frame once.
Complies with the SMPTE RP-188 standard.

- ④ VITC (Vertical Interval Time Code)
A type of time code that is multiplexed in the field once.
Complies with the SMPTE RP-188 standard.

- ⑤ PAYLOAD (Payload ID)
A packet for identifying the SDI video signal format.
Complies with the SMPTE 352M-2002 standard.
* Details are displayed using STATUS → F·4 ANC PACKET · F·2
FORMAT_ID → F·1 PAKET SELECT : SMPTE/ARIB.

- ⑥ EIA-708
One of the closed caption standards of a U.S. system.
Closed caption data for digital video.
Multiplexed in the V-ANC area

- ⑦ EIA-608
One of the closed caption standards of a U.S. system.
Originally closed caption data for analog composite signals (multiplexed in line 21).
Multiplexed in the V-ANC area

- ⑧ PROGRAM (Program Description)
Mainly the program description standard of a U.S. system.
Multiplexed in the V-ANC area
Complies with the SMPTE 334M standard.

- ⑨ DATA BROADCAST
Mainly the data broadcast packet of a U.S. system.
Multiplexed in the V-ANC area
Complies with the SMPTE 334M standard.

- ⑩ VBI
Multiplexed in the V-ANC area
Complies with the SMPTE 334M standard.

⑪ CLOSED CAPTION 1,2,3

Closed caption information packet of a Japanese system multiplexed in the V-ANC area. Up to 3 closed caption data can be multiplexed.

Complies with the ARIB STD-B37 standard.

Multiplex line

- HD-SDI Line 19 and 582
- SD-SDI Line 18 and 281

⑫ NET-Q (Inter-Stationary Control Data)

NET-Q is called "Inter-Stationary Control Data".

Complies with the ARIB STD-B39 standard.

Multiplex line

- HD-SDI Line 20 and 583
- SD-SDI Line 19 and 282

⑬ TRIGGER PACKET

TRIGGER PACKET is called "Data Broadcast Trigger Signal".

Complies with the ARIB STD-B35 standard.

Multiplex line

- HD-SDI Line 20 and 583
- SD-SDI Line 19 and 282

⑭ USER DATA 1,2

As for the content of transmission, it is data not especially decided

Complies with the ARIB STD-B35 standard.

Multiplex line

- HD-SDI Line 20 and 583
- SD-SDI Line 19 and 282

6.3.2 Format ID Display

[STATUS] → [F.4] ANC PACKET → [F.2] FORMAT ID → [F.1] PACKET SELECT : SMPTE / ARIB]

The format ID is ANC data used to identify the video signal format. It is called PAYLOAD ID in the SMPTE specifications. The format ID on the LV 5750 can be set to SMPTE or ARIB. If SMPTE is selected, the PAYLOAD ID as defined by SMPTE 352 is displayed. If ARIB is selected, the current video mode that is included in the inter-stationary control data as defined by ARIB STD-B39 is displayed.

SMPTE: Displays the PAYLOAD ID as defined by SMPTE 352M

ARIB: Displays the current video mode as defined by ARIB STB-B39.

The format ID display is enabled by pressing [F.2] FORMAT ID from the ANC packet menu. Press [F.1] PACKET SELECT to switch between SMPTE and ARIB.

1080i / 59.94 YCbCr		2004/03/01	10:00:00
FORMAT ID DISPLAY SMPTE 352M			
BYTE1	10000111		
VERSION ID		SMPTE 352M-2002	
PAYLOAD ID		1128(1080) LINE	
DIGITAL INTERFACE		485Gb/s	
BYTE2	0000110		
TRANSPORT STRUCTURE		INTERLACED	
PICTURE STRUCTURE		INTERLACED	
PICTURE RATE		30:1.001	
BYTE3	00000010		
ASPECT RATIO		RESERVED	
H SAMPLING		RESERVED	
SAMPLING STRUCTURE		4 4 4 GBR	
BYTE4	00000001		
CHANNEL ASSIGNMENT		DUAL LINK A	
DYNAMIC RANGE		100%	
ASPECT RATIO			
MAPPING MODE			
BIT DEPTH		10BIT	

Figure 6.3 Format ID Display

Table 6-1 Description of the format ID display

Item	Description
BYTE1,2,3,4	The format ID consists of 4-byte data. This actual data is displayed in binary.
VERSION ID	Indicates the PAYLOAD ID version. Old version of packets are not supported.
PAYLOAD ID	Indicates the video format.
DIGITAL INTERFACE	Indicates the SDI bit rate.
TRANSPORT STRUCTURE	Indicates whether the digital interface uses a progressive or interlaced transport structure.
PICTURE STRUCTURE	Indicates whether the picture has been scanned as progressive or interlaced.
PICTURE RATE	Indicates the frame rate.
ASPECT RATIO	Indicates the image aspect ratio.
H SAMPLING	Indicates the number of horizontal Y samples.
SAMPLING STRUCTURE	Indicates the sampling structure.
CHANNEL ASSIGNMENT	Indicates the link during dual link
DYNAMIC RANGE	Indicates the dynamic range of a pixel. This is not used in the ARIB specifications.
ASPECT RATIO	Indicates the image aspect ratio. This is not used in the ARIB specifications.
MAPPING MODE	Indicates the mapping mode as defined by SMPTE 349M. This is not used in the ARIB specifications.
BIT DEPTH	Indicates the quantization accuracy of a pixel.

6.3.3 Closed Caption Data Display

[STATUS] → [F·4] ANC PACKET → [F·3] V-ANC ARIB → [F·1] CLOSED CAPTION]

An analysis (text) display of the header section and dump display of an entire packet can be shown for the digital closed caption packets as defined by ARIB STD-B37. In the ARIB standard, up the three types of digital closed caption packets can be multiplexed. One of the three types is selected and displayed.

If data dump is selected, you can select binary display or hexadecimal display.

To display the digital closed caption data, press [F·3] V-ANC ARIB from the ANC packet menu and press [F·1] CLOSED CAPTION.

(1) Selection of the Digital Closed Caption Type

Since up to three types of digital closed caption is multiplexed, select the type of digital closed caption you wish to display. Select 1, 2, or 3, which corresponds the order of the closed caption data that is multiplexed in the SDI signal.

Press [F·2] CAPTION NUMBER to select 1, 2, or 3.

(2) Switching between Text Display and Dump Display

To switch between text display and dump display, press **F-1** DISPLAY to select TEXT to enable the analysis display and DUMP to enable the dump display showing the entire packet.

(3) Dump Display Format

If the closed caption data display is set to dump, you can select the display format between binary and hexadecimal. Press **F-3** DUMP MODE to select BINARY for binary display or HEX for hexadecimal display.

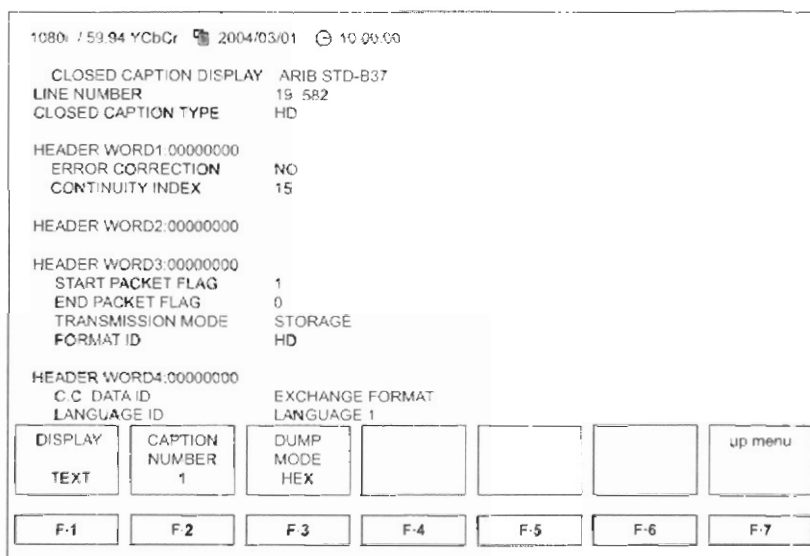

Figure 6-4 Text display of the closed caption and closed caption data menu

Table 6-2 Description of the closed caption packet display

Item	Description
LINE NUMBER	Indicates the line number to which the digital closed caption is multiplexed.
CLOSED CAPTION TYPE	Indicates the type of digital closed caption data.
ERROR CORRECTION	Indicates the availability of error correction.
CONTINUITY INDEX	A counter indicating the continuity of packets.
START PACKET FLAG	Indicates the start of the closed caption data group.
END PACKET FLAG	Indicates that the end TS packet is included when the packet is divided using MPEG-2 TS.
TRANSMISSION MODE	Indicates the transmission mode.
FORMAT ID	Indicates the type of digital closed caption packet.
C.C. DATA ID	Indicates the closed caption data ID.
LANGUAGE ID	Indicates the language ID used to send closed captions in multiple languages.

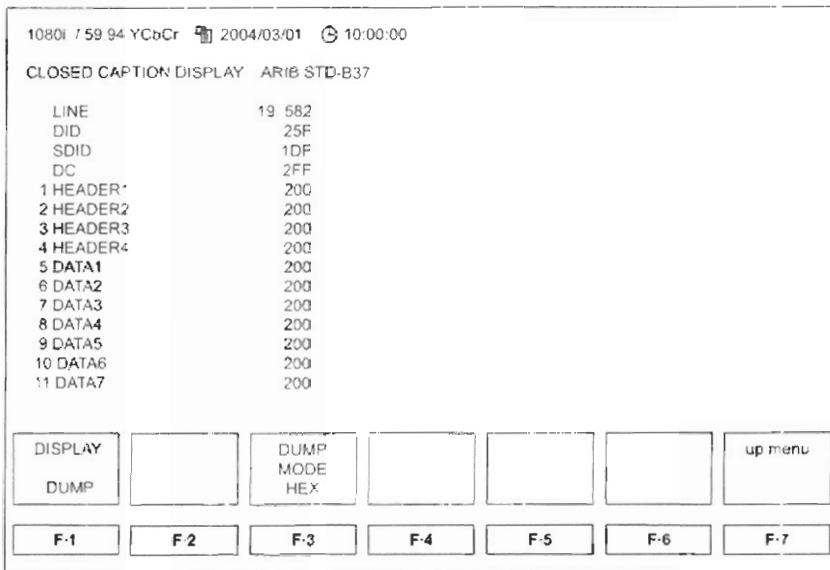

Figure 6-5 Closed Caption Data in Hexadecimal Notation Display

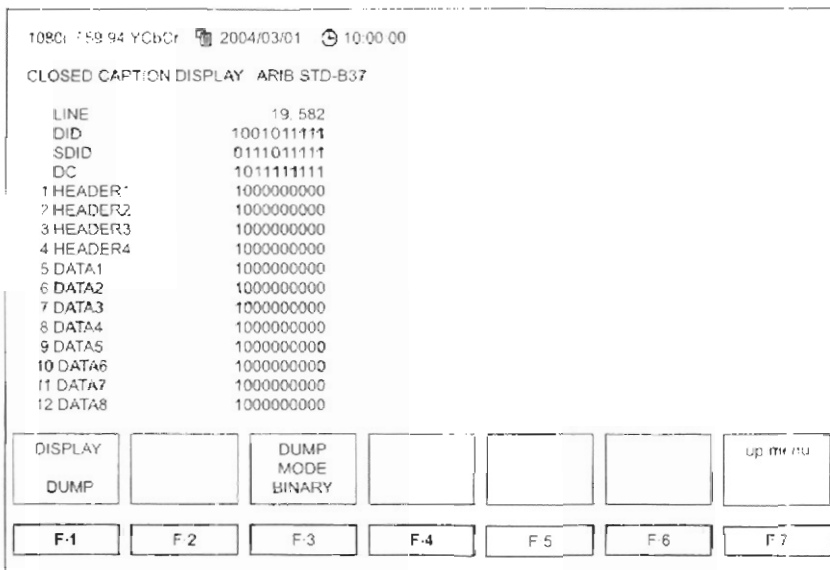

Figure 6-6 Closed Caption Data in Binary Notation Display

6.3.4 Inter-Stationary Control Signal

[STATUS] → [F·4 ANC PACKET] → [F·3 V-ANC ARIB] → [F·2 NET-Q]

An analysis (text) display of the dump display of an entire packet can be shown for the inter-stationary control signal as defined by ARIB STD-B39.

If data dump is selected, you can select binary display or hexadecimal display.

(1) Switching between Text Display and Dump Display

To switch between text display and dump display, press [F·1] DISPLAY to select TEXT to enable the analysis display and DUMP to enable the dump display showing the entire packet.

(2) Dump Display Format

If the [F·1] DISPLAY is set to dump, you can select the display format between binary and hexadecimal. Press [F·2] DUMP MODE to select BINARY for binary display or HEX for hexadecimal display.

(3) Turning the Q Signal ON/OFF

The Q bit 0/1 display of the TRIGGER SIGNAL can be turned ON/OFF independently on the text display screen. From the inter-stationary control menu, press [F·6] next menu. Then, press [F·1] to [F·5] to turn Q1 to Q32 ON/OFF independently.

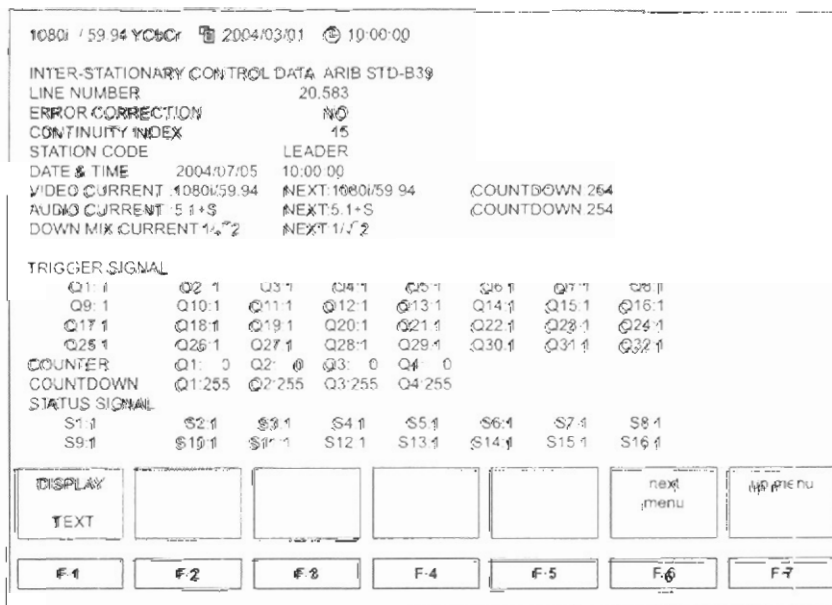

Figure 6-7 Inter-Stationary Control Signal Display and Inter-Stationary Control Menu

Table 6-3 Description of the inter-stationary control signal display

Item	Description
LINE NUMBER	Indicates the line number to which the inter-stationary control signal is multiplexed.
ERROR CORRECTION	Indicates the availability of error correction.
CONTINUITY INDEX	A counter indicating the continuity of packets.
STATION CODE	Indicates the originating station code. The code is expressed using alphabet characters or Japanese katakana.
DATE & TIME	Indicates the originating station time. Expressed with a date and time.
VIDEO CURRENT	Indicates the current video mode. For details, see section 6.3.2, "Format ID."
AUDIO CURRENT	Indicates the current audio mode.
NEXT	Indicates the next video/audio mode.
COUNTDOWN	Indicates the countdown of the video/audio mode switching.
DOWN MIX CURRENT	Indicates the current audio down mix designation.
NEXT	Indicates the next audio down mix designation.
TRIGGER SIGNAL	Indicates the trigger signal that represents the timing.
COUNTER	Indicates a count up to the required timing for Q1 to Q4 of the TRIGGER SIGNAL.
COUNTDOWN	Indicates a count down to the required timing for Q1 to Q4 of the TRIGGER SIGNAL.
STATUS SIGNAL	Indicates the status. The bit definitions are arbitrary.

(1) Data Dump Display (HEX)

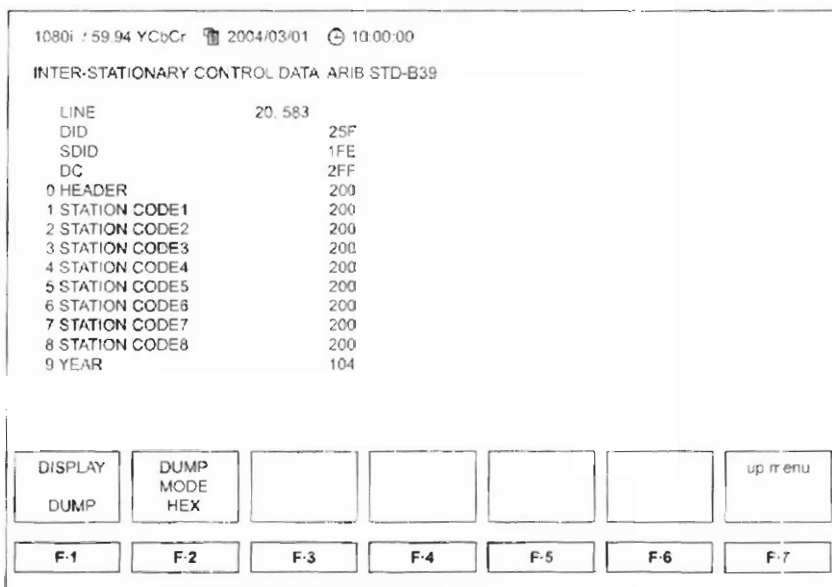

Figure 6-8 Inter-Stationary Control Signal in Hexadecimal Notation Display

(2) Data Dump Display (BIN)

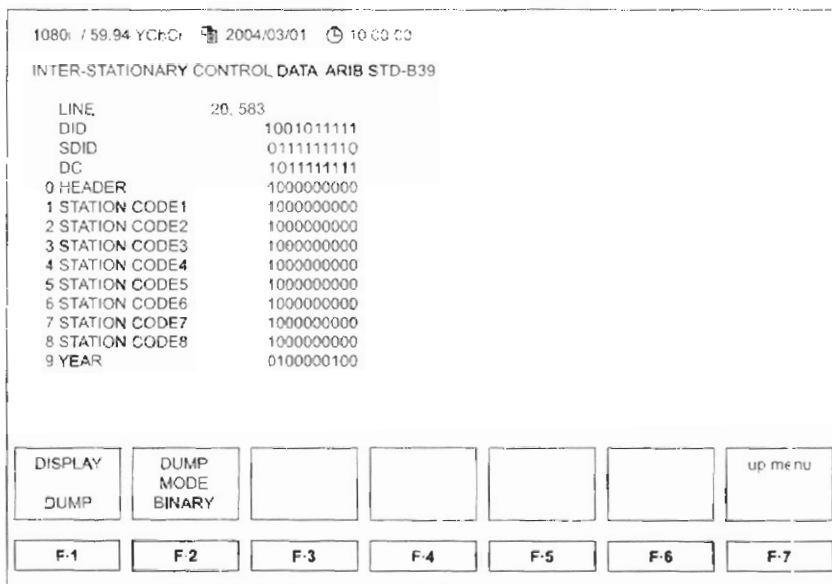

Figure 6-9 Inter-Stationary Control Signal in Binary Notation Display

6.4 Displaying Ancillary Data Markers Using Data Dump

This function detects ancillary data that is multiplexed in the SDI signal and indicates the code using markers.

The detected code is displayed in color as indicated in the following table making it extremely visible.

Detected Code	Color	Description
ADF	Cyan	Displays the 000H, 3FFH, 3FFH (ADF) code from the DATA_DUMP data.
DID	Cyan	The DID code is the next data after the ADF code.
SDID	Cyan	If the DID code is smaller than 80H, SDID is displayed as data in the second format.
DBN	Cyan	If the DID code is greater than or equal to 80H, DBN is displayed as data in the first format.
DC	Cyan	Displays the data count code (DC) following the SDID/DBN when the ADF code is detected.
UDW	Cyan	Displays the user data word (UDW) code: for the data count following the ADF code
CS	Magenta	Displays the CS code immediately after the UDW.
AP	Yellow	If the selected line is in the active picture area, the area between SAV and EAV are displayed as active picture AP area.

Table 6-10 Marker display of ancillary data

525i · 59.9 4 2004 / 03 0110:00:00			
DATA DUMP LINE No. 1			
	SAMPLE	COLOR	DATA
[EAV]	<1440>	Cb	3FF
[EAV]	<1441>	Y	000
[EAV]	<1442>	Cr	000
[EAV]	<1443>	Y	2D8
ADF	<1444>	Cb	000
ADF	<1445>	Y	3FF
ADF	<1446>	Cr	3FF
DID	<1447>	Y	2FF
DBN	<1448>	Cb	2C0
DC	<1449>	Y	224
UDW	<1450>	Cr	290
UDW	<1451>	Y	20D
UDW	<1452>	Cb	21F
UDW	<1453>	Y	292
UDW	<1454>	Cr	20D
UDW	<1455>	Y	11F

(a) Marker display around DID
(serial display)

525i · 59.94 2004 / 03 / 0110:00:00					
DATA DUMP LINE No. :					
	SAMPLE	Y	C. ADR	Cb	Cr
[EAV]	< 720>	000	<360>	3FF	000
[EAV]	< 721>	2D8			
ADF	ADF ADF < 722>	3FF	<361>	000	3FF
DID	< 723>	2FF			
DC	DBN DBN < 724>	224	<362>	2C0	290
UDW	< 725>	20D			
UDW	UDW UDW < 726>	292	<363>	21F	20D
UDW	< 727>	11F			
UDW	UDW UDW < 728>	20D	<364>	294	11F
UDW	< 729>	296			
UDW	UDW UDW < 730>	21F	<365>	20D	170
UDW	< 731>	1BC			
UDW	UDW UDW < 732>	172	<366>	21E	1BC
UDW	< 733>	11E			
UDW	UDW UDW < 734>	1BC	<367>	174	11E
UDW	< 735>	176			

(b) Marker display around DID
(component display)

525i / 59.9 / 4 2004 / 03 / 0110:00:00

DATA DUMP LINE No			
	SAMPLE	COLOR	DATA
UDW	<1484>	Cb	200
UDW	<1485>	Y	200
CS	<1486>	Cr	1E9
ADF	<1487>	Y	000
ADF	<1488>	Cb	3FF
ADF	<1489>	Y	3FF
DID	<1490>	Cr	1FE
DBN	<1491>	Y	26A
DC	<1492>	Cb	206
UDW	<1493>	Y	277
UDW	<1494>	Cr	177
UDW	<1495>	Y	2BB
UDW	<1496>	Cb	1BB
UDW	<1497>	Y	200
UDW	<1498>	Cr	00
CS	<1499>	Y	D2

(c) Marker display around CS
(serial display)

525i / 59.94 / 2004 / 03 / 0110:00:00

DATA DUMP LINE No 1			
	SAMPLE	COLOR	DATA
[SAV]	<1712>	Cb	3FF
[SAV]	<1713>	Y	000
[SAV]	<1714>	Cr	000
[SAV]	<1715>	Y	200
AP	< 0>	Cb	200
AP	< 1>	Y	040
AP	< 2>	Cr	200
AP	< 3>	Y	040
AP	< 4>	Cb	200
AP	< 5>	Y	042
AP	< 6>	Cr	200
AP	< 7>	Y	059
AP	< 8>	Cb	200
AP	< 9>	Y	006
AP	< 10>	Cr	200
AP	< 11>	Y	1FE

(d) Marker display around AP
(serial display)

Figure 6-10 Marker display screen of ancillary data

7. SNMP COMMUNICATION

7.1 Description

SNMP (Simple Network Protocol) can be used to control the LV 5750 and notify SDI signal errors.

The following sections describe how to set the LV 5750 and MIE (Management Information Base) when using SNMP.

NOTE: The SNMP function can be used only when the Ethernet Unit (LV 5750-01) that is an option sold separately is installed into the LV 5750.

7.2 SNMP Version Supported

The LV 5750 supports SNMPv1.

7.3 Setup

7.3.1 Configuring the SNMP Manager

An SNMP manager software application is required to use SNMP to control the LV 5750 from a PC or a similar device.

(The LV 5750 does not come with an SNMP manager software application.)

For the operating procedure of the manager, see the instruction manual for the SNMP manager that you are using.

1. Set the community name as follows:

Read Community: LDRUser
Write Community: LDRAdm

2. SMI Definitions

```
IMPORTS
MODULE-IDENTITY, OBJECT-TYPE, NOTIFICATION-TYPE, enterprises
FROM SNMPv2-SMI
DisplayString
FROM SNMPv2-TC
OBJECT-GROUP, MODULE-COMPLIANCE
FROM SNMPv2-CONF;
```

7.3.2 Setting the LV 5750

1. Set the IP address (see chapter 15, "Ethernet").
2. From the **SYSTEM** menu, **F·4** INTERFACE → **F·3** SNMP → **F·1** SNMP READ WRITE.

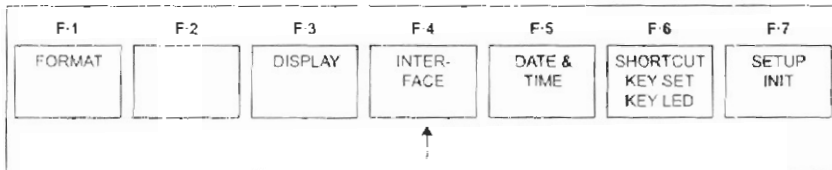

Figure 7-1 System Setting Menu

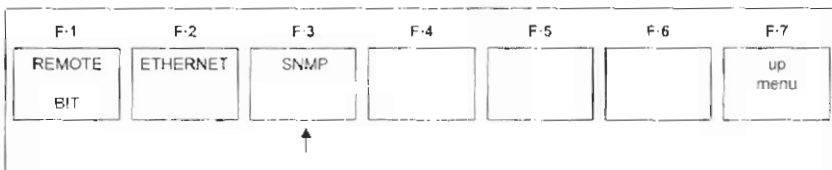

Figure 7-2 Interface Setting Menu

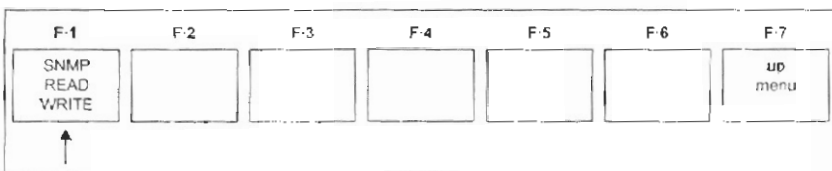

Figure 7-3 SNMP Setting Menu

3. Turn off the LV 5750 and back on.
4. Check that GET and SET operations can be carried out from the SNMP manager.
5. Carry out a SET operation from the SNMP manager to assign the IP address of the SNMP manager to the MIB object below.

"1.3.6.1.4.1.leader(2011).lv5750(1).lv5750_st(1).trapTBL(11).trapManagerIp(2).o"

6. Restart the LV 5750.
7. The standard SNMP trap "coldStart(0)" is sent when the LV 5750 starts up. Check that the trap is received by the SNMP manager.

7.4 MIB (Management Information Base)

This section describes the MIB (Management Information Base) that the LV 5750 uses.

7.4.1 Standard MIB

The LV 5750 uses the standard MIB listed below.

- RFC1213 (MIB- II)
- RFC1354 (IP Forwarding Table MIB)

7.4.1.1 Standard MIB Functions

This section describes the standard MIB objects that are implemented on the LV 5750.

Note that this version does not support some objects (those marked as "No" under the S column).

The indications in the ACCESS column in the tables are defined as follows:

- R	Information that can be retrieved using the SNMP manager.
- RW	Information that can be retrieved and set using the SNMP manager.
- RWO	Information that can be retrieved and set using the SNMP manager. However, the retrieved data is a fixed value with no meaning.

The indications in the S column in the tables are defined as follows:

- Yes	Supported as defined by the standard.
- △	Only read is supported by the LV 5750 even though read and write are possible according to the standard.
- No	Not supported.

MIB- I (RFC1213)

system group

MIB	OID	SYNTAX	ACCESS	S
sysDescr	system.1	DisplayString	R	○
sysObjectID	system.2	ObjectID	R	○
sysUpTime	system.3	TimeTicks	R	○
sysContact *1	system.4	DisplayString	R/W	○
sysName *1	system.5	DisplayString	R/W	○
sysLocation *1	system.6	DisplayString	R/W	○
sysServices	system.7	INTEGER	R	○

*1 Set using up to 40 bytes.

interface group

MIB	OID	SYNTAX	ACCESS	S
ifNumber	interfaces.1	INTEGER	R	○
ifTable	interfaces.2	Aggregate	--	○
ifEntry	ifTable.1	Aggregate	--	○
ifIndex	ifEntry.1	INTEGER	R	○
ifDescr	ifEntry.2	DisplayString	R	○
ifType	ifEntry.3	INTEGER	R	△
ifMtu	ifEntry.4	INTEGER	R	△
ifSpeed	ifEntry.5	Gauge	R	○
ifPhysAddress	ifEntry.6	OctetString	R	○
ifAdminStatus	ifEntry.7	INTEGER	R	○
ifOperStatus	ifEntry.8	INTEGER	R	○
ifLastChange	ifEntry.9	TimeTicks	R	○
ifInOctets	ifEntry.10	Counter	R	○
ifInUcastPkts	ifEntry.11	Counter	R	○
ifInNUcastPkts	ifEntry.12	Counter	R	○
ifInDiscards	ifEntry.13	Counter	R	○
ifInErrors	ifEntry.14	Counter	R	○
ifInUnknownProtos	ifEntry.15	Counter	R	○
ifOutOctets	ifEntry.16	Counter	R	○
ifOutUcastPkts	ifEntry.17	Counter	R	○
ifOutNUcastPkts	ifEntry.18	Counter	R	○
ifOutDiscards	ifEntry.19	Counter	R	○
ifOutErrors	ifEntry.20	Counter	R	○
ifOutQLen	ifEntry.21	Gauge	R	○
ifSpecific	ifEntry.22	ObjectID	R	○

ip group (RFC1354)

MIB	OID	SYNTAX	ACCESS	S
ipForwarding	ip.1	INTEGER	R	○
ipDefaultTTL	ip.2	INTEGER	R	○
ipInReceives	ip.3	Counter	R	○
ipInHdrErrors	ip.4	Counter	R	○
ipInAddrErrors	ip.5	Counter	R	○
ipFonyDatagrams	ip.6	Counter	R	○
ipInUnknownProtos	ip.7	Counter	R	○
ipInDiscards	ip.8	Counter	R	○
ipInDelivers	ip.9	Counter	R	○
ipOutRequests	ip.10	Counter	R	○
ipOutDiscards	ip.11	Counter	R	○
ipOutNoRoutes	ip.12	Counter	R	○
ipReasmTimeout	ip.13	INTEGER	R	○
ipReasmReqds	ip.14	Counter	R	○
ipReasmOKs	ip.15	Counter	R	○
ipReasmFails	ip.16	Counter	R	○
ipFragOKs	ip.17	Counter	R	○
ipFragFails	ip.18	Counter	R	○
ipFragCreates	ip.19	Counter	R	○
ipAddrTable	ip.20	Aggregate	--	○
ipAddrEntry	ipAddrTable.1	Aggregate	--	○
ipAdEntAddr	ipAddrEntry.1	IpAddress	R	○
ipAdEntIfIndex	ipAddrEntry.2	INTEGER	R	○
ipAdEntNetMask	ipAddrEntry.3	IpAddress	R	○
ipAdEntBcastAddr	ipAddrEntry.4	INTEGER	R	○
ipAdEntReasmMaxSize	ipAddrEntry.5	INTEGER	R	○
ipNetToMediaTable	ip.22	Aggregate	--	○
ipNetToMediaEntry	ipNetToMediaTable.1	Aggregate	--	○
ipNetToMediaIfIndex	ipNetToMediaEntry.1	INTEGER	R	△
ipNetToMediaPhysAddress	ipNetToMediaEntry.2	OctetString	R	△
ipNetToMediaNetAddress	ipNetToMediaEntry.3	IpAddress	R	△
ipNetToMediaType	ipNetToMediaEntry.4	INTEGER	R	△
ipRoutingDiscards	ip.23	Counter	R	○
ipForward	ip.24	Aggregate	--	○
ipForwardNumber	ipForward.1	Gauge	R	○
ipForwardTable	ipForward.2	Aggregate	--	○
ipForwardDest	ipForwardTable.1	IpAddress	R	○
ipForwardMask	ipForwardTable.1	IpAddress	R	○
ipForwardPolicy	ipForwardTable.1	INTEGER	R	×

LV 5750 Addendum Instruction Manual

MIB	OID	SYNTAX	ACCESS	S
ipForwardNextHop	ipForwardTable.1	IpAddress	R	○
ipForwardIfIndex	ipForwardTable.1	INTEGER	R	○
ipForwardType	ipForwardTable.1	INTEGER	R	×
ipForwardProto	ipForwardTable.1	INTEGER	R	×
ipForwardAge	ipForwardTable.1	INTEGER	R	×
ipForwardInfo	ipForwardTable.1	ObjectID	R	×
ipForwardNextHopAS	ipForwardTable.1	INTEGER	R	×
ipForwardMetric1	ipForwardTable.1	INTEGER	R	×
ipForwardMetric2	ipForwardTable.1	INTEGER	R	×
ipForwardMetric3	ipForwardTable.1	INTEGER	R	×
ipForwardMetric4	ipForwardTable.1	INTEGER	R	×
ipForwardMetric5	ipForwardTable.1	INTEGER	R	×

icmp group

MIB	OID	SYNTAX	ACCESS	S
icmpInMsgs	icmp.1	Counter	R	○
icmpInErrors	icmp.2	Counter	R	○
icmpInDestUnreachs	icmp.3	Counter	R	○
icmpInTimeExcds	icmp.4	Counter	R	○
icmpInParmProbs	icmp.5	Counter	R	○
icmpInSrcQuenchs	icmp.6	Counter	R	○
icmpInRedirects	icmp.7	Counter	R	○
icmpInEchos	icmp.8	Counter	R	○
icmpInEchoReps	icmp.9	Counter	R	○
icmpInTimestamps	icmp.10	Counter	R	○
icmpInTimestampReps	icmp.11	Counter	R	○
icmpInAddrMasks	icmp.12	Counter	R	○
icmpInAddrMaskReps	icmp.13	Counter	R	○
icmpOutMsgs	icmp.14	Counter	R	○
icmpOutErrors	icmp.15	Counter	R	○
icmpOutDestUnreachs	icmp.16	Counter	R	○
icmpOutTimeExcds	icmp.17	Counter	R	○
icmpOutParmProbs	icmp.18	Counter	R	○
icmpOutSrcQuenchs	icmp.19	Counter	R	○
icmpOutRedirects	icmp.20	Counter	R	○
icmpOutEchos	icmp.21	Counter	R	○
icmpOutEchoReps	icmp.22	Counter	R	○
icmpOutTimestamps	icmp.23	Counter	R	○
icmpOutTimestampReps	icmp.24	Counter	R	○

MIB	OID	SYNTAX	ACCESS	S
icmpOutAddrMasks	icmp.25	Counter	R	○
icmpOutAddrMaskReps	icmp.26	Counter	R	○

tcp group

MIB	OID	SYNTAX	ACCESS	S
tcpRtoAlgorithm	tcp.1	INTEGER	R	○
tcpRtoMin	tcp.2	INTEGER	R	○
tcpRtoMax	tcp.3	INTEGER	R	○
tcpMaxConn	tcp.4	INTEGER	R	○
tcpActiveOpens	tcp.5	Counter	R	○
tcpPassiveOpens	tcp.6	Counter	R	○
tcpAttemptFails	tcp.7	Counter	R	○
tcpEstabResets	tcp.8	Counter	R	○
tcpCurrEstab	tcp.9	Gauge	R	○
tcpInSegs	tcp.10	Counter	R	○
tcpOutSegs	tcp.11	Counter	R	○
tcpRetransSegs	tcp.12	Counter	R	○
tcpConnTable	tcp.13	Aggregate	--	○
tcpConnEntry	tcpConnTable.1	Aggregate	--	○
tcpConnState	tcpConnEntry.1	INTEGER	R	△
tcpConnLocalAddress	tcpConnEntry.2	IpAddress	R	○
tcpConnLocalPort	tcpConnEntry.3	INTEGER	R	○
tcpConnRemAddress	tcpConnEntry.4	IpAddress	R	○
tcpConnRemPort	tcpConnEntry.5	INTEGER	R	○
tcpInErrs	tcp.14	Counter	R	○
tcpOutRsts	tcp.15	Counter	R	○

udp group

MIB	OID	SYNTAX	ACCESS	S
udpInDatagrams	udp.1	Counter	R	○
udpNoPorts	udp.2	Counter	R	○
udpInErrors	udp.3	Counter	R	○
udpOutDatagrams	udp.4	Counter	R	○
udpTable	udp.5	Aggregate	--	○
udpEntry	udpTable.1	Aggregate	--	○
udpLocalAddress	udpEntry.1	IpAddress	R	○
udpLocalPort	udpEntry.2	INTEGER	R	○

snmp_group

MIB	OID	SYNTAX	ACCESS	S
snmp.InPkts	snmp.1	Counter	R	○
snmp.OutPkts	snmp.2	Counter	R	○
snmp.InBadVersions	snmp.3	Counter	R	○
snmp.InBadCommunityNames	snmp.4	Counter	R	○
snmp.InBadCommunityUses	snmp.5	Counter	R	○
snmp.InASNParseErrs	snmp.6	Counter	R	○
snmp.InTooBigs	snmp.8	Counter	R	○
snmp.InNoSuchNames	snmp.9	Counter	R	○
snmp.InBadValues	snmp.10	Counter	R	○
snmp.InReadOnlys	snmp.11	Counter	R	○
snmp.InGenErrs	snmp.12	Counter	R	○
snmp.InTotalReqVars	snmp.13	Counter	R	○
snmp.InTotalSetVars	snmp.14	Counter	R	○
snmp.InGetRequests	snmp.15	Counter	R	○
snmp.InGetNexts	snmp.16	Counter	R	○
snmp.InSetRequests	snmp.17	Counter	R	○
snmp.InGetResponses	snmp.18	Counter	R	○
snmp.InTraps	snmp.19	Counter	R	○
snmp.OutTooBigs	snmp.20	Counter	R	○
snmp.OutNoSuchNames	snmp.21	Counter	R	○
snmp.OutBadValues	snmp.22	Counter	R	○
snmp.OutGenErrs	snmp.24	Counter	R	○
snmp.OutGetRequests	snmp.25	Counter	R	○
snmp.OutGetNexts	snmp.26	Counter	R	○
snmp.OutSetRequests	snmp.27	Counter	R	○
snmp.OutGetResponses	snmp.28	Counter	R	○
snmp.OutTraps	snmp.29	Counter	R	○
snmp.EnableAuthenTraps	snmp.30	IpAddress	R/W	○

7.4.2 Enterprise MIB

The enterprise number of Leader Electronics Corporation is 20111.

Iso①.org③.dod⑥.internet①.private④.enterprises①.leader(20111)

7.4.2.1 Retrieving the Enterprise MIB File

Download the file on the LV 5750 using FTP.

The file name is "lv5750.my".

For a description of how to use FTP, see section 15-3-2, "FTP File Transfer" in the LV 5750 Instruction Manual.

7.4.2.2 Enterprise MIB Structure

The enterprise MIB structure is shown below.

Leader	OBJECT IDENTIFIER	::= { enterprises 20111 }	
lv5750	OBJECT IDENTIFIER	::= { leader 1 }	
lv5750_ST1	OBJECT IDENTIFIER	::= { lv5750 1 }	
panel	OBJECT IDENTIFIER	::= { lv5750_ST1 1 }	<-- PANEL key
wfm	OBJECT IDENTIFIER	::= { lv5750_ST1 2 }	<-- W/FM menu
vector	OBJECT IDENTIFIER	::= { lv5750_ST1 3 }	<-- VECTOR menu
picture	OBJECT IDENTIFIER	::= { lv5750_ST1 4 }	<-- PICTURE menu
audio	OBJECT IDENTIFIER	::= { lv5750_ST1 5 }	<-- AUDIO menu
multi	OBJECT IDENTIFIER	::= { lv5750_ST1 6 }	<-- MULTI menu
status	OBJECT IDENTIFIER	::= { lv5750_ST1 7 }	<-- STATUS menu
capture	OBJECT IDENTIFIER	::= { lv5750_ST1 8 }	<-- CAPTUE menu
files	OBJECT IDENTIFIER	::= { lv5750_ST1 9 }	<-- FILE creation
system	OBJECT IDENTIFIER	::= { lv5750_ST1 10 }	<-- SYSTEM menu
trap	OBJECT IDENTIFIER	::= { lv5750_ST1 11 }	<-- Trap information

7.4.2.3 Enterprise MIBs

* The prefix "l3" in the table is the lowercase of L3.

Tree Structure of the Enterprise MIB is shown below.

leader	OBJECT IDENTIFIER	::= { enterprises 20111 }
lv5750	OBJECT IDENTIFIER	::= { leader 1 }
lv5750_ST1	OBJECT IDENTIFIER	::= { lv5750 1 }
l3panelTBL	OBJECT IDENTIFIER	::= { lv5750_ST1 1 }
l3wfmTBL	OBJECT IDENTIFIER	::= { lv5750_ST1 2 }
l3vectorTBL	OBJECT IDENTIFIER	::= { lv5750_ST1 3 }
l3pictureTBL	OBJECT IDENTIFIER	::= { lv5750_ST1 4 }
l3audioTBL	OBJECT IDENTIFIER	::= { lv5750_ST1 5 }
l3multiTBL	OBJECT IDENTIFIER	::= { lv5750_ST1 6 }
l3statusTBL	OBJECT IDENTIFIER	::= { lv5750_ST1 7 }
l3captureTBL	OBJECT IDENTIFIER	::= { lv5750_ST1 8 }
l3filesTBL	OBJECT IDENTIFIER	::= { lv5750_ST1 9 }
l3systemTBL	OBJECT IDENTIFIER	::= { lv5750_ST1 10 }
l3trapTBL	OBJECT IDENTIFIER	::= { lv5750_ST1 11 }

I3panelTBL (1) group

MIB	OID	SYNTAX	ACCESS	Value/Range
I3plSDI	I3panelTBL.2	INTEGER	R/W	0 = SDI A 1 = SDI B
I3plReference	I3panelTBL.3	INTEGER	R/W	0 = INT 1 = EXT
I3plMode	I3panelTBL.4	INTEGER	R/W	0 = OVERLAY 1 = PARADE 2 = TIMING
I3plAudChTBL	I3panelTBL.5	Aggregate	--	--
I3plCH1	I3plAudChTBL.1	INTEGER	R/W	0 = off 1 = on
I3plCH2	I3plAudChTBL.2	INTEGER	R/W	0 = off 1 = on
I3plCH3	I3plAudChTBL.3	INTEGER	R/W	0 = off 1 = on
I3plDisplay	I3panelTBL.6	INTEGER	R/W	0 = WFM 1 = Vector 2 = Audio 3 = Picture 4 = Multi 5 = Status 6 = Capture 7 = System 8 = Memory 10 = Recall

I3wfmTBL (2) group

MIB	OID	SYNTAX	ACCESS	Value/Range
I3wfmIntenTBL	I3wfmTBL.1	Aggregate	--	--
I3wfmIntenWfm	I3wfmIntenTBL.1	INTEGER	R/W	-128 to 127
I3wfmIntenSCALE	I3wfmIntenTBL.2	INTEGER	R/W	-8 to 7
I3wfmGainTBL	I3wfmTBL.2	Aggregate	--	--
I3wfmGainVAR	I3wfmGainTBL.1	INTEGER	R/W	0 = Cal 1 = Var
I3wfmGainMAG	I3wfmGainTBL.2	INTEGER	R/W	0 = X1 1 = X5
I3wfmGainFILTER	I3wfmGainTBL.3	INTEGER	R/W	0 = FLAT 1 = LOW-PASS
I3wfmGainCFILTER	I3wfmGainTBL.4	INTEGER	R/W	0 = FLAT 1 = FLAT-LUM
I3wfmSweepTBL	I3wfmTBL.3	Aggregate	--	--
I3wfmSweepSweep	I3wfmSweepTBL.1	INTEGER	R/W	0 = H 1 = V
I3wfmSweepHSweep	I3wfmSweepTBL.2	INTEGER	R/W	0 = 1H 1 = 2H
I3wfmSweepVSweep	I3wfmSweepTBL.3	INTEGER	R/W	0 = 1V 1 = 2V
I3wfmSweepField	I3wfmSweepTBL.4	INTEGER	R/W	0 = field1 1 = field2
I3wfmSweepHMAG	I3wfmSweepTBL.5	INTEGER	R/W	0 = X1 1 = X10 2 = X20 3 = Active 4 = Blank
I3wfmSweepVMAG	I3wfmSweepTBL.6	INTEGER	R/W	0 = X1 1 = X20 2 = X40
I3wfmLineSelectTBL	I3wfmTBL.4	Aggregate	--	--
I3wfmLineSelect	I3wfmLineSelectTBL.1	INTEGER	R/W	0 = off 1 = on
I3wfmLineSelectNumber	I3wfmLineSelectTBL.2	INTEGER	R/W	1 to 1125
I3wfmLineSelectField	I3wfmLineSelectTBL.3	INTEGER	R/W	0 = FIELD1 1 = FIELD2 2 = FRAME
I3wfmColorTBL	I3wfmTBL.5	Aggregate	--	--

MIB	OID	SYNTAX	ACCESS	Value/Range
l3wfmColorMatrix	l3wfmColorTBL.1	INTEGER	R/W	0 = YCBCR 1 = GBR 2 = RGB 3 = COMPOSITE
l3wfmColorYGBR	l3wfmColorTBL.2	INTEGER	R/W	0 = off 1 = on
l3wfmColorYRGB	l3wfmColorTBL.3	INTEGER	R/W	0 = off 1 = on
l3wfmColorSetup	l3wfmColorTBL.4	INTEGER	R/W	0 = 0% 1 = 7.5%
l3wfmScaleTBL	l3wfmTBL.6	Aggregate	--	--
l3wfmScaleUnit	l3wfmScaleTBL.1	INTEGER	R/W	0 = HDV SD% 1 = HDV SDV 2 = HD% SD%
l3wfmScaleColor	l3wfmScaleTBL.3	INTEGER	R/W	0 = White 1 = Yellow 2 = Cyan 3 = Green 4 = Magenta 5 = Red 6 = Blue
l3wfmScaleColor75P	l3wfmScaleTBL.4	INTEGER	R/W	0 = off 1 = on
l3wfmEavSav	l3wfmTBL.7	INTEGER	R/W	0 = Remove 1 = Pass
l3wfmTimingMode	l3wfmTBL.9	INTEGER	R/W	0 = Normal 1 = Pass

I3veto-TBL (3) group

MIB	OID	SYNTAX	ACCESS	Value/Range
I3vecIntenTBL	I3vectorTBL.1	Aggregate	--	--
I3vecIntenVector	I3vecIntenTBL.1	INTEGER	R/W	-128 to 127
I3vecIntenScale	I3vecIntenTBL.2	INTEGER	R/W	-8 to 7
I3vecGainTBL	I3vectorTBL.1	Aggregate	--	--
I3vecGainVar	I3vecGainTBL.1	INTEGER	R/W	0 = Cal 1 = Val
I3vecGainMag	I3vecGainTBL.2	INTEGER	R/W	0 = X1 1 = X5 2 = IQ-MAG
I3vecGainEavSav	I3vecGainTBL.3	INTEGER	R/W	0 = Remove 1 = Pass
I3vecLineSelectTBL	I3vectorTBL.3	Aggregate	--	--
I3vecLineSelect	I3vecLineSelectTBL.1	INTEGER	R/W	0 = off 1 = on
I3vecLineSelectNumber	I3vecLineSelectTBL.2	INTEGER	R/W	1 to 1125
I3vecLineSelectField	I3vecLineSelectTBL.3	INTEGER	R/W	0 = FIELD1 1 = FIELD2 2 = FRAME
I3vecColorSystemTBL	I3vectorTBL.5	Aggregate	--	--
I3vecColorSystemBar	I3vecColorSystemTBL.1	INTEGER	R/W	0 = 100% 1 = 75%
I3vecColorSystemMatrix	I3vecColorSystemTBL.2	INTEGER	R/W	0 = Component 1 = Composit
I3vecColorSystemSetup	I3vecColorSystemTBL.3	INTEGER	R/W	0 = 0% 1 = 7.5%
I3vecScaleTBL	I3vectorTBL.5	Aggregate	--	--
I3vecScaleColor	I3vecScaleTBL.1	INTEGER	R/W	0 = White 1 = Yellow 2 = Cyan 3 = Green 4 = Magenta 5 = Red 6 = Blue
I3vecScaleIQAXIS	I3vecScaleTBL.2	INTEGER	R/W	0 = off 1 = on

I3pictureTBL (4) group

MIB	OID	SYNTAX	ACCESS	Value/Range
I3picMarkerTBL	I3pictureTBL.1	Aggregate	--	--
I3picMarker43	I3picMarkerTBL.1	INTEGER	R/W	0 = off 1 = on
I3picMarker169	I3picMarkerTBL.2	INTEGER	R/W	0 = off 1 = on
I3picMarkerSafeAction	I3picMarkerTBL.3	INTEGER	R/W	0 = off 1 = on
I3picMarkerSafeTitle	I3picMarkerTBL.4	INTEGER	R/W	0 = off 1 = on
I3picMarkerCenter	I3picMarkerTBL.5	INTEGER	R/W	0 = off 1 = on
I3picLineSelectTBL	I3pictureTBL.2	Aggregate	--	--
I3picLineSelect	I3picLineSelectTBL.1	INTEGER	R/W	0 = off 1 = on
I3picLineSelectNumber	I3picLineSelectTBL.2	INTEGER	R/W	1 to 1125
I3picLineSelectField	I3picLineSelectTBL.3	INTEGER	R/W	0 = FIELD1 1 = FIELD2 2 = FRAME
I3picSize	I3picLineSelectTBL.4	INTEGER	R/W	0 = Fit 1 = X1

I3audioTBL (5) group

MIB	OID	SYNTAX	ACCESS	Value/Range
I3audMode	I3audioTBL.1	INTEGER	R/W	0 = Sound 2 = Lissajou 3 = Mult_liss 4 = Value
I3audSdiTBL	I3audioTBL.2	Aggregate	--	--
I3audSdi1st	I3audSdiTBL.1	INTEGER	R/W	0 = 1 1 = 2 2 = 3 3 = 4
I3audSdi2nd	I3audSdiTBL.2	INTEGER	R/W	0 = 1 1 = 2 2 = 3 3 = 4
I3audSoundTBL	I3audioTBL.3	Aggregate	--	--
I3audSoundAudio	I3audSoundTBL.1	INTEGER	R/W	-8 to 7
I3audSoundScale	I3audSoundTBL.2	INTEGER	R/W	-8 to 7
I3audSurround	I3audSoundTBL.3	INTEGER	R/W	0 = 3-1 1 = 3-2 2 = 3-2-2
I3audSoundLissajou	I3audSoundTBL.4	INTEGER	R/W	0 = X-Y 1 = Matrix
I3audSoundLissal	I3audSoundTBL.5	INTEGER	R/W	0 = CH1 or 5, 9, 13 1 = CH2 or 6, 10, 14 2 = CH3 or 7, 11, 15 3 = CH4 or 8, 12, 16
I3audSoundLissar	I3audSoundTBL.6	INTEGER	R/W	4 = CH1 or 5, 9, 13 5 = CH2 or 6, 10, 14 6 = CH3 or 7, 11, 15 7 = CH4 or 8, 12, 16
I3audSoundGain	I3audSoundTBL.7	INTEGER	R/W	0 = X' 1 = X ² 2 = X'0 3 = X0.5 8 = All to
I3audMeterTBL	I3audioTBL.4	Aggregate	--	--
I3audMeterRef	I3audMeterTBL.1	INTEGER	R/W	0 = -20dB 1 = -18dB 2 = -12dB

LV 5750 Addendum Instruction Manual

MIB	OID	SYNTAX	ACCESS	Value/Range
I3audMeterRange	I3audMeterTBL.2	INTEGER	R/W	0 = Peak60dB 1 = Peak90dB 2 = Average
I3audMeterScale	I3audMeterTBL.3	INTEGER	R/W	0 = Type A 1 = Type B
I3audMeterPeakHold	I3audMeterTBL.4	OctetString	R/W	0 = 0.5 1 = 1.0 2 = 2.0 3 = 3.0 4 = 4.0 5 = 5.0 6 = 6.0 7 = 7.0 8 = 8.0 9 = 9.0 10 = Hold
I3audPhonesTBL	I3audioTBL.5	Aggregate	--	--
I3audPhonesOut	I3audPhonesTBL.1	INTEGER	R/W	0 = on 1 = off
I3audPhonesVolume	I3audPhonesTBL.2	INTEGER	R/W	0 to 128
I3audPhonesL	I3audPhonesTBL.3	INTEGER	R/W	0 = CH1 1 = CH2 2 = CH3 3 = CH4 4 = CH5 5 = CH6 6 = CH7 7 = CH8
I3audPhonesR	I3audPhonesTBL.4	INTEGER	R/W	0 = CH1 1 = CH2 2 = CH3 3 = CH4 4 = CH5 5 = CH6 6 = CH7 7 = CH8
I3audChMapTBL	I3audioTBL.6	Aggregate	--	--

MIB	OID	SYNTAX	ACCESS	Value/Range
I3audChMapL	I3audChMapTBL.1	INTEGER	R/W	0 = CH1, 5, 9, 13 1 = CH2, 6, 10, 14 2 = CH3, 7, 11, 15 3 = CH4, 8, 12, 16 4 = CH1, 5, 9, 13 5 = CH2, 6, 10, 14 6 = CH3, 7, 11, 15 7 = CH4, 8, 12, 16
I3audChMapR	I3audChMapTBL.2	INTEGER	R/W	0 = CH1, 5, 9, 13 1 = CH2, 6, 10, 14 2 = CH3, 7, 11, 15 3 = CH4, 8, 12, 16 4 = CH1, 5, 9, 13 5 = CH2, 6, 10, 14 6 = CH3, 7, 11, 15 7 = CH4, 8, 12, 16
I3audChMapSL	I3audChMapTBL.3	INTEGER	R/W	0 = CH1, 5, 9, 13 1 = CH2, 6, 10, 14 2 = CH3, 7, 11, 15 3 = CH4, 8, 12, 16 4 = CH1, 5, 9, 13 5 = CH2, 6, 10, 14 6 = CH3, 7, 11, 15 7 = CH4, 8, 12, 16
I3audChMapSR	I3audChMapTBL.4	INTEGER	R/W	0 = CH1, 5, 9, 13 1 = CH2, 6, 10, 14 2 = CH3, 7, 11, 15 3 = CH4, 8, 12, 16 4 = CH1, 5, 9, 13 5 = CH2, 6, 10, 14 6 = CH3, 7, 11, 15 7 = CH4, 8, 12, 16
I3audChMapC	I3audChMapTBL.5	INTEGER	R/W	0 = C-1, 5, 9, 13 1 = C-2, 6, 10, 14 2 = CH3, 7, 11, 15 3 = CH4, 8, 12, 16 4 = CH1, 5, 9, 13 5 = CH2, 6, 10, 14 6 = CH3, 7, 11, 15 7 = CH4, 8, 12, 16

MIB	OID	SYNTAX	ACCESS	Value/Range
I3audChMapLFE	I3audChMapTBL.6	INTEGER	R/W	0 = CH1, 5, 9, 13 1 = CH2, 6, 10, 14 2 = CH3, 7, 11, 15 3 = CH4, 8, 12, 16 4 = CH1, 5, 9, 13 5 = CH2, 6, 10, 14 6 = CH3, 7, 11, 15 7 = CH4, 8, 12, 16
I3audChMapRL	I3audChMapTBL.7	INTEGER	R/W	0 = CH1, 5, 9, 13 1 = CH2, 6, 10, 14 2 = CH3, 7, 11, 15 3 = CH4, 8, 12, 16 4 = CH1, 5, 9, 13 5 = CH2, 6, 10, 14 6 = CH3, 7, 11, 15 7 = CH4, 8, 12, 16
I3audChMapRR	I3audChMapTBL.8	INTEGER	R/W	0 = CH1, 5, 9, 13 1 = CH2, 6, 10, 14 2 = CH3, 7, 11, 15 3 = CH4, 8, 12, 16 4 = CH1, 5, 9, 13 5 = CH2, 6, 10, 14 6 = CH3, 7, 11, 15 7 = CH4, 8, 12, 16

I3multiTBL (6) group

MIB	OID	SYNTAX	ACCESS	Value/Range
I3multMode	I3multiTBL.1	INTEGER	R/W	0 = 4\$SCREEN 1 = WFM-VEC 2 = WFM-PIC 3 = WFM-AUD 4 = WFM-LVL
I3multUpper	I3multiTBL.2	INTEGER	R/W	0 = VECTOR 1 = AUDIO
I3multLower	I3multiTBL.3	INTEGER	R/W	0 = Status 1 = AUD-LVL

I3statusTBL (7) group

MIB	OID	SYNTAX	ACCESS	Value/Range
I3statusTBL	I3statusTBL.1	Aggregate	--	--
I3staLogLog	I3staLogTBL.1	INTEGER	R/W	0 = Start 1 = Stop
I3staLogClear	I3staLogTBL.2	INTEGER	R/WO	0 = Clear
I3staLogMode	I3staLogTBL.3	INTEGER	R/W	0 = Over WR 1 = Stop
I3staDumpTBL	I3statusTBL.2	Aggregate	--	--
I3staDumpMode	I3staDumpTBL.1	INTEGER	R/W	0 = Run 1 = Hold
I3staDumpDisplay	I3staDumpTBL.2	INTEGER	R/W	0 = Serial 1 = Compo 2 = Binary
I3staDumpLineNumber	I3staDumpTBL.3	INTEGER	R/W	1 to 1125
I3staDumpSample	I3staDumpTBL.4	INTEGER	R/W	0 to 2749 Note: The sample number is even when the format is 525i or 625i. If an odd number is specified, it is set to the previous even number. Example: 123 becomes 122.
I3staDumpEav	I3staDumpTBL.5	INTEGER	R/WO	0 = Dump EAV
I3staDumpSav	I3staDumpTBL.6	INTEGER	R/WO	0 = Dump SAV
I3staDumpFD	I3staDumpTBL.7	INTEGER	R/WO	0 = Line 1 = Sample
I3staAudioTBL	I3statusTBL.3	Aggregate	--	--
I3staAudioChSEL	I3staAudioTBL.1	INTEGER	R/W	0 = CH1, 5, 9, 13 1 = CH2, 6, 10, 14 2 = CH3, 7, 11, 15 3 = CH4, 8, 12, 16 4 = CH1, 5, 9, 13 5 = CH2, 6, 10, 14 6 = CH3, 7, 11, 15 7 = CH4, 8, 12, 16
I3staErrTBL	I3statusTBL.4	Aggregate	--	--
I3staRemoteErr	I3staErrTBL.1	INTEGER	R/W	0 = off 1 = on
I3staErrCountRate	I3staErrTBL.2	INTEGER	R/W	0 = V-Rate 1 = 1/Sec
I3staErrDetectTBL	I3staErrTBL.3	Aggregate	--	--

LV 5750 Addendum Instruction Manual

MIB	OID	SYNTAX	ACCESS	Value/Range
l3staErrDetectTrs	l3staErrDetectTBL.1	INTEGER	R/W	0 = off 1 = on
l3staErrDetectLine	l3staErrDetectTBL.2	INTEGER	R/W	0 = off 1 = on
l3staErrDetectCRC	l3staErrDetectTBL.3	INTEGER	R/W	0 = off 1 = on
l3staErrDetectEDH	l3staErrDetectTBL.4	INTEGER	R/W	0 = off 1 = on
l3staErrDetectParity	l3staErrDetectTBL.6	INTEGER	R/W	0 = off 1 = on
l3staErrDetectCheckSum	l3staErrDetectTBL.7	INTEGER	R/W	0 = off 1 = on
l3staErrDetectGamut	l3staErrDetectTBL.9	INTEGER	R/W	0 = off 1 = on
l3staErrDetectCGamut	l3staErrDetectTBL.10	INTEGER	R/W	0 = off 1 = on
l3staErrDetectBCH	l3staErrDetectTBL.11	INTEGER	R/W	0 = off 1 = on
l3staErrDetectCable	l3staErrDetectTBL.14	INTEGER	R/W	0 = off 1 = on
l3staErrLevTBL	l3staErrTBL.4	Aggregate	--	--
l3staErrLevGamutTBL	l3staErrLevTBL.1	Aggregate	--	--
l3staErrLevGamutUpper	l3staErrLevGamutTBL.1	OctetString	R/W	90.8 to 109.4
l3staErrLevGamutLower	l3staErrLevGamutTBL.2	OctetString	R/W	-7.2 to 6.1
l3staErrLevCGamutTBL	l3staErrLevTBL.2	Aggregate	--	--
l3staErrLevCGamutUpper	l3staErrLevCGamutTBL.1	OctetString	R/W	90.0 to 135.0
l3staErrLevCGamutLower	l3staErrLevCGamutTBL.2	OctetString	R/W	-40.0 to -20.0
l3staErrLevCableTBL	l3staErrLevTBL.3	Aggregate	--	--
l3staErrLevCableHDLen	l3staErrLevCableTBL.1	INTEGER	R/W	5 to 130
l3staErrLevCableHDWar	l3staErrLevCableTBL.2	INTEGER	R/W	5 to 130
l3staErrLevCableSDLen	l3staErrLevCableTBL.3	INTEGER	R/W	50 to 300
l3staErrLevCableSDWar	l3staErrLevCableTBL.4	INTEGER	R/W	50 to 300
l3staErrDisplay	l3staErrTBL.5	INTEGER	R/W	0 = Refresh 1 = Hold
l3staCableTBL	l3statusTBL.5	Aggregate	--	--
l3staCableHDSdi	l3staCableTBL.1	INTEGER	R/W	0 = LS-5CFB 1 = 1694A 2 = L-7CHD

MIB	OID	SYNTAX	ACCESS	Value/Range
I3staCableSDSdi	I3staCableTBL.2	INTEGER	R/W	0 = L-5C2V 1 = 8281 2 = 1505A
I3staReset	I3statusTBL.6	INTEGER	R/WO	0 = RESET

I3captureTBL (8) group

MIB	OID	SYNTAX	ACCESS	Value/Range
I3capDisplay	I3captureTBL.1	INTEGER	R/W	0 = Real 1 = Hold 2 = Both
I3capFileSelect	I3captureTBL.2	INTEGER	R/W	0 = Bmp Bsx 1 = Bmp 2 = Bsx

I3filesTBL (9) group

MIB	OID	SYNTAX	ACCESS	Value/Range
I3filMakeTBL	I3filesTBL.1	Aggregate	--	--
I3filMakeStatus	I3filMakeTBL.1	INTEGER	R/WO	0 = Make Status
I3filMakeLog	I3filMakeTBL.2	INTEGER	R/WO	0 = Make Log
I3filMakeDump	I3filMakeTBL.3	INTEGER	R/WO	0 = Make Dump
I3filMakeCapture	I3filMakeTBL.4	INTEGER	R/WO	0 = Make Capture
I3filRecall	I3filesTBL.2	INTEGER	R/W	1 to 30

LV 5750 Addendum Instruction Manual

13systemTBL (10) group

MIB	OID	SYNTAX	ACCESS	Value/Range
13 sysFormatTBL	13 systemTBL.1	Aggregate	--	--
13 sysFormatMode	13 sysFormatTBL.1	INTEGER	R/W	0 = Auto 1 = Manual
13 sysFormatFormat	13 sysFormatTBL.2	INTEGER	R/W	0 = 1080I/60 1 = 1080I/59.94 2 = 1080I/50 3 = 1080PSF/30 4 = 1080PSF/29.97 5 = 1080PSF/25 6 = 1080P/30 7 = 1080P/29.97 8 = 1080P/25 9 = 1080SF/24 10 = 1080PSF/24 11 = 1080P/23.98 12 = 1080PSF/23.98 13 = 1035I/60 14 = 1035I/59.94 15 = 720P/60 16 = 720P/59.94 17 = 720P/50 18 = 720P/30 19 = 720P/29.97 20 = 720P/25 21 = 720P/24 22 = 720P/23.98 23 = 525I/59.94 24 = 625I/50
13 sysFormatCompositeFormat	13 sysFormatTBL.4	INTEGER	R/W	0 = Auto 1 = NTSC 2 = PAL
13 sysFormatIPSF	13 sysFormatTBL.5	INTEGER	R/W	0 = Interlac 1 = Seg.Fram
13 sysDispTBL	13 systemTBL.2	Aggregate	--	--
13 sysDispInfoTBL	13 sysDispTBL.1	Aggregate	--	--
13 sysDispInfoFormat	13 sysDispInfoTBL.1	INTEGER	R/W	0 = off 1 = on
13 sysDispInfoTime	13 sysDispInfoTBL.2	INTEGER	R/W	0 = Real 1 = Timecode 2 = off

MIB	OID	SYNTAX	ACCESS	Value/Range
13 sysDisplInfoDate	13 sysDisplInfoTBL.3	INTEGER	R/W	0 = Y-M-D 1 = M-D-Y 2 = D-M-Y 3 = off
13 sysDisplInfoColor	13 sysDisplInfoTBL.4	INTEGER	R/W	0 = off 1 = on
13 sysVersionTBL	13 systemTBL.3	Aggregate	--	--
13 sysDate	13 systemTBL.4	OctetString	R/W	yyyy/mm/dd HH:MM:SS
13 sysSCutShortCutKey	13 systemTBL.5	INTEGER	R/W	0 = KeyLED 1 = DirectK
13 sysInit	13 systemTBL.6	INTEGER	R/WO	90 = Initial
13 sysSoftwareVersion	13 sysVersionTBL.1	INTEGER	R/O	ver information

13trapTBL (11) group

MIB	OID	SYNTAX	ACCESS	Value/Range
13trapStrTBL	13 trapTBL.1	Aggregate	--	-- (Variable Binding List)
13 trapManagerIp	13 trapTBL.2	IpAddress	R/W	IP address of destination Manager of Trap
13 trapID	13 trapTBL.3	INTEGER	R/O	0

7.5 Enterprise Trap

This section describes the enterprise traps of the LV 5750.

7.5.1 Trap Community Name

The trap community name is fixed as follows:

Trap Community: LDRUser

7.5.2 Setting the IP Address of the SNMP Manager

Assign the IP address of the SNMP manager to the following MIB object.

"1.3.6.1.4.1.leader(20111).lv5750(1).lv5750_st(1).trapTBL(11).trapManagerIp(2).0"

7.5.3 Specific Traps

Description	Specific Trap Type
Fan stop detection	1
Fan restart detection	2
NO SIGNAL	3
FORMAT ERROR	4
TRS error detection	5
Line number error detection	6
CRC error detection (LUMA)	7
CRC error detection (CHROMA)	8
Checksum error detection	9
BCH error detection	10
EDH error detection	11
Parity error detection	13
Equivalent cable length meter error detection	19
Equivalent cable length meter warning detection	20
Gamut error detection	23
Composite gamut error detection	24
No error (at error recovery and startup)	37

Error detection specifications:

The error is detected at V SYNC intervals, but errors are transmitted at 1-second intervals.

Errors that occur over the 1-second interval are consolidated.

If an error that was transmitted 1 second earlier is detected again, it is not transmitted the next time.

7.5.4 Description of the Variable Binding List

index 1:

OID: leader(20111).LV5750(1).lv5750ST1(1).trapTBL(11).trapStrTBL(1).1.0

Syntax: Counter

Range: 1 to 4294967295 (overflow occurs if this range is exceeded)

Description: The total number of enterprise traps sent after starting up.

index 2:

OID: leader(20111).LV5750(1).lv5750ST1(1).trapTBL(11).trapStrTBL(1).2.0

Syntax: Octet String

Range: Up to 40 characters

Description: Date/Time when the error occurred and line information
YYYY/MM/DD hh:mm:ss ,mod,sdi,ref

YYYY = Year

MM = Month

DD = Day

hh = Hour

mm = Minute

ss = Second

mod = Module Number (1 or 2)

sdi = SDI INPUT (A or B)

ref = Reference (I (Internal) or E (External))

Example: 2004/07/15 11:30:11 ,1,A,I

index 3:

OID: leader(20111).LV5750(1).lv5750ST1(1).trapTBL(11).trapStrTBL(1).3.0

Syntax: Octet String

Range: Up to 40 characters

Description: Format information

Example "1080sF/30 ,"

Format information for traps

Syntax	Format
1080sF/30	1080sF/30
1080sF/29.97	1080sF/29.97
1080sF/25	1080sF/25
1080p/30	1080p/30
1080i/60	1080i/60
1080p/25	1080p/25
1080i/50	1080i/50
1080p/24	1080p/24
1080sF/24	1080sF/24
720p/60	720p/60
720p/50	720p/50
720p/30	720p/30
720p/25	720p/25
720p/24	720p/24
1080p/29.97	1080p/29.97
1080i/59.94	1080i/59.94
1080p/24.97	1080p/24.97
1080i/50	1080i/50
1080p/23.98	1080p/23.98
1080sF/23.98	1080sF/23.98
720p/59.94	720p/59.94
720p/50	720p/50
720p/29.97	720p/29.97
720p/25	720p/25
720p/23.98	720p/23.98
525i/59.94	525i/59.94
625i/50	625i/50
FORMAT_ERROR	FORMAT ERROR
NO_SIGNAL	NO SIGNAL

index 4:

OID: leader(20111).LV5750(1).lv5750ST1(1).trapTBL(1).trapStrTBL(1).4.0
 Syntax: Octet String
 Range: Up to 40 characters
 Description: Error information
 Example "TRS_ERR"

Error information for TRAPs

Syntax	Description
TRS_ERR	TRS error detection
LINE_ERR	Line number error detection
CRC_L_ERR	CRC error detection (LUMA)
CRC_C_ERR	CRC error detection (CHROMA)
CHECKSUM_ERR	Checksum error detection
BCH_ERR	BCH error detection
EDH_ERR	EDH error detection
GAMUT_ERR	Gamut error detection
COMP_GAMUT_ERR	Composite gamut error detection
PARITY_ERR	Parity error detection
CABLE_ERR	Equivalent cable length meter error detection
CABLE_WAR	Equivalent cable length meter warning detection
FAN_STOP	Fan stop detection
FAN_RESTART	Fan restart detection



LEADER ELECTRONICS CORP.

2-6-33 Tsunashima-Higashi, Kohoku-ku, Yokohama 223-8505, Japan
PHONE: 81-45-541-2123 FAX: 81-45-541-2823 <http://www.leader.co.jp>

LEADER INSTRUMENTS CORP.

6484 Commerce Drive, Cypress, California 90630 U.S.A.
PHONE: 1-714-527-9300 FAX: 1-714-527-7490 <http://www.LeaderUSA.com>

LEADER INSTRUMENTS (H.K.) LTD.

Room 303-304 New East Ocean Centre, 9 Science Museum Road,
Tsimshatsui East, Kowloon, HONG KONG
PHONE: 852-2721-2503 FAX: 852-2723-7573